

RED
HAWK *Linux*[®] *User's Guide*

Copyright 2009 by Concurrent Computer Corporation. All rights reserved. This publication or any part thereof is intended for use with Concurrent products by Concurrent personnel, customers, and end-users. It may not be reproduced in any form without the written permission of the publisher.

The information contained in this document is believed to be correct at the time of publication. It is subject to change without notice. Concurrent makes no warranties, expressed or implied, concerning the information contained in this document.

To report an error or comment on a specific portion of the manual, photocopy the page in question and mark the correction or comment on the copy. Mail the copy (and any additional comments) to Concurrent Computer Corporation, 2881 Gateway Drive, Pompano Beach, Florida, 33069. Mark the envelope “**Attention: Publications Department.**” This publication may not be reproduced for any other reason in any form without written permission of the publisher.

Concurrent Computer Corporation and its logo are registered trademarks of Concurrent Computer Corporation. All other Concurrent product names are trademarks of Concurrent while all other product names are trademarks or registered trademarks of their respective owners. Linux® is used pursuant to a sublicense from the Linux Mark Institute.

Printed in U. S. A.

Revision History:

<u>Date</u>	<u>Level</u>	<u>Effective With</u>
August 2002	000	RedHawk Linux Release 1.1
September 2002	100	RedHawk Linux Release 1.1
December 2002	200	RedHawk Linux Release 1.2
April 2003	300	RedHawk Linux Release 1.3, 1.4
December 2003	400	RedHawk Linux Release 2.0
March 2004	410	RedHawk Linux Release 2.1
July 2004	420	RedHawk Linux Release 2.2
May 2005	430	RedHawk Linux Release 2.3
March 2006	500	RedHawk Linux Release 4.1
May 2006	510	RedHawk Linux Release 4.1
May 2007	520	RedHawk Linux Release 4.2
April 2008	600	RedHawk Linux Release 5.1
June 2008	610	RedHawk Linux Release 5.1
October 2008	620	RedHawk Linux Release 5.2
December 2009	630	RedHawk Linux Release 5.4

Scope of Manual

This manual consists of three parts. The information in Part 1 is directed towards real-time users. Part 2 is directed towards system administrators. Part 3 consists of backmatter: appendixes, glossary and index. An overview of the contents of the manual follows.

Structure of Manual

This guide consists of the following sections:

Part 1 - Real-Time User

- Chapter 1, *Introduction*, provides an introduction to the RedHawk Linux operating system and an overview of the real-time features included.
- Chapter 2, *Real-Time Performance*, discusses issues involved with achieving real-time performance including interrupt response, process dispatch latency and deterministic program execution. The shielded CPU model is described.
- Chapter 3, *Real-Time Interprocess Communication*, discusses procedures for using the POSIX[®] and System V message-passing and shared memory facilities.
- Chapter 4, *Process Scheduling*, provides an overview of process scheduling and describes POSIX scheduling policies and priorities.
- Chapter 5, *Interprocess Synchronization*, describes the interfaces provided by RedHawk Linux for cooperating processes to synchronize access to shared resources. Included are: POSIX counting semaphores, System V semaphores, rescheduling control tools and condition synchronization tools.
- Chapter 6, *Programmable Clocks and Timers*, provides an overview of some of the RCIM and POSIX timing facilities available under RedHawk Linux.
- Chapter 7, *System Clocks and Timers*, describes system timekeeping and the per-CPU local timer.
- Chapter 8, *File Systems and Disk I/O*, explains the xfs journaling file system and procedures for performing direct disk I/O on the RedHawk Linux operating system.
- Chapter 9, *Memory Mapping*, describes the methods provided by RedHawk Linux for a process to access the contents of another process' address space.
- Chapter 10, *Non-Uniform Memory Access (NUMA)*, describes the NUMA support available on certain systems.

Part 2 - Administrator

- Chapter 11, *Configuring and Building the Kernel*, provides information on how to configure and build a RedHawk Linux kernel.

- Chapter 12, *Kernel Debugging*, provides guidelines for saving, restoring and analyzing the kernel memory image using **kdump** and **crash** and basic use of the **kdb** kernel debugger.
- Chapter 13, *Pluggable Authentication Modules (PAM)*, describes the PAM authentication capabilities of RedHawk Linux.
- Chapter 14, *Device Drivers*, describes RedHawk functionality and real-time issues involved with writing device drivers.
- Chapter 15, *PCI-to-VME Support*, describes RedHawk's support for a PCI-to-VME bridge.

Part 3 - Common Material

- Appendix A, *Example Message Queue Programs*, contains example programs illustrating the POSIX and System V message queue facilities.
- Appendix B, *Kernel Tunables for Real-time Features*, contains a listing of the kernel tunables that control unique features in RedHawk Linux and their default values in pre-built kernels.
- Appendix C, *Capabilities*, lists the capabilities included in RedHawk Linux and the permissions provided by each.
- Appendix D, *Kernel Trace Events*, lists pre-defined kernel trace points and methods for defining and logging custom events within kernel modules.
- Appendix E, *Migrating 32-bit Code to 64-bit Code*, provides information needed to migrate 32-bit code to 64-bit processing on an x86_64 processor.
- Appendix F, *Kernel-level Daemons on Shielded CPUs*, describes how kernel-level daemons execute on shielded CPUs and provides methods for improving performance.
- Appendix G, *Cross Processor Interrupts on Shielded CPUs*, describes how cross-processor interrupts execute on shielded CPUs and provides methods for improving performance.
- Appendix H, *Serial Console Setup*, provides instructions for configuring a serial console.
- Appendix I, *Boot Command Line Parameters*, discusses the boot parameters unique to RedHawk.
- The *Glossary* provides definitions for terms used throughout this Guide.
- The *Index* contains an alphabetical reference to key terms and concepts and the pages where they occur in the text.

Syntax Notation

The following notation is used throughout this manual:

italic Books, reference cards, and items that the user must specify appear in *italic* type. Special terms may also appear in *italic*.

list bold	User input appears in list bold type and must be entered exactly as shown. Names of directories, files, commands, options and man page references also appear in list bold type.
list	Operating system and program output such as prompts, messages and listings of files and programs appears in list type.
[]	Brackets enclose command options and arguments that are optional. You do not type the brackets if you choose to specify these options or arguments.
hypertext links	When viewing this document online, clicking on chapter, section, figure, table and page number references will display the corresponding text. Clicking on Internet URLs provided in blue type will launch your web browser and display the web site. Clicking on publication names and numbers in red type will display the corresponding manual PDF, if accessible.

Related Publications

The following table lists RedHawk Linux documentation. Click on the red entry to display the document PDF (optional product documentation is available for viewing only if the optional product has been installed). These documents are also available by clicking on the “Documents” icon on the desktop and from Concurrent’s web site at www.ccur.com.

RedHawk Linux Operating System Documentation	Pub. Number
<i>RedHawk Linux Online Documentation Roadmap</i>	0898002
<i>RedHawk Linux Release Notes</i>	0898003
<i>RedHawk Linux User’s Guide</i>	0898004
<i>Real-Time Clock & Interrupt Module (RCIM) User’s Guide</i>	0898007
<i>iHawk Optimization Guide</i>	0898011
<i>RedHawk Linux FAQ</i>	N/A
Optional RedHawk Product Documentation	
<i>RedHawk Linux Frequency-Based Scheduler (FBS) User’s Guide</i>	0898005

Contents

Preface	iii
----------------------	-----

Chapter 1 Introduction

Overview	1-1
RedHawk Linux Kernels	1-3
System Updates	1-4
Real-Time Features	1-4
Processor Shielding	1-4
Processor Affinity	1-4
User-level Preemption Control	1-5
Fast Block/Wake Services	1-5
RCIM Driver	1-5
Frequency-Based Scheduler	1-5
/proc Modifications	1-6
Kernel Trace Facility	1-6
ptrace Extensions	1-6
Kernel Preemption	1-6
Real-Time Scheduler	1-7
Low Latency Enhancements	1-7
Priority Inheritance	1-7
High Resolution Process Accounting	1-7
Capabilities Support	1-7
Kernel Debuggers	1-8
Kernel Core Dumps/Crash Analysis	1-8
User-level Spin Locks	1-8
usermap and /proc mmap	1-8
Hyper-threading	1-8
XFS Journaling File System	1-9
POSIX Real-Time Extensions	1-9
User Priority Scheduling	1-9
Memory Resident Processes	1-9
Memory Mapping and Data Sharing	1-10
Process Synchronization	1-10
Asynchronous Input/Output	1-10
Synchronized Input/Output	1-10
Real-Time Signal Behavior	1-11
Clocks and Timers	1-11
Message Queues	1-11

Chapter 2 Real-Time Performance

Overview of the Shielded CPU Model	2-1
Overview of Determinism	2-2
Process Dispatch Latency	2-2
Effect of Disabling Interrupts	2-4
Effect of Interrupts	2-5
Effect of Disabling Preemption	2-8

Effect of Open Source Device Drivers	2-9
How Shielding Improves Real-Time Performance.	2-9
Shielding From Background Processes	2-9
Shielding From Interrupts	2-10
Shielding From Local Interrupt.	2-11
Interfaces to CPU Shielding	2-12
Shield Command	2-12
Shield Command Examples	2-13
Exit Status.	2-13
Shield Command Advanced Features	2-14
/proc Interface to CPU Shielding.	2-14
Assigning Processes to CPUs	2-14
Multiprocessor Control Using mpadvise	2-15
Assigning CPU Affinity to init.	2-17
Example of Setting Up a Shielded CPU	2-17
Procedures for Increasing Determinism	2-20
Locking Pages in Memory.	2-20
Setting the Program Priority	2-20
Setting the Priority of Deferred Interrupt Processing	2-21
Waking Another Process	2-21
Avoiding Cache Thrashing	2-22
Reserving Physical Memory	2-22
Binding to NUMA Nodes	2-27
I/O Throughput on Quad Opteron Systems.	2-27
Understanding Hyper-threading	2-28
System Configuration.	2-30
Recommended CPU Configurations	2-30
Avoiding a Low Memory State	2-34
Known Issues with Linux Determinism	2-34

Chapter 3 Real-Time Interprocess Communication

Overview.	3-1
POSIX Message Queues.	3-2
System V Messages	3-3
Using Messages.	3-4
The msgget System Call	3-7
The msgctl System Call.	3-9
The msgsnd and msgrcv System Calls	3-10
Sending a Message.	3-10
Receiving a Message	3-11
POSIX Shared Memory	3-12
Using the shm_open Routine.	3-13
Using the shm_unlink Routine	3-15
System V Shared Memory	3-15
Using Shared Memory.	3-16
The shmget System Call	3-19
The shmctl System Call.	3-21
Binding a Shared Memory Segment to I/O Space.	3-22
Using shmget	3-22
Using shmbind	3-23
The shmat and shmdt System Calls.	3-23
Attaching a Shared Memory Segment	3-24
Detaching Shared Memory Segments	3-24

Shared Memory Utilities	3-25
The shmdefine Utility	3-25
The shmconfig Command	3-25

Chapter 4 Process Scheduling

Overview	4-1
How the Process Scheduler Works	4-2
Scheduling Policies	4-3
First-In-First-Out Scheduling (SCHED_FIFO)	4-3
Round-Robin Scheduling (SCHED_RR)	4-4
Time-Sharing Scheduling (SCHED_OTHER)	4-4
Procedures for Enhanced Performance	4-4
How to Set Priorities	4-4
Interrupt Routines	4-5
SCHED_FIFO vs SCHED_RR	4-5
Fixed Priority Processes Locking Up a CPU	4-5
Memory Locking	4-6
CPU Affinity and Shielded Processors	4-6
Process Scheduling Interfaces	4-6
POSIX Scheduling Routines	4-6
The sched_setscheduler Routine	4-7
The sched_getscheduler Routine	4-8
The sched_setparam Routine	4-9
The sched_getparam Routine	4-10
The sched_yield Routine	4-10
The sched_get_priority_min Routine	4-11
The sched_get_priority_max Routine	4-11
The sched_rr_get_interval Routine	4-12
The run Command	4-13

Chapter 5 Interprocess Synchronization

Understanding Interprocess Synchronization	5-1
Rescheduling Control	5-3
Understanding Rescheduling Variables	5-3
Using resched_cntl System Call	5-4
Using the Rescheduling Control Macros	5-5
resched_lock	5-5
resched_unlock	5-6
resched_nlocks	5-6
Applying Rescheduling Control Tools	5-7
Busy-Wait Mutual Exclusion	5-7
Understanding the spin_mutex Variable	5-7
Using the spin_mutex Interfaces	5-8
Applying spin_mutex Tools	5-9
Understanding the noproempt_spin_mutex Variable	5-10
Using the noproempt_spin_mutex Interfaces	5-10
POSIX Counting Semaphores	5-12
Overview	5-12
Interfaces	5-13
The sem_init Routine	5-14
The sem_destroy Routine	5-15
The sem_open Routine	5-16
The sem_close Routine	5-17

The sem_unlink Routine	5-18
The sem_wait Routine	5-19
The sem_timedwait Routine.	5-19
The sem_trywait Routine	5-20
The sem_post Routine	5-20
The sem_getvalue Routine.	5-21
Extensions to POSIX Mutexes	5-21
Robust Mutexes	5-22
Priority Inheritance	5-23
User Interface	5-23
pthread_mutex_consistent_np	5-24
pthread_mutex_getunlock_np	5-24
pthread_mutex_setconsistency_np.	5-24
pthread_mutex_setunlock_np.	5-25
pthread_mutexattr_getfast_np	5-25
pthread_mutexattr_getprotocol.	5-25
pthread_mutexattr_getrobust_np	5-26
pthread_mutexattr_getunlock_np.	5-26
pthread_mutexattr_setfast_np.	5-26
pthread_mutexattr_setprotocol.	5-27
pthread_mutexattr_setrobust_np	5-27
pthread_mutexattr_setunlock_np	5-27
Compiling Programs with POSIX Mutexes	5-27
System V Semaphores	5-28
Overview	5-28
Using System V Semaphores	5-29
The semget System Call	5-31
The semctl System Call.	5-34
The semop System Call.	5-36
Condition Synchronization	5-37
The postwait System Call	5-37
The Server System Calls	5-39
server_block	5-39
server_wake1	5-40
server_wakevec	5-41
Applying Condition Synchronization Tools	5-42

Chapter 6 Programmable Clocks and Timers

Understanding Clocks and Timers	6-1
RCIM Clocks and Timers	6-1
POSIX Clocks and Timers.	6-2
Understanding the POSIX Time Structures	6-3
Using the POSIX Clock Routines.	6-4
Using the clock_settime Routine.	6-4
Using the clock_gettime Routine	6-5
Using the clock_getres Routine.	6-5
Using the POSIX Timer Routines.	6-6
Using the timer_create Routine.	6-6
Using the timer_delete Routine	6-8
Using the timer_settime Routine	6-8
Using the timer_gettime Routine.	6-9
Using the timer_getoverrun Routine	6-10
Using the POSIX Sleep Routines	6-11

Using the nanosleep Routine	6-11
Using the clock_nanosleep Routine	6-12

Chapter 7 System Clocks and Timers

System Timekeeping	7-1
Local Timer	7-1
Functionality	7-2
CPU Accounting	7-2
Process Execution Time Quanta and Limits	7-3
Interval Timer Decrementing	7-3
System Profiling	7-3
CPU Load Balancing	7-3
CPU Rescheduling	7-4
POSIX Timers	7-4
RCU Processing	7-4
Miscellaneous	7-4
Disabling the Local Timer	7-4

Chapter 8 File Systems and Disk I/O

Journaling File System	8-1
Creating an XFS File System	8-2
Mounting an XFS File System	8-2
Data Management API (DMAPI)	8-2
Direct Disk I/O	8-3

Chapter 9 Memory Mapping

Establishing Mappings to a Target Process' Address Space	9-1
Using mmap(2)	9-1
Using usermap(3)	9-3
Considerations	9-4
Kernel Configuration Parameters	9-4

Chapter 10 Non-Uniform Memory Access (NUMA)

Overview	10-1
Memory Policies	10-2
NUMA User Interface	10-3
Memory-shielded Nodes	10-3
Memory-shielding and Preallocated Graphics Pages	10-5
NUMA Support for Processes using run(1)	10-7
NUMA Support for Shared Memory Areas using shmconfig(1)	10-9
System Calls	10-11
Library Functions	10-11
Informational Files and Utilities	10-11
Node Statistics	10-11
Node IDs for Mapped Pages	10-12
NUMA Hit/Miss Statistics Using numastat	10-13
kdb Support	10-13
Performance Guidelines	10-14
Task-Wide NUMA Mempolicy	10-14
Shared Memory Segments	10-14

Configuration	10-15
---------------------	-------

Chapter 11 Configuring and Building the Kernel

Introduction.....	11-1
Configuring a Kernel Using ccur-config	11-2
Building a Kernel	11-4
Building Driver Modules	11-5
Example—Building a Dynamic Loadable Module in a Pre-built RedHawk Kernel	11-6
Additional Information	11-7

Chapter 12 Kernel Debugging

Overview.....	12-1
Taking and Analyzing a System Crash	12-1
Activating kdump	12-1
How a Crash Dump is Created	12-2
Installation/Configuration Details	12-3
kdump Options Defined in the Configuration File	12-3
kdump Command Line Interface.....	12-4
Using crash to Analyze the Dump.....	12-5
Analyzing a Dump File	12-5
Analyzing a Live System	12-7
Getting Help	12-7
Kernel Debuggers	12-8
kdb	12-8
NMI Interrupts	12-8
NMI Button	12-9

Chapter 13 Pluggable Authentication Modules (PAM)

Introduction.....	13-1
PAM Modules	13-1
Services.....	13-2
Role-Based Access Control	13-2
Examples	13-3
Defining Capabilities	13-3
Examples	13-4
Implementation Details.....	13-5

Chapter 14 Device Drivers

Understanding Device Driver Types.....	14-1
Developing User-level Device Drivers.....	14-1
Accessing PCI Resources	14-1
PCI BAR Interfaces	14-2
Kernel Skeleton Driver	14-6
Understanding the Sample Driver Functionality	14-6
Testing the Driver.....	14-9
Developing Kernel-level Device Drivers	14-11
Building Driver Modules.....	14-11
Kernel Virtual Address Space	14-11
Real-Time Performance Issues	14-11

Interrupt Routines	14-11
Deferred Interrupt Functions (Bottom Halves)	14-12
Multi-threading Issues	14-14
The Big Kernel Lock (BKL) and ioct1	14-14
Userspace I/O Drivers (UIO)	14-15
Analyzing Performance	14-16

Chapter 15 PCI-to-VME Support

Overview	15-1
Documentation	15-2
Installing the Hardware	15-2
Unpacking	15-2
Configuring the Adapter Cards	15-3
Installing the PCI Adapter Card	15-4
Installing the VMEbus Adapter Card	15-4
Connecting the Adapter Cable	15-4
Installing the Software	15-5
Configuration	15-6
The btp Module	15-6
Device Files and Module Parameter Specifications	15-6
VMEbus Mappings	15-7
User Interface	15-7
API Functions	15-8
Bind Buffer Implementation	15-9
bt_get_info BT_INFO_KMALLOC_BUF	15-9
bt_set_info BT_INFO_KMALLOC_SIZ	15-10
bt_set_info BT_INFO_KFREE_BUF	15-10
Additional Bind Buffer Information	15-11
Mapping and Binding to VMEbus Space	15-13
bt_hw_map_vme	15-13
bt_hw_unmap_vme	15-14
The /proc File System Interface	15-15
Example Applications	15-17
bt_bind_mult	15-18
bt_bind_multsz	15-19
bt_hwmap	15-19
bt_hwunmap	15-19
readdma	15-20
shmat	15-20
shmbind	15-20
shmconfig-script	15-21
vme-mappings	15-21
writemem	15-21
writedma	15-21

Appendix A Example Message Queue Programs A-1

POSIX Message Queue Example	A-1
System V Message Queue Example	A-4

Appendix B	Kernel Tunables for Real-time Features	B-1
Appendix C	Capabilities	C-1
	Overview	C-1
	Capabilities	C-1
Appendix D	Kernel Trace Events	D-1
	Pre-defined Kernel Trace Events	D-1
	User-defined Kernel Trace Events	D-4
	Pre-defined CUSTOM Trace Event	D-4
	Dynamic Kernel Tracing	D-4
Appendix E	Migrating 32-bit Code to 64-bit Code	E-1
	Introduction	E-1
	Procedures	E-2
	Coding Requirements	E-3
	Data Type Sizes	E-3
	Longs	E-3
	Pointers	E-3
	Arrays	E-4
	Declarations	E-4
	Explicit Data Sizes	E-4
	Constants	E-5
	APIs	E-5
	Calling Conventions	E-5
	Conditional Compilation	E-6
	Miscellaneous	E-6
	Compiling	E-6
	Testing/Debugging	E-6
	Performance Issues	E-7
	Memory Alignment and Structure Padding	E-7
Appendix F	Kernel-level Daemons on Shielded CPUs	F-1
Appendix G	Cross Processor Interrupts on Shielded CPUs	G-1
	Overview	G-1
	Memory Type Range Register (MTRR) Interrupts	G-1
	Graphics Interrupts	G-3
	NVIDIA CUDA Interrupts	G-4
	User Address Space TLB Flush Interrupts	G-5

Appendix H Serial Console Setup	H-1
Appendix I Boot Command Line Parameters	I-1
Glossary	Glossary-1
Index	Index-1

Screens

Screen 11-1 Kernel Configuration GUI	11-3
Screen 11-2 Kernel Configuration GUI Adding Serial Card Support	11-6

Illustrations

Figure 2-1 Normal Process Dispatch Latency	2-3
Figure 2-2 Effect of Disabling Interrupts on Process Dispatch Latency	2-4
Figure 2-3 Effect of High Priority Interrupt on Process Dispatch Latency	2-5
Figure 2-4 Effect of Low Priority Interrupt on Process Dispatch Latency	2-6
Figure 2-5 Effect of Multiple Interrupts on Process Dispatch Latency	2-7
Figure 2-6 Effect of Disabling Preemption on Process Dispatch Latency	2-8
Figure 2-7 Quad Opteron I/O Throughput Layout	2-28
Figure 2-8 The Standard Shielded CPU Model	2-31
Figure 2-9 Shielding with Interrupt Isolation	2-32
Figure 2-10 Hyper-thread Shielding	2-33
Figure 3-1 Definition of msqid_ds Structure	3-5
Figure 3-2 Definition of ipc_perm Structure	3-5
Figure 3-3 Definition of shmid_ds Structure	3-17
Figure 4-1 The Scheduler	4-2
Figure 5-1 Definition of sembuf Structure	5-29
Figure 5-2 Definition of semid_ds Structure	5-30
Figure 10-1 CPU/Bus Relationship on a NUMA System	10-1
Figure 11-1 Example of Complete Kernel Configuration and Build Session	11-5

Tables

Table 1-1 Pre-built Kernels	1-3
Table 2-1 Options to the shield(1) Command	2-12
Table 3-1 Message Queue Operation Permissions Codes	3-8
Table 3-2 Shared Memory Operation Permissions Codes	3-20
Table 3-3 Options to the shmconfig(1) Command	3-26
Table 5-1 Semaphore Operation Permissions Codes	5-33
Table 14-1 Types of Bottom Halves	14-13
Table 15-1 PCI-to-VME Library Functions	15-8
Table 15-2 PCI-to-VME Example Programs	15-17
Table B-1 Kernel Tunables for Real-time Features	B-2
Table D-1 Pre-defined Kernel Trace Events	D-1
Table E-1 Sizes of Data Types	E-3
Table E-2 Variable Size Data Types	E-4
Table E-3 Fixed Precision Data Types	E-4
Table E-4 Calling Conventions	E-5
Table E-5 Macros for Conditional Compilation	E-6
Table I-1 Boot Command Line Parameters	I-2

This chapter provides an introduction to RedHawk Linux and gives an overview of the real-time features included in this operating system.

Overview

Concurrent Computer Corporation's RedHawk™ Linux® is a real-time version of the open source Linux operating system. Modifications are made to the standard Linux version 2.6 kernel to support the functionality and the performance required by complex time-critical applications. RedHawk uses a single kernel design to support a single programming environment that directly controls all system operation. This design allows deterministic program execution and response to interrupts while simultaneously providing high I/O throughput and deterministic file, networking, and graphics I/O operations. RedHawk is the ideal Linux environment for the deterministic applications found in simulation, data acquisition, industrial control and medical imaging systems.

Included with RedHawk is the popular Red Hat® Enterprise Linux distribution. The installation discs provide additional real-time kernels and libraries for accessing specific kernel features. Except for the kernel, all Red Hat components operate in their standard fashion. These include Linux utilities, libraries, compilers, tools and installer unmodified from Red Hat. Optionally, the NightStar™ RT development tool set is available for developing time-critical applications, and the Frequency-Based Scheduler and Performance Monitor can be used to schedule processes in cyclical execution patterns and monitor performance.

The RedHawk kernel integrates both open source patches and Concurrent developed features to provide a state of the art real-time kernel. Many of these features have been derived from the real-time UNIX® implementations that Concurrent has supported in its over 40 years experience developing real-time operating systems. These features are described briefly in the section "Real-Time Features" later in this chapter with references to more detailed information.

RedHawk is included with each Concurrent iHawk system. iHawks are symmetric multi-processor (SMP) systems available in a variety of architectures and configurations. Either 32-bit or 64-bit versions of the operating system and its supporting software products are installed, depending upon the iHawk architecture type and the support included in RedHawk for that architecture.

Support for SMPs is highly optimized. A unique concept known as *shielded CPUs* allows a subset of processors to be dedicated to tasks that require the most deterministic performance. Individual CPUs can be shielded from interrupt processing, kernel daemons, interrupt bottom halves, and other Linux tasks. Processor shielding provides a highly deterministic execution environment where interrupt response of less than 30 microseconds is guaranteed.

RedHawk Linux has at least the same level of POSIX conformance as other Linux distributions based on the 2.6 series of kernels. Concurrent has added additional POSIX compliance by adding some of the POSIX real-time extensions that are not present in standard Linux. Linux on the Intel x86 architecture has defined a defacto binary standard of its own which allows shrink-wrapped applications that are designed to run on the Linux/Intel x86 platform to run on Concurrent's iHawk platform.

NightStar RT is Concurrent's powerful tool set that provides a robust graphic interface for non-intrusive control, monitoring, analysis, and debugging of time-critical multiprocessing applications. The RedHawk kernel contains enhancements that allow these tools to efficiently perform their operations with a minimum of interference to the application's execution. All tools can be run natively on the same system as the application or remotely for less intrusive application control.

The NightStar RT tools include the following. Refer to the individual User's Guides for complete information.

- NightView™ source-level debugger – allows multi-language, multi-processor, multi-program and multi-thread monitoring and debugging from a single graphical interface. NightView has the capability to hot patch running programs to modify execution, retrieve or modify data and insert conditional breakpoints, monitor points and watch points that execute at full application speed.
- NightTrace™ run-time analyzer – used to analyze the dynamic behavior of a running application. User and system activities are logged and marked with high-resolution time stamps. These events are then graphically displayed to provide a detailed view of system activity that occurs while the application is running. NightTrace is ideal for viewing interactions between multiple processes, activity on multiple processors, applications that execute on distributed systems and user/kernel interactions. Its powerful capabilities allow searching for specific events or summarizing kernel or user states.
- NightSim™ periodic scheduler – allows the user to easily schedule applications that require periodic execution. A developer can dynamically control the execution of multiple coordinated processes, their priorities and CPU assignments. NightSim provides detailed, highly accurate performance statistics and allows various actions when frame overruns occur.
- NightProbe™ data monitor – used to sample, record or modify program data in multiple running programs. Program data is located with a symbol table browser. Application pages are shared at the physical page level to minimize the impact on the application's execution. NightProbe can be used for debugging, analysis, fault injection or in a production environment to create a GUI control panel for program input and output.
- NightTune™ performance tuner – a graphical tool for analyzing system and application performance including CPU usage, context switches, interrupts, virtual memory usage, network activity, process attributes, and CPU shielding. NightTune allows you to change the priority, scheduling policy, and CPU affinity of individual or groups of processes using pop-up dialogs or drag-and-drop actions. It also allows you to set the shielding and hyper-threading attributes of CPUs and change the CPU assignment of individual interrupts.

RedHawk Linux Kernels

There are three flavors of RedHawk Linux kernels. The system administrator can select which version of the kernel is loaded via the boot loader. Table 1-1 provides a complete description of each pre-built kernel.

Table 1-1 Pre-built Kernels

Kernel Type	Generic	Trace	Debug
Kernel Name *	vmlinux-<i>kernelversion</i>-RedHawk-<i>x.x</i>	vmlinux-<i>kernelversion</i>-RedHawk-<i>x.x</i>-trace	vmlinux-<i>kernelversion</i>-RedHawk-<i>x.x</i>-debug
Recommended Use	Running time-critical applications	Using NightStar RT tools to evaluate performance	Developing new applications or drivers
Description	The generic kernel is the most optimized and will provide the best overall performance, however it lacks certain features required to take full advantage of the NightStar RT tools.	The trace kernel is recommended for most users as it supports all of the features of the generic kernel and provides support for the kernel tracing feature of the NightTrace performance analysis tool. This kernel is loaded at system boot by default.	The debug kernel supports all of the features of the trace kernel and in addition provides support for kernel-level debugging. This kernel is recommended for developing drivers or trying to debug system problems.
Features			
Kernel Debuggers	disabled	disabled	enabled
System Dumps	enabled	enabled	enabled
Kernel Tracing (used by NightTrace)	disabled	enabled	enabled
High Resolution Process Accounting	enabled	enabled	enabled
NMI Watchdog	disabled	disabled	enabled
Frequency Based Scheduler (FBS)	enabled when module is loaded	enabled when module is loaded	enabled when module is loaded
Performance Monitor (PM)	disabled	enabled	enabled
* <i>kernelversion</i> is the official version of Linux kernel source code upon which the kernel is based. <i>x.x</i> indicates the version number. Example: vmlinux-2.6.26.6-RedHawk-5.2.			

System Updates

RedHawk Linux updates can be downloaded from Concurrent's RedHawk Updates website. Refer to the *RedHawk Linux Release Notes* for details.

NOTE

Concurrent does not recommend downloading Red Hat updates.

The RedHawk Linux kernel replaces the standard Red Hat kernel and is likely to work with any version of the Red Hat distribution. However, installing upgrades, especially to **gcc** and **glibc**, from sources other than Concurrent may destabilize the system and is not recommended. Security updates from outside sources may be installed if desired.

Real-Time Features

This section provides a brief description of the features included in the operating system for real-time processing and performance. More detailed information about the functionality described below is provided in subsequent chapters of this guide. Online readers can display the information immediately by clicking on the chapter references.

Processor Shielding

Concurrent has developed a method of shielding selected CPUs from the unpredictable processing associated with interrupts and system daemons. By binding critical, high-priority tasks to particular CPUs and directing most interrupts and system daemons to other CPUs, the best process dispatch latency possible on a particular CPU in a multiprocessor system can be achieved. Chapter 2 presents a model for shielding CPUs and describes techniques for improving response time and increasing determinism.

Processor Affinity

In a real-time application where multiple processes execute on multiple CPUs, it is desirable to have explicit control over the CPU assignments of all processes in the system. This capability is provided by Concurrent through the **mpadvise(3)** library routine and the **run(1)** command. See Chapter 2 and the man pages for additional information.

User-level Preemption Control

When an application has multiple processes that can run on multiple CPUs and those processes operate on data shared between them, access to the shared data must be protected to prevent corruption from simultaneous access by more than one process. The most efficient mechanism for protecting shared data is a spin lock; however, spin locks cannot be effectively used by an application if there is a possibility that the application can be preempted while holding the spin lock. To remain effective, RedHawk provides a mechanism that allows the application to quickly disable preemption. See Chapter 5 and the `resched_cntl(2)` man page for more information about user-level preemption control.

Fast Block/Wake Services

Many real-time applications are composed of multiple cooperating processes. These applications require efficient means for doing inter-process synchronization. The fast block/wake services developed by Concurrent allow a process to quickly suspend itself awaiting a wakeup notification from another cooperating process. See Chapter 2, Chapter 5 and the `postwait(2)` and `server_block(2)` man pages for more details.

RCIM Driver

A driver has been added for support of the Real-Time Clock and Interrupt Module (RCIM). This multi-purpose PCI card has the following functionality:

- connection of up to twelve external device interrupts
- up to eight real time clocks that can interrupt the system
- up to twelve programmable interrupt generators which allow generation of an interrupt from an application program

These functions can all generate local interrupts on the system where the RCIM card is installed. Multiple RedHawk Linux systems can be chained together, allowing up to twelve of the local interrupts to be distributed to other RCIM-connected systems. This allows one timer or one external interrupt or one application program to interrupt multiple RedHawk Linux systems almost simultaneously to create synchronized actions. In addition, the RCIM contains a synchronized high-resolution clock so that multiple systems can share a common time base. See Chapter 6 of this guide and the *Real-Time Clock & Interrupt Module (RCIM) User's Guide* for additional information.

Frequency-Based Scheduler

The Frequency-Based Scheduler (FBS) is a mechanism for scheduling applications that run according to a predetermined cyclic execution pattern. The FBS also provides a very fast mechanism for waking a process when it is time for that process to execute. In addition, the performance of cyclical applications can be tracked, with various options available to the programmer when deadlines are not being met. The FBS is the kernel

mechanism that underlies the NightSim GUI for scheduling cyclical applications. See the *Frequency-Based Scheduler (FBS) User's Guide* and *NightSim RT User's Guide* for additional information.

/proc Modifications

Modifications have been made to the process address space support in `/proc` to allow a privileged process to read or write the values in another process' address space. This is for support of the NightProbe data monitoring tool and the NightView debugger.

Kernel Trace Facility

Support was added to allow kernel activity to be traced. This includes mechanisms for inserting and enabling kernel trace points, reading trace memory buffers from the kernel, and managing trace buffers. The kernel trace facility is used by the NightTrace tool. See Appendix D for information about kernel tracing.

ptrace Extensions

The ptrace debugging interface in Linux has been extended to support the capabilities of the NightView debugger. Features added include:

- the capability for a debugger process to read and write memory in a process not currently in the stopped state
- the capability for a debugger to trace only a subset of the signals in a process being debugged
- the capability for a debugger to efficiently resume execution at a new address within a process being debugged
- the capability for a debugger process to automatically attach to all children of a process being debugged

Kernel Preemption

The ability for a high priority process to preempt a lower priority process that is currently executing inside the kernel is provided. Under standard Linux the lower priority process would continue running until it exited from the kernel, creating longer worst case process dispatch latency. Data structure protection mechanisms are built into the kernel to support symmetric multiprocessing.

Real-Time Scheduler

The real-time scheduler provides fixed-length context switch times regardless of how many processes are active in the system. It also provides a true real-time scheduling class that operates on a symmetric multiprocessor.

Low Latency Enhancements

In order to protect shared data structures used by the kernel, the kernel protects code paths that access these shared data structures with spin locks and semaphores. The locking of a spin lock requires that preemption, and sometimes interrupts, be disabled while the spin lock is held. A study was made which identified the worst-case preemption off times. The low latency enhancements modify the algorithms in the identified worst-case preemption off scenarios to provide better interrupt response times.

Priority Inheritance

Semaphores used as sleepy-wait mutual exclusion mechanisms can introduce the problem of priority inversion. Priority inversion occurs when one or more low-priority processes executing in a critical section prevent the progress of one or more high-priority processes. Priority inheritance involves temporarily raising the priority of the low priority processes executing in the critical section to that of the highest priority waiting process. This ensures that the processes executing in the critical section have sufficient priority to continue execution until they leave the critical section. See Chapter 5 for details.

High Resolution Process Accounting

In the standard Linux kernel, the system accounts for a process' CPU execution times using a very coarse-grained mechanism. This means that the amount of CPU time charged to a particular process can be very inaccurate. The high resolution process accounting facility provides a mechanism for very accurate CPU execution time accounting, allowing better performance monitoring of applications. This facility is incorporated in the "debug" and "trace" kernels supplied by Concurrent and used by standard Linux CPU accounting services and the Performance Monitor on those kernels. See Chapter 7 for information about CPU accounting methods.

Capabilities Support

The Pluggable Authentication Module (PAM) provides a mechanism to assign privileges to users and set authentication policy without having to recompile authentication programs. Under this scheme, a non-root user can be configured to run applications that require privileges only root would normally be allowed. For example, the ability to lock pages in memory is provided by one predefined privilege that can be assigned to individual users or groups.

Privileges are granted through roles defined in a configuration file. A role is a set of valid Linux capabilities. Defined roles can be used as a building block in subsequent roles, with

the new role inheriting the capabilities of the previously defined role. Roles are assigned to users and groups, defining their capabilities on the system.

See Chapter 13 for information about the PAM functionality.

Kernel Debuggers

The open source kernel debugger **kdb** is supported on RedHawk Linux “debug” kernels.

More information can be found in Chapter 12.

Kernel Core Dumps/Crash Analysis

The **kexec** and **kdump** open source patches enable another kernel to load and capture a crash dump, and the **crash** utility is provided for analyzing the dump. See Chapter 12 for more information about crash dump analysis.

User-level Spin Locks

RedHawk Linux busy-wait mutual exclusion tools include a low-overhead busy-wait mutual exclusion variable (a spin lock) and a corresponding set of macros that allow you to initialize, lock, unlock and query spin locks. To be effective, user-level spin locks must be used with user-level preemption control. Refer to Chapter 5 for details.

usermap and /proc mmap

The **usermap(3)** library routine, which resides in the **libccur_rt** library, provides applications with a way to efficiently monitor and modify locations in currently executing programs through the use of simple CPU reads and writes.

The **/proc** file system **mmap(2)** is the underlying kernel support for **usermap(3)**, which lets a process map portions of another process' address space into its own address space. Thus, monitoring and modifying other executing programs becomes simple CPU reads and writes within the application's own address space, without incurring the overhead of **/proc** file system **read(2)** and **write(2)** system service calls. Refer to Chapter 9 for more information.

Hyper-threading

Hyper-threading is a feature of the Intel Pentium Xeon processor. It allows for a single physical processor to appear to the operating system as two logical processors. Two program counters run simultaneously within each CPU chip so that in effect, each chip is a dual-CPU SMP. With hyper-threading, physical CPUs can run multiple tasks “in parallel” by utilizing fast hardware-based context-switching between the two register sets upon things like cache-misses or special instructions. RedHawk Linux includes support for hyper-threading. Refer to Chapter 2 for more information on how to effectively use this feature in a real-time environment.

XFS Journaling File System

The XFS journaling file system from SGI is implemented in RedHawk Linux. Journaling file systems use a journal (log) to record transactions. In the event of a system crash, the background process is run on reboot and finishes copying updates from the journal to the file system. This drastically cuts the complexity of a file system check, reducing recovery time. The SGI implementation is a multithreaded, 64-bit file system capable of large files and file systems, extended attributes, variable block sizes, is extent based and makes extensive use of Btrees to aid both performance and scalability. Refer to Chapter 8 for more information.

POSIX Real-Time Extensions

RedHawk Linux supports most of the interfaces defined by the POSIX real-time extensions as set forth in ISO/IEC 9945-1. The following functional areas are supported:

- user priority scheduling
- process memory locking
- memory mapped files
- shared memory
- message queues
- counting semaphores
- real-time signal behavior
- asynchronous I/O
- synchronized I/O
- timers (high resolution version is supported)

User Priority Scheduling

RedHawk Linux accommodates user priority scheduling—that is, processes scheduled under the fixed-priority POSIX scheduling policies do not have their priorities changed by the operating system in response to their run-time behavior. The resulting benefits are reduced kernel overhead and increased user control. Process scheduling facilities are fully described in Chapter 4.

Memory Resident Processes

Paging and swapping often add an unpredictable amount of system overhead time to application programs. To eliminate performance losses due to paging and swapping, RedHawk Linux allows you to make certain portions of a process' virtual address space resident. The `mlockall(2)`, `munlockall(2)`, `mlock(2)`, and `munlock(2)` POSIX system calls allow locking all or a portion of a process' virtual address space in physical memory. See the man pages for details.

Memory Mapping and Data Sharing

RedHawk Linux supports shared memory and memory-mapping facilities based on IEEE Standard 1003.1b-1993, as well as System V IPC mechanisms. The POSIX facilities allow processes to share data through the use of *memory objects*, named regions of storage that can be mapped to the address space of one or more processes to allow them to share the associated memory. The term *memory object* includes POSIX shared memory objects, regular files, and some devices, but not all file system objects (terminals and network devices, for example). Processes can access the data in a memory object directly by mapping portions of their address spaces onto the objects. This is generally more efficient than using the `read(2)` and `write(2)` system calls because it eliminates copying the data between the kernel and the application.

Process Synchronization

RedHawk Linux provides a variety of tools that cooperating processes can use to synchronize access to shared resources.

Counting semaphores based on IEEE Standard 1003.1b-1993 allow multiple threads in a multithreaded process to synchronize their access to the same set of resources. A counting semaphore has a value associated with it that determines when resources are available for use and allocated. System V IPC semaphore sets, which support interprocess semaphores, are also available.

In addition to semaphores, a set of real-time process synchronization tools developed by Concurrent provides the ability to control a process' vulnerability to rescheduling, serialize processes' access to critical sections with busy-wait mutual exclusion mechanisms, and coordinate client-server interaction among processes. With these tools, a mechanism for providing sleepy-wait mutual exclusion with bounded priority inversion can be constructed.

Descriptions of the synchronization tools and procedures for using them are provided in Chapter 5.

Asynchronous Input/Output

Being able to perform I/O operations asynchronously means that you can set up for an I/O operation and return without blocking on I/O completion. RedHawk Linux accommodates asynchronous I/O with a group of library routines based on IEEE Standard 1003.1b-1993. These interfaces allow a process to perform asynchronous read and write operations, initiate multiple asynchronous I/O operations with a single call, wait for completion of an asynchronous I/O operation, cancel a pending asynchronous I/O operation, and perform asynchronous file synchronization. The "aio" functions are documented in info pages ("info libc") on the system.

Synchronized Input/Output

RedHawk Linux also supports the synchronized I/O facilities based on IEEE Standard 1003.1b-1993. POSIX synchronized I/O provides the means for ensuring the integrity of an application's data and files. A synchronized output operation ensures the recording of data written to an output device. A synchronized input operation ensures that the data read from a device mirrors the data currently residing on disk. Refer to the man pages for more information.

Real-Time Signal Behavior

Real-time signal behavior specified by IEEE Standard 1003.1b-1993 includes specification of a range of real-time signal numbers, support for queuing of multiple occurrences of a particular signal, and support for specification of an application-defined value when a signal is generated to differentiate among multiple occurrences of signals of the same type. The POSIX signal-management facilities include the **sigtimedwait(2)**, **sigwaitinfo(2)**, and **sigqueue(2)** system calls, which allow a process to wait for receipt of a signal and queue a signal and an application-defined value to a process. Refer to the man pages for more information.

Clocks and Timers

Support for high-resolution POSIX clocks and timers is included in RedHawk. System-wide POSIX clocks can be used for such purposes as time Linuxstamping or measuring the length of code segments. POSIX timers allow applications to use relative or absolute time based on a high resolution clock and to schedule events on a one-shot or periodic basis. Applications can create multiple timers for each process. In addition, high-resolution sleep mechanisms are provided which can be used to put a process to sleep for a very short time quantum and specify which clock should be used for measuring the duration of the sleep. See Chapter 6 for additional information.

Message Queues

POSIX message passing facilities based on IEEE Standard 1003.1b-1993 are included in RedHawk Linux, implemented as a file system. POSIX message queue library routines allow a process to create, open, query and destroy a message queue, send and receive messages from a message queue, associate a priority with a message to be sent, and request asynchronous notification when a message arrives. POSIX message queues operate independently of System V IPC messaging, which is also available. See Chapter 3 for details.

Real-Time Performance

This chapter discusses some of the issues involved with achieving real-time performance under RedHawk Linux. The primary focus of the chapter is on the *Shielded CPU Model*, which is a model for assigning processes and interrupts to a subset of CPUs in the system to attain the best real-time performance.

Key areas of real-time performance are discussed: interrupt response, process dispatch latency and deterministic program execution. The impact of various system activities on these metrics is discussed and techniques are given for optimum real-time performance.

Overview of the Shielded CPU Model

The shielded CPU model is an approach for obtaining the best real-time performance in a symmetric multiprocessor system. The shielded CPU model allows for both deterministic execution of a real-time application as well as deterministic response to interrupts.

A task has deterministic execution when the amount of time it takes to execute a code segment within that task is predictable and constant. Likewise the response to an interrupt is deterministic when the amount of time it takes to respond to an interrupt is predictable and constant. When the worst-case time measured for either executing a code segment or responding to an interrupt is significantly different than the typical case, the application's performance is said to be experiencing *jitter*. Because of computer architecture features like memory caches and contention for shared resources, there will always be some amount of jitter in measurements of execution times. Each real-time application must define the amount of jitter that is acceptable to that application.

In the shielded CPU model, tasks and interrupts are assigned to CPUs in a way that guarantees a high grade of service to certain important real-time functions. In particular, a high-priority task is bound to one or more shielded CPUs, while most interrupts and low priority tasks are bound to *other* CPUs. The CPUs responsible for running the high-priority tasks are shielded from the unpredictable processing associated with interrupts and the other activity of lower priority processes that enter the kernel via system calls, thus these CPUs are called *shielded CPUs*.

Some examples of the types of tasks that should be run on shielded CPUs are:

- tasks that require guaranteed interrupt response time
- tasks that require the fastest interrupt response time
- tasks that must be run at very high frequencies
- tasks that require deterministic execution in order to meet their deadlines
- tasks that have no tolerance for being interrupted by the operating system

There are several levels of CPU shielding that provide different degrees of determinism for the tasks that must respond to high-priority interrupts or that require deterministic execution. Before discussing the levels of shielding that can be enabled on a shielded CPU, it is necessary to understand how the system responds to external events and how some of the normal operations of a computer system impact system response time and determinism.

Overview of Determinism

Determinism refers to a computer system's ability to execute a particular code path (a set of instructions executed in sequence) in a fixed amount of time. The extent to which the execution time for the code path varies from one instance to another indicates the degree of determinism in the system.

Determinism applies not only to the amount of time required to execute a time-critical portion of a user's application but also to the amount of time required to execute system code in the kernel. The determinism of the process dispatch latency, for example, depends upon the code path that must be executed to handle an interrupt, wake the target process, perform a context switch, and allow the target process to exit from the kernel. (The section "Process Dispatch Latency" defines the term *process dispatch latency* and presents a model for obtaining the best process dispatch latency possible on a particular CPU in a multiprocessor system.)

The largest impact on the determinism of a program's execution is the receipt of interrupts. This is because interrupts are always the highest priority activity in the system and the receipt of an interrupt is unpredictable – it can happen at any point in time while a program is executing. Shielding from non-critical interrupts will have the largest impact on creating better determinism during the execution of high priority tasks.

Other techniques for improving the determinism of a program's execution are discussed in the section called "Procedures for Increasing Determinism."

Process Dispatch Latency

Real-time applications must be able to respond to a real-world event and complete the processing required to handle that real-world event within a given deadline. Computations required to respond to the real-world event must be complete before the deadline or the results are considered incorrect. A single instance of having an unusually long response to an interrupt can cause a deadline to be missed.

The term *process dispatch latency* denotes the time that elapses from the occurrence of an external event, which is signified by an interrupt, until the process waiting for that external event executes its first instruction in user mode. For real-time applications, the worst-case process dispatch latency is a key metric, since it is the worst-case response time that will determine the ability of the real-time application to guarantee that it can meet its deadlines.

Process dispatch latency comprises the time that it takes for the following sequence of events to occur:

1. The interrupt controller notices the interrupt and generates the interrupt exception to the CPU.
2. The interrupt routine is executed, and the process waiting for the interrupt (target process) is awakened.
3. The currently executing process is suspended, and a context switch is performed so that the target process can run.
4. The target process must exit from the kernel, where it was blocked waiting for the interrupt.
5. The target process runs in user mode.

This sequence of events represents the ideal case for process dispatch latency; it is illustrated by Figure 2-1. Note that events 1-5 described above, are marked in Figure 2-1.

Figure 2-1 Normal Process Dispatch Latency

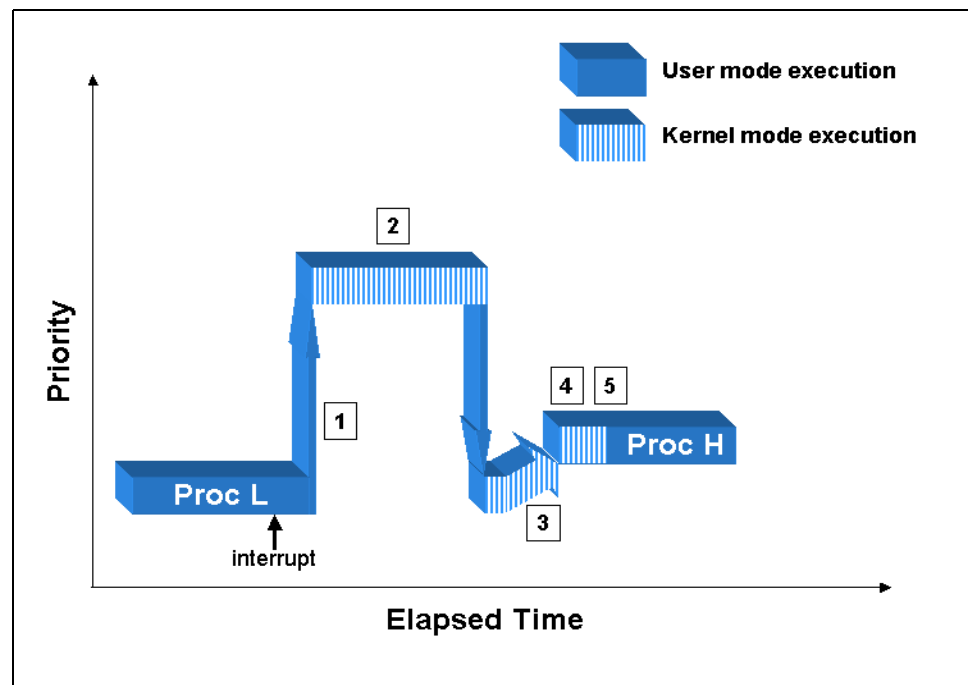

The process dispatch latency is a very important metric for event-driven real-time applications because it represents the speed with which the application can respond to an external event. Most developers of real-time applications are interested in the worst-case process dispatch latency because their applications must meet certain timing constraints.

Process dispatch latency is affected by some of the normal operations of the operating system, device drivers and computer hardware. The following sections examine some of the causes of jitter in process dispatch latency.

Effect of Disabling Interrupts

An operating system must protect access to shared data structures in order to prevent those data structures from being corrupted. When a data structure can be accessed at interrupt level, it is necessary to disable interrupts whenever that data structure is accessed. This prevents interrupt code from corrupting a shared data structure should it interrupt program level code in the midst of an update to the same shared data structure. This is the primary reason that the kernel will disable interrupts for short periods of time.

When interrupts are disabled, process dispatch latency is affected because the interrupt that we are trying to respond to cannot become active until interrupts are again enabled. In this case, the process dispatch latency for the task awaiting the interrupt is extended by the amount of time that interrupts remain disabled. This is illustrated in Figure 2-2. In this diagram, the low priority process has made a system call which has disabled interrupts. When the high priority interrupt occurs it cannot be acted on because interrupts are currently disabled. When the low priority process has completed its critical section, it enables interrupts, the interrupt becomes active and the interrupt service routine is called. The normal steps of interrupt response then complete in the usual fashion. Note that the numbers 1-5 marked in Figure 2-2 represent the steps of normal process dispatch latency as described earlier on page 2-3.

Obviously, critical sections in the operating system where interrupts are disabled must be minimized to attain good worst-case process dispatch latency.

Figure 2-2 Effect of Disabling Interrupts on Process Dispatch Latency

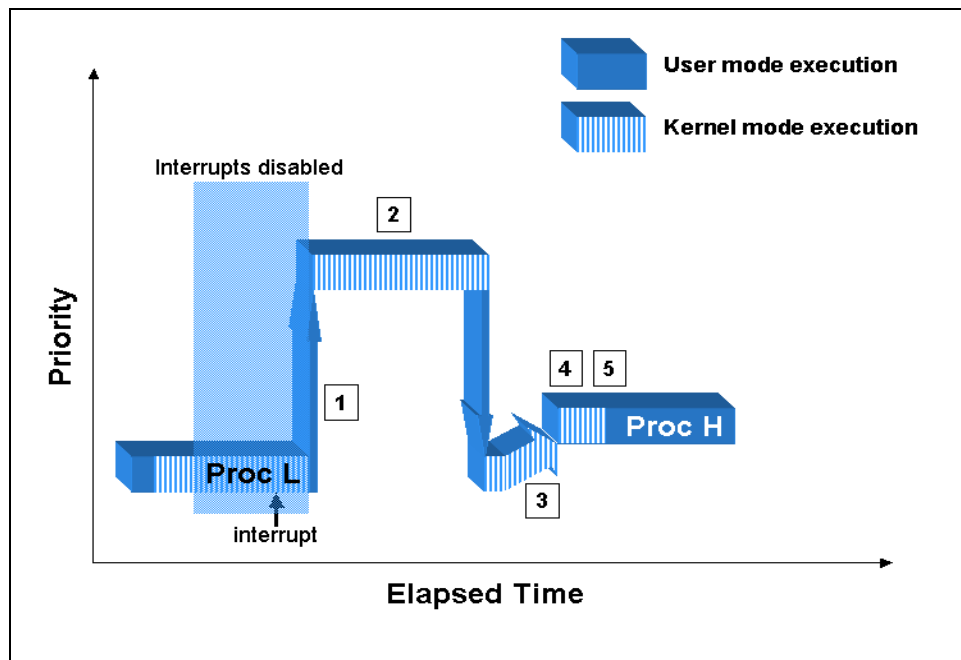

Effect of Interrupts

The receipt of an interrupt affects process dispatch latency in much the same way that disabling interrupts does. When a hardware interrupt is received, the system will block interrupts of the same or lesser priority than the current interrupt. The simple case is illustrated in Figure 2-3, where a higher priority interrupt occurs before the target interrupt, causing the target interrupt to be held off until the higher priority interrupt occurs. Note that the numbers 1-5 marked in Figure 2-3 represent the steps of normal process dispatch latency as described earlier on page 2-3.

Figure 2-3 Effect of High Priority Interrupt on Process Dispatch Latency

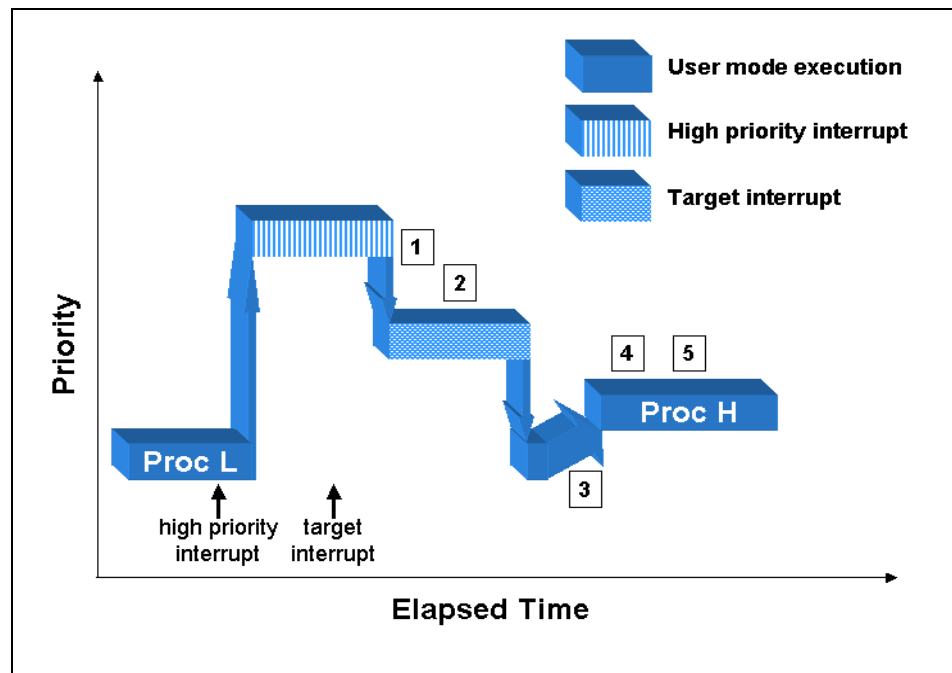

The relative priority of an interrupt does not affect process dispatch latency. Even when a low priority interrupt becomes active, the impact of that interrupt on the process dispatch latency for a high-priority interrupt is the same. This is because interrupts always run at a higher priority than user-level code. Therefore, even though we might service the interrupt routine for a high-priority interrupt, that interrupt routine cannot get the user-level context running until all interrupts have completed their execution. This impact of a low priority interrupt on process dispatch latency is illustrated in Figure 2-4. Note that the ordering of how things are handled is different than the case of the high-priority interrupt in Figure 2-3, but the impact on process dispatch latency is the same. Note that the numbers 1-5 marked in Figure 2-4 represent the steps of normal process dispatch latency as described earlier on page 2-3.

Figure 2-4 Effect of Low Priority Interrupt on Process Dispatch Latency

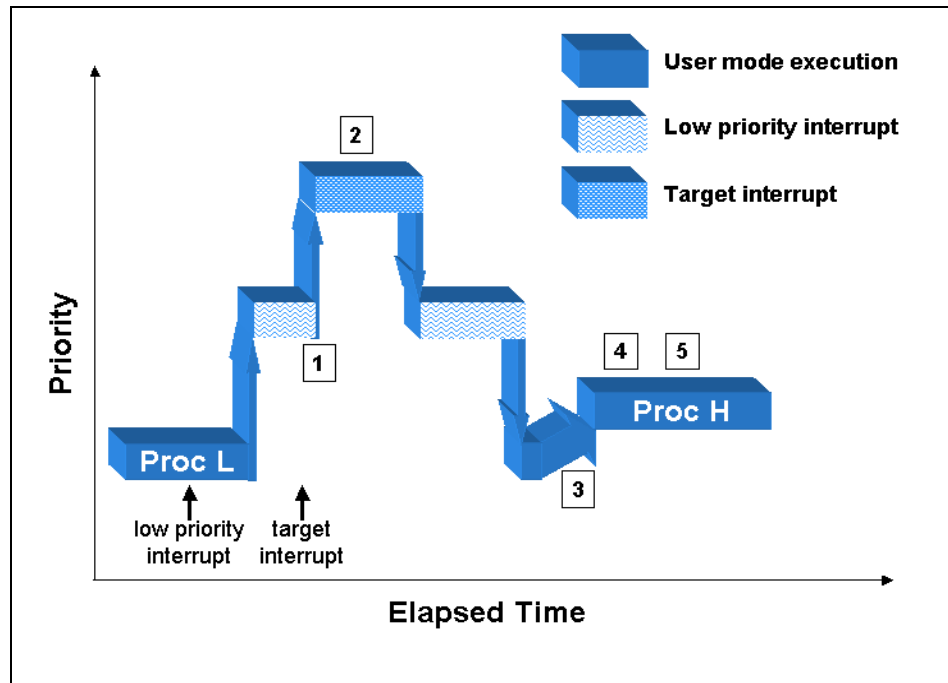

One of the biggest differences between the effect of disabling interrupts and receipt of an interrupt in terms of the impact on process dispatch latency is the fact that interrupts occur asynchronously to the execution of an application and at unpredictable times. This is important to understanding the various levels of shielding that are available.

When multiple interrupts can be received on a given CPU, the impact on worst-case process dispatch latency can be severe. This is because interrupts can stack up, such that more than one interrupt service routine must be processed before the process dispatch latency for a high priority interrupt can be completed. Figure 2-5 shows a case of two interrupts becoming active while trying to respond to a high priority interrupt. Note that the numbers 1-5 marked in Figure 2-5 represent the steps of normal process dispatch latency as described earlier on page 2-3. When a CPU receives an interrupt, that CPU will disable interrupts of lower priority from being able to interrupt the CPU. If a second interrupt of lower-priority becomes active during this time, it is blocked as long as the original interrupt is active. When servicing of the first interrupt is complete, the second interrupt becomes active and is serviced. If the second interrupt is of higher priority than the initial interrupt, it will immediately become active. When the second interrupt completes its processing, the first interrupt will again become active. In both cases, user processes are prevented from running until all of the pending interrupts have been serviced.

Conceivably, it would be possible for a pathological case where interrupts continued to become active, never allowing the system to respond to the high-priority interrupt. When multiple interrupts are assigned to a particular CPU, process dispatch latency is less predictable on that CPU because of the way in which the interrupts can be stacked.

Figure 2-5 Effect of Multiple Interrupts on Process Dispatch Latency

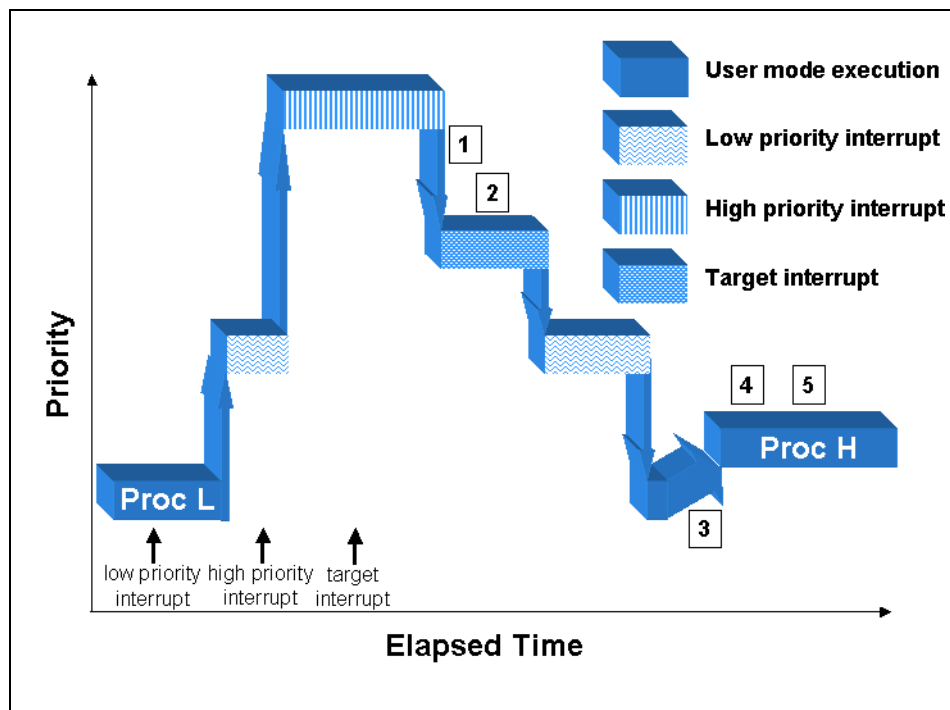

Effect of Disabling Preemption

There are critical sections in RedHawk Linux that protect a shared resource that is never locked at interrupt level. In this case, there is no reason to block interrupts while in this critical section. However, a preemption that occurs during this critical section could cause corruption to the shared resource if the new process were to enter the same critical section. Therefore, preemption is disabled while a process executes in this type of critical section. Blocking preemption will not delay the receipt of an interrupt. However, if that interrupt wakes a high priority process, it will not be possible to switch to that process until preemption has again been enabled. Assuming the same CPU is required, the actual effect on worst-case process dispatch latency is the same as if interrupts had been disabled. The effect of disabling preemption on process dispatch latency is illustrated in Figure 2-6. Note that the numbers 1-5 marked in Figure 2-6 represent the steps of normal process dispatch latency as described earlier on page 2-3.

Figure 2-6 Effect of Disabling Preemption on Process Dispatch Latency

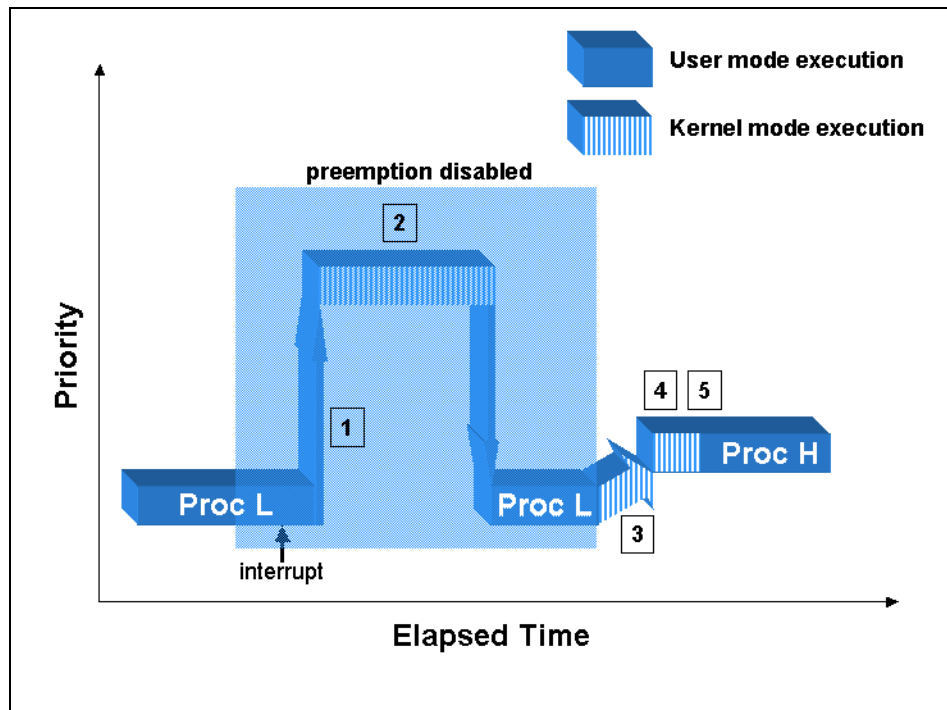

Effect of Open Source Device Drivers

Device drivers are a part of the Linux kernel, because they run in supervisor mode. This means that device drivers are free to call Linux functions that disable interrupts or disable preemption. Device drivers also handle interrupts, therefore they control the amount of time that might be spent at interrupt level. As shown in previous sections of this chapter, these actions have the potential to impact worst-case interrupt response and process dispatch latency.

Device drivers enabled in RedHawk Linux have been tested to be sure they do not adversely impact real-time performance. While open source device driver writers are encouraged to minimize the time spent at interrupt level and the time interrupts are disabled, in reality open source device drivers are written with very varied levels of care. If additional open source device drivers are enabled they may have a negative impact upon the guaranteed worst-case process dispatch latency that RedHawk Linux provides.

Refer to the “Device Drivers” chapter for more information about real-time issues with device drivers.

How Shielding Improves Real-Time Performance

This section will examine how the different attributes of CPU shielding improve both the ability for a user process to respond to an interrupt (process dispatch latency) and determinism in execution of a user process.

When enabling shielding, all shielding attributes are enabled by default. This provides the most deterministic execution environment on a shielded CPU. Each of these shielding attributes is described in more detail below. The user should fully understand the impact of each of the possible shielding attributes, as some of these attributes do have side effects to normal system functions. There are three categories of shielding attributes currently supported:

- shielding from background processes
- shielding from interrupts
- shielding from the local interrupt

Each of these attributes is individually selectable on a per-CPU basis. Each of the shielding attributes is described below.

Shielding From Background Processes

This shielding attribute allows a CPU to be reserved for a subset of processes in the system. This shielding attribute should be enabled on a CPU when you want that CPU to have the fastest, most predictable response to an interrupt. The best guarantee on process dispatch latency is achieved when only the task that responds to an interrupt is allowed to execute on the CPU where that interrupt is directed.

When a CPU is allowed to run background processes, it can affect the process dispatch latency of a high-priority task that desires very deterministic response to an interrupt directed to that CPU. This is because background processes will potentially make system calls that can disable interrupts or preemption. These operations will impact process dispatch latency as explained in the sections “Effect of Disabling Interrupts” and “Effect of Disabling Preemption.”

When a CPU is allowed to run background processes, there is no impact on the determinism in the execution of high priority processes. This assumes the background processes have lower priority than the high-priority processes. Note that background processes could affect the time it takes to wake a process via other kernel mechanisms such as signals or the `server_wake1(3)` interface.

Each process or thread in the system has a CPU affinity mask. The CPU affinity mask determines on which CPUs the process or thread is allowed to execute. The CPU affinity mask is inherited from the parent and can be set via the `mpadvise(3)` library routine or the `sched_setaffinity(2)` system call. When a CPU is shielded from processes, that CPU will only run processes and threads that have explicitly set their CPU affinity to a set of CPUs that only includes shielded CPUs. In other words, if a process has a non-shielded CPU in its CPU affinity mask, then the process will only run on those CPUs that are not shielded. To run a process or thread on a CPU shielded from background processes, it must have a CPU affinity mask that specifies ONLY shielded CPUs.

Certain kernel daemons created by Linux are replicated on every CPU in the system. Shielding a CPU from processes will not remove one of these “per-CPU” daemons from the shielded CPU. The impact of these daemons can be avoided through kernel configuration or careful control of application behavior. The kernel daemons, their functionality and methods to avoid jitter from per-CPU kernel daemons are described in Appendix F.

Shielding From Interrupts

This shielding attribute allows a CPU to be reserved for processing only a subset of interrupts received by the system. This shielding attribute should be enabled when it is desirable to have the fastest, most predictable process dispatch latency or when it is desirable to have determinism in the execution time of an application.

Because interrupts are always the highest priority activity on a CPU, the handling of an interrupt can affect both process dispatch latency and the time it takes to execute a normal code path in a high priority task. This is described in the section, “Effect of Interrupts”.

Each device interrupt is associated with an IRQ. These IRQs have an associated CPU affinity that determines which CPUs are allowed to receive the interrupt. When interrupts are not routed to a specific CPU, the interrupt controller will select a CPU for handling an interrupt at the time the interrupt is generated from the set of CPUs in the IRQ affinity mask. IRQ affinities are modified by the `shield(1)` command or through `/proc/irq/N/smp_affinity`.

On the i386 architecture, the `kirqd` daemon periodically adjusts IRQ affinities in an attempt to balance interrupt load across CPUs. This daemon conflicts with interrupt-shielding and has been disabled by default in all RedHawk Linux kernel configurations through the `IRQBALANCE` kernel configuration option. It can be enabled by enabling the

IRQBALANCE kernel parameter, which is only available when the SHIELD tunable is turned off.

Note that if it is desirable to disable all interrupts on all CPUs, the recommended procedure is to shield all CPUs from interrupts except one, then make a call to `local_irq_disable(2)` on the unshielded CPU. See the man page for details.

Certain activities can cause interrupts to be sent to shielded CPUs. These cross processor interrupts are used as a method for forcing another CPU to handle some per-CPU specific task. Cross processor interrupts can potentially cause noticeable jitter for shielded CPUs. Refer to Appendix G for a full discussion.

Shielding From Local Interrupt

The local interrupt is a special interrupt for a private timer associated with each CPU. Under RedHawk Linux, this timer is used for various timeout mechanisms in the kernel and at user level. This functionality is described in Chapter 7. By default, this interrupt is enabled on all CPUs in the system.

This interrupt fires every ten milliseconds, making the local interrupt one of the most frequently executed interrupt routines in the system. Therefore, the local interrupt is a large source of jitter to real-time applications.

When a CPU is shielded from the local timer, the local interrupt is effectively disabled and the functions provided by the local timer associated with that CPU are no longer performed; however, they continue to run on other CPUs where the local timer has not been shielded. Some of these functions will be lost, while others can be provided via other means.

One of the functions that is lost when the local interrupt is disabled on a particular CPU is the low resolution mechanism for CPU execution time accounting. This is the mechanism that measures how much CPU time is used by each process that executes on this CPU. Whenever the local interrupt fires, the last clock tick's worth of time is charged to the process that was interrupted. If high resolution process accounting is configured, then CPU time will be accurately accounted for regardless of whether or not the local interrupt is enabled. High resolution process accounting is discussed in Chapter 7, "System Clocks and Timers."

When a CPU is shielded from the local timer, the local interrupt will continue to be used for POSIX timers and nanosleep functionality by processes biased to the shielded CPU. For this reason, if it is critical to totally eliminate local timer interrupts for optimum performance on a specific shielded CPU, applications utilizing POSIX timers or nanosleep functionality should not be biased to that CPU. If a process is not allowed to run on the shielded CPU, its timers will be migrated to a CPU where the process is allowed to run.

Refer to Chapter 7, "System Clocks and Timers" for a complete discussion on the effects of disabling the local timer and alternatives that are available for some of the features.

Interfaces to CPU Shielding

This section describes both the command level and programming interfaces that can be used for setting up a shielded CPU. There is also an example that describes the common case for setting up a shielded CPU.

Shield Command

The **shield(1)** command sets specified shielding attributes for selected CPUs. The **shield** command can be used to mark CPUs as shielded CPUs. A shielded CPU is protected from some set of system activity in order to provide better determinism in the time it takes to execute application code.

The list of logical CPUs affected by an invocation of the **shield** command is given as a comma-separated list of CPU numbers or ranges.

The format for executing the **shield** command is:

```
shield [OPTIONS]
```

Options are described in Table 2-1.

In the options listed below, *CPULIST* is a list of comma separated values or a range of values representing logical CPUs. For example, the list of CPUs “**0-4,7**” specifies the following logical CPU numbers: **0,1,2,3,4,7**.

Table 2-1 Options to the shield(1) Command

Option	Description
--irq=CPULIST, -i CPULIST	Shields all CPUs in <i>CPULIST</i> from interrupts. The only interrupts that will execute on the specified CPUs are those that have been assigned a CPU affinity that would prevent them from executing on any other CPU.
--loc=CPULIST, -l CPULIST	The specified list of CPUs is shielded from the local timer. The local timer provides time-based services for a CPU. Disabling the local timer may cause some system functionality such as user/system time accounting and round-robin quantum expiration to be disabled. Refer to Chapter 7 for more a complete discussion.

Table 2-1 Options to the `shield(1)` Command (Continued)

Option	Description
<code>--proc=CPULIST, -p CPULIST</code>	The specified list of CPUs is shielded from extraneous processes. Processes that have an affinity mask that allows them to run on a non-shielded CPU only run on non-shielded CPUs. Processes that would be precluded from executing on any CPU other than a shielded CPU are allowed to execute on that shielded CPU.
<code>--all=CPULIST, -a CPULIST</code>	The specified list of CPUs will have all available shielding attributes set. See the descriptions of the individual shielding options above to understand the implications of each shielding attribute.
<code>--help, -h</code>	Describes available options and usage.
<code>--version, -V</code>	Prints out current version of the command.
<code>--reset, -r</code>	Resets shielding attributes for all CPUs. No CPUs are shielded.
<code>--current, -c</code>	Displays current settings for all active CPUs.

Refer to Chapter 10, “Non-Uniform Memory Access (NUMA)”, for options to `shield(1)` that control NUMA node memory shielding.

Shield Command Examples

The following command first resets all shielding attributes, then shields CPUs 0,1 and 2 from interrupts, then shields CPU 1 from local timer, shields CPU 2 from extraneous processes, and finally, displays all new settings after the changes:

```
shield -r -i 0-2 -l 1 -p 2 -c
```

The following command shields CPUs 1,2 and 3 from interrupts, local timer, and extraneous processes. CPU 0 is left as a “general purpose” CPU that will service all interrupts and processes not targeted to a shielded CPU. All shielding attributes are set for the list of CPUs.

```
shield --all=1-3
```

Exit Status

Normally, the exit status is zero. However, if an error occurred while trying to modify shielded CPU attributes, a diagnostic message is issued and an exit status of 1 is returned.

Shield Command Advanced Features

It is recommended that the advanced features described below should only be used by experienced users.

CPUs specified in the *CPULIST* can be preceded by a '+' or a '-' sign in which case the CPUs in the list are added to (+) or taken out of (-) the list of already shielded CPUs.

Options can be used multiple times. For example, “shield -i 0 -c -i +1 -c” shows current settings after CPU 0 has been shielded from interrupts and then displays current settings again after CPU 1 has been added to the list of CPUs shielded from interrupts.

/proc Interface to CPU Shielding

The kernel interface to CPU shielding is through the */proc* file system using the following files:

<code>/proc/shield/procs</code>	process shielding
<code>/proc/shield/irqs</code>	irq shielding
<code>/proc/shield/ltmrs</code>	local timer shielding

All users can read these files, but only root or users with the *CAP_SYS_NICE* capability and file permissions may write to them.

When read, an 8 digit ASCII hexadecimal value is returned. This value is a bitmask of shielded CPUs. Set bits identify the set of shielded CPUs. The radix position of each set bit is the number of the logical CPU being shielded by that bit.

For example:

```
00000001 - bit 0 is set so CPU #0 is shielded
00000002 - bit 1 is set so CPU #1 is shielded
00000004 - bit 2 is set so CPU #2 is shielded
00000006 - bits 1 and 2 are set so CPUs #1 and #2 are shielded
```

When written to, an 8 digit ASCII hexadecimal value is expected. This value is a bitmask of shielded CPUs in a form identical to that listed above. The value then becomes the new set of shielded CPUs.

See the `shield(5)` man page for additional information.

Assigning Processes to CPUs

This section describes the methods available for assigning a process or thread to a set of CPUs. The set of CPUs where a process is allowed to run is known as its CPU affinity.

By default, a process or thread can execute on any CPU in the system. Every process or thread has a bit mask, or CPU affinity, that determines the CPU or CPUs on which it can be scheduled. A process or thread inherits its CPU affinity from its creator during a `fork(2)` or a `clone(2)` but may change it thereafter.

You can set the CPU affinity for one or more processes or threads by specifying the `MPA_PRC_SETBIAS` command on a call to `mpadvise(3)`, or the `-b bias` option to the `run(1)` command. `sched_setaffinity(2)` can also be used to set CPU affinity.

To set the CPU affinity, the following conditions must be met:

- The real or effective user ID of the calling process must match the real or saved user ID of the process for which the CPU affinity is being set, or
- the calling process must have the `CAP_SYS_NICE` capability or be root.

To add a CPU to a process' or thread's CPU affinity, the calling process must have the `CAP_SYS_NICE` capability or be root.

A CPU affinity can be assigned to the `init(8)` process. All general processes are a descendant from `init`. As a result, most general processes would have the same CPU affinity as `init` or a subset of the CPUs in the `init` CPU affinity. Only privileged processes (as described above) are able to add a CPU to their CPU affinity. Assigning a restricted CPU affinity to `init` restricts all general processes to the same subset of CPUs as `init`. The exception is selected processes that have the appropriate capability who explicitly modify their CPU affinity. If you wish to change the CPU affinity of `init`, see the section “Assigning CPU Affinity to `init`” below for instructions.

The `mpadvise` library routine is documented in the section “Multiprocessor Control Using `mpadvise`” below and the `mpadvise(3)` man page. The `run` command is documented in the section “The `run` Command” in Chapter 4 and the `run(1)` man page. For information on `sched_setaffinity(2)` and `sched_getaffinity(2)`, see the `sched_affinity(2)` man page.

Multiprocessor Control Using `mpadvise`

`mpadvise(3)` performs a variety of multiprocessor functions. CPUs are identified by specifying a pointer to a `cpuset_t` object, which specifies a set of one or more CPUs. For more information on CPU sets, see the `cpuset(3)` man page.

Synopsis

```
#include <mpadvise.h>

int mpadvise (int cmd, int which, int who, cpuset_t *setp)

gcc [options] file -lccur_rt ...
```

Informational Commands

The following commands get or set information about the CPUs in the system. The `which` and `who` parameters are ignored.

<code>MPA_CPU_PRESENT</code>	Returns a mask indicating which CPUs are physically present in the system. CPUs brought down with the <code>cpu(1)</code> command are still included.
<code>MPA_CPU_ACTIVE</code>	Returns a mask indicating which CPUs are active, that is, initialized and accepting work, regardless of how many exist in the backplane. If a CPU has been brought down using the <code>cpu(1)</code> command, it is not included.

MPA_CPU_BOOT	Returns a mask indicating the CPU that booted the system. The boot CPU has some responsibilities not shared with the other CPUs.
MPA_CPU_LMEM	Returns a mask indicating which CPUs have local memory on a system with NUMA support. CPUs brought down with the <code>cpu (1)</code> command are still included.

Control Commands

The following commands provide control over the use of CPUs by a process, a thread, a process group, or a user.

MPA_PRC_GETBIAS	Returns the CPU set for the CPU affinity of all threads in the specified process (MPA_PID) or the exact unique bias for the specified thread (MPA_TID).
MPA_PRC_SETBIAS	Sets the CPU affinity of all threads in the specified processes (MPA_PID) or the unique CPU affinity for the specified thread (MPA_TID) to the specified cpuset. To change the CPU affinity of a process, the real or effective user ID must match the real or the saved (from <code>exec (2)</code>) user ID of the process, unless the current user has the <code>CAP_SYS_NICE</code> capability.
MPA_PRC_GETRUN	Returns a CPU set with exactly one CPU in it that corresponds to the CPU where the specified thread is currently running (or waiting to run) (MPA_TID). When MPA_PID is specified, returns one CPU for non-threaded programs and the set of CPUs in use by all threads of a multi-threaded program. Note that it is possible that the CPU assignment may have already changed by the time the value is returned.

Using *which* and *who*

<i>which</i>	Used to specify the selection criteria. Can be one of the following: <table> <tr> <td>MPA_PID</td> <td>a specific process and all its threads</td> </tr> <tr> <td>MPA_TID</td> <td>a specific thread</td> </tr> <tr> <td>MPA_PGID</td> <td>a process group</td> </tr> <tr> <td>MPA_UID</td> <td>a user</td> </tr> <tr> <td>MPA_LWPID</td> <td>same as MPA_TID (compatible with PowerMAX)</td> </tr> </table>	MPA_PID	a specific process and all its threads	MPA_TID	a specific thread	MPA_PGID	a process group	MPA_UID	a user	MPA_LWPID	same as MPA_TID (compatible with PowerMAX)
MPA_PID	a specific process and all its threads										
MPA_TID	a specific thread										
MPA_PGID	a process group										
MPA_UID	a user										
MPA_LWPID	same as MPA_TID (compatible with PowerMAX)										
<i>who</i>	Interpreted relative to <i>which</i> : <table> <tr> <td>a process identifier</td> </tr> <tr> <td>a thread identifier</td> </tr> <tr> <td>a process group identifier</td> </tr> <tr> <td>user identifier</td> </tr> </table> <p>A <i>who</i> value of 0 causes the process identifier, process group identifier, or user identifier of the caller to be used.</p>	a process identifier	a thread identifier	a process group identifier	user identifier						
a process identifier											
a thread identifier											
a process group identifier											
user identifier											

Using `MPA_PID` with a reference to a single subordinate (non-primordial) thread applies to the containing process as it does when a primordial thread is supplied.

When using `MPA_TID`, *who* must be the numeric thread ID (as returned by `gettid`), not a pthread identifier associated with the POSIX Threads library.

Assigning CPU Affinity to `init`

All general processes are a descendant of `init(8)`. By default, `init` has a mask that includes all CPUs in the system and only selected processes with appropriate capabilities can modify their CPU affinity. If it is desired that by default all processes are restricted to a subset of CPUs, a CPU affinity can be assigned by a privileged user to the `init` process. To achieve this goal, the `run(1)` command can be invoked early during the system initialization process.

For example, to bias `init` and all its descendants to CPUs 1, 2 and 3, the following command may be added at the end of the system's `/etc/rc.sysinit` script, which is called early during system initialization (see `inittab(5)`). The `init` process is specified in this command by its process ID which is always 1.

```
/usr/bin/run -b 1-3 -p 1
```

The same effect can be achieved by using the `shield(1)` command. The advantage of using this command is that it can be done from the command line at any run level. The `shield` command will take care of migrating processes already running in the CPU to be shielded. In addition, with the `shield` command you can also specify different levels of shielding. See the section "Shield Command" or the `shield(1)` man page for more information on this command.

For example, to shield CPU 0 from running processes, you would issue the following command.

```
$ shield -p 0
```

After shielding a CPU, you can always specify selected processes to run in the shielded CPU using the `run` command.

For example, to run `mycommand` on CPU 0 which was previously shielded from processes, you would issue the following command:

```
$ run -b 0 ./mycommand
```

Example of Setting Up a Shielded CPU

The following example shows how to use a shielded CPU to guarantee the best possible interrupt response to an edge-triggered interrupt from the RCIM. In other words, the intent is to optimize the time it takes to wake up a user-level process when the edge-triggered interrupt on an RCIM occurs and to provide a deterministic execution environment for that process when it is awakened. In this case the shielded CPU should be set up to handle just the RCIM interrupt and the program responding to that interrupt.

The first step is to direct interrupts away from the shielded processor through the `shield(1)` command. The local timer interrupt will also be disabled and background

processes will be precluded to achieve the best possible interrupt response. The shield command that would accomplish these results for CPU 1 is:

```
$ shield -a 1
```

At this point, there are no interrupts and no processes that are allowed to execute on shielded CPU 1. The shielding status of the CPUs can be checked using the following methods:

via the **shield(1)** command:

```
$ shield -c
CPUID      irqs      ltmrs      procs
-----
      0      no        no         no
      1      yes       yes        yes
      2      no        no         no
      3      no        no         no
```

via the **cpu(1)** command:

```
$ cpu
cpu chip  core ht ht-siblings state shielding
--- ---  --- -- -
0   0    -   0  2          up   none
1   3    -   0  3          up   proc irq ltmr
2   0    -   1  0          up   none
3   3    -   1  1          up   none
```

or via the **/proc** file system:

```
$ cat /proc/shield/irqs
00000002
```

This indicates that all interrupts are precluded from executing on CPU 1. In this example, the goal is to respond to a particular interrupt on the shielded CPU, so it is necessary to direct the RCIM interrupt to CPU 1 and to allow the program that will be responding to this interrupt to run on CPU 1.

The first step is to determine the IRQ to which the RCIM interrupt has been assigned. The assignment between interrupt and IRQ will be constant for devices on the motherboard and for a PCI device in a particular PCI slot. If a PCI board is moved to a new slot, its IRQ assignment may change. To find the IRQ for your device, perform the following command:

```
$ cat /proc/interrupts
          CPU0           CPU1           CPU2           CPU3
0:  665386907             0             0             0   IO-APIC-edge timer
4:           2720             0             0             0   IO-APIC-edge serial
8:             1             0             0             0   IO-APIC-edge rtc
9:             0             0             0             0   IO-APIC-level acpi
14:  9649783             1             2             3   IO-APIC-edge ide0
15:           31             0             0             0   IO-APIC-edge ide1
16:  384130515             0             0             0   IO-APIC-level eth0
17:           0             0             0             0   IO-APIC-level rcim,Intel..
18:  11152391             0             0             0   IO-APIC-level aic7xxx,...
19:           0             0             0             0   IO-APIC-level uhci_hcd
23:           0             0             0             0   IO-APIC-level uhci_hcd
```

```

NMI:  102723410  116948412      0      0  Non-maskable interrupts
LOC:  665262103  665259524  665264914  665262848  Local interrupts
RES:  36855410   86489991   94417799   80848546   Rescheduling interrupts
CAL:    2072      2074      2186      2119      function call interrupts
TLB:   32804     28195     21833     37493     TLB shootdowns
TRM:    0         0         0         0         Thermal event interrupts
SPU:    0         0         0         0         Spurious interrupts
ERR:    0         0         0         0         Error interrupts
MIS:    0         0         0         0         APIC errata fixups

```

The RCIM is assigned to IRQ 17 in the list above. Now that its IRQ number is known, the interrupt for the RCIM can be assigned to the shielded processor via the `/proc` file that represents the affinity mask for IRQ 17. The affinity mask for an IRQ is an 8 digit ASCII hexadecimal value. The value is a bit mask of CPUs. Each bit set in the mask represents a CPU where the interrupt routine for this interrupt may be handled. The radix position of each set bit is the number of a logical CPU that can handle the interrupt. The following command sets the CPU affinity mask for IRQ 17 to CPU 1:

```
$ echo 2 > /proc/irq/17/smp_affinity
```

Note that the “`smp_affinity`” file for IRQs is installed by default with permissions such that only the root user can change the interrupt assignment of an IRQ. The `/proc` file for IRQ affinity can also be read to be sure that the change has taken effect:

```
$ cat /proc/irq/17/smp_affinity
00000002 user 00000002 actual
```

Note that the value returned for “user” is the bit mask that was specified by the user for the IRQ’s CPU affinity. The value returned for “actual” will be the resulting affinity after any non-existent CPUs and shielded CPUs have been removed from the mask. Note that shielded CPUs will only be stripped from an IRQ’s affinity mask if the user set an affinity mask that contained both shielded and non-shielded CPUs. This is because a CPU shielded from interrupts will only handle an interrupt if there are no unshielded CPUs in the IRQ’s affinity mask that could handle the interrupt. In this example, CPU 1 is shielded from interrupts, but CPU 1 will handle IRQ 17 because its affinity mask specifies that only CPU 1 is allowed to handle the interrupt.

The next step is to be sure that the program responding to the RCIM edge-triggered interrupt will run on the shielded processor. Each process in the system has an assigned CPU affinity mask. For a CPU shielded from background processes, only a process that has a CPU affinity mask which specifies ONLY shielded CPUs will be allowed to run on a shielded processor. Note that if there are any non-shielded CPUs in a process’ affinity mask, then the process will only execute on the non-shielded CPUs.

The following command will execute the user program “edge-handler” at a real-time priority and force it to run on CPU 1:

```
$ run -s fifo -P 50 -b 1 edge-handler
```

Note that the program could also set its own CPU affinity by calling the library routine `mpadvise(3)` as described in the section “Multiprocessor Control Using `mpadvise`.”

The `run(1)` command can be used to check the program’s affinity:

```
$ run -i -n edge-handler
Pid  Tid  Bias  Actual  Policy  Pri  Nice  Name
9326 9326 0x2   0x2     fifo    50   0     edge-handler
```

Note that the value returned for “Bias” is the bit mask that was specified by the user for the process' CPU affinity. The value returned for “actual” will be the resulting affinity after any non-existent CPUs and shielded CPUs have been removed from the mask. Note that shielded CPUs will only be stripped from a process' affinity mask if the user set an affinity mask that contained both shielded and non-shielded CPUs. This is because a CPU shielded from background processes will only handle a process if there are no unshielded CPUs in the process' affinity mask that could run the program. In this example, CPU 1 is shielded from background processes, but CPU 1 will run the “edge-handler” program because its affinity mask specifies that only CPU 1 is allowed to run this program.

Procedures for Increasing Determinism

The following sections explain various ways in which you can improve performance using the following techniques:

- locking a process' pages in memory
- using favorable static priority assignments
- removing non-critical processing from interrupt level
- speedy wakeup of processes
- controlling cache access
- reserving physical memory
- in a NUMA system, binding a program to local memory
- judicious use of hyper-threading
- avoiding a low memory state

Locking Pages in Memory

You can avoid the overhead associated with paging and swapping by using **mlockall(2)**, **munlockall(2)**, **mlock(2)**, and **munlock(2)**. These system calls allow you to lock and unlock all or a portion of a process' virtual address space in physical memory. These interfaces are based on IEEE Standard 1003.1b-1993.

With each of these calls, pages that are not resident at the time of the call are faulted into memory and locked. To use the **mlockall(2)**, **munlockall(2)**, **mlock(2)**, and **munlock(2)** system calls you must have the **CAP_IPC_LOCK** and **CAP_SYS_RAWIO** capabilities (for additional information on capabilities, refer to Chapter 13 and the **pam_capability(8)** man page.

Procedures for using these system calls are fully explained in the corresponding man pages.

Setting the Program Priority

The RedHawk Linux kernel accommodates static priority scheduling—that is, processes scheduled under certain POSIX scheduling policies do not have their priorities changed by the operating system in response to their run-time behavior.

Processes that are scheduled under one of the POSIX real-time scheduling policies always have static priorities. (The real-time scheduling policies are **SCHED_RR** and **SCHED_FIFO**; they are explained Chapter 4.) To change a process' scheduling priority, you may use the

sched_setscheduler(2) and the **sched_setparam(2)** system calls. Note that to use these system calls to change the priority of a process to a higher (more favorable) value, you must have the `CAP_SYS_NICE` capability (for complete information on capability requirements for using these routines, refer to the corresponding man pages).

The highest priority process running on a particular CPU will have the best process dispatch latency. If a process is not assigned a higher priority than other processes running on a CPU, its process dispatch latency will be affected by the time that the higher priority processes spend running. As a result, if you have more than one process that requires good process dispatch latency, it is recommended that you distribute those processes among several CPUs. Refer to the section “Assigning Processes to CPUs,” for the procedures for assigning processes to particular CPUs.

Process scheduling is fully described in Chapter 4. Procedures for using the **sched_setscheduler** and **sched_setparam** system calls to change a process’ priority are also explained.

Setting the Priority of Deferred Interrupt Processing

Linux supports several mechanisms that are used by interrupt routines in order to defer processing that would otherwise have been done at interrupt level. The processing required to handle a device interrupt is split into two parts. The first part executes at interrupt level and handles only the most critical aspects of interrupt completion processing. The second part is deferred to run at program level. By removing non-critical processing from interrupt level, the system can achieve better interrupt response time as described earlier in this chapter in the section “Effect of Interrupts.”

The second part of an interrupt routine can be handled by kernel daemons, depending on which deferred interrupt technique is used by the device driver. There are kernel tunables that allow a system administrator to set the priority of the kernel daemons that handle deferred interrupt processing. When a real-time task executes on a CPU that is handling deferred interrupts, it is possible to set the priority of the deferred interrupt kernel daemon so that a high-priority user process has a more favorable priority than the deferred interrupt kernel daemon. This allows more deterministic response time for this real-time process.

For more information on deferred interrupt processing, including the daemons used and kernel tunables for setting their priorities, see the chapter “Device Drivers.”

Waking Another Process

In multiprocess applications, you often need to wake a process to perform a particular task. One measure of the system’s responsiveness is the speed with which one process can wake another process. The fastest method you can use to perform this switch to another task is to use the **postwait(2)** system call. For compatibility with legacy code, the **server_block(2)** and **server_wake1(2)** functions are provided in RedHawk Linux.

Procedures for using these functions are explained in Chapter 5 of this guide.

Avoiding Cache Thrashing

Application writers trying to approach ‘constant runtime determinism’ must pay attention to how their program’s variables will be mapped into the CPU’s caches. For example, if a program has a variable *i* and a variable *j* and both are heavily used, and the memory locations assigned to them result in both *i* and *j* being in the same cache line, every reference to *i* will eject *j* from the cache and vice versa. This is called thrashing the cache and its occurrence is devastating to performance.

To avoid this, place all heavily accessed data close to one another in memory. If that range is smaller than the cache size, all the data will be guaranteed different cache lines. To view how large the CPU’s cache is, execute “`grep cache /proc/cpuinfo`”.

Make sure that your system has cache that is larger than the data set of heavily accessed variables. For example, if you have 600,000 bytes of variables and you have a system with only .5 MB of cache, cache thrashing will be unavoidable.

If you have less than one page (4096 bytes) of critical variables, then you can force them to be in separate cache lines by forcing all the data to be in one physical page:

```
struct mydata{
    int i;
    int j;
    float fp[200];
    float fq[200]; } __attribute__((__aligned__(4096)));

struct mydata mydata;
```

Reserving Physical Memory

Physical memory can be reserved through the use of command line arguments in the `/etc/grub.conf` file.

This type of allocation may be used for a DMA buffer required by a local device or for a device on a foreign host that is mapped to iHawk memory, such as through a PCI-to-VME adapter. It can also be used to provide a data space that does not have the randomness of page allocations from dynamic virtual memory allocations. This could enhance application performance by making cache collisions of large data arrays more constant, thus reducing variance in execution times from sequential invocations of a process.

By custom mapping memory in the `grub.conf` file, a “reserved” section of RAM can be obtained. The System V `shmop(2)` function can be used to access this region of physical memory. `Shmconfig(1)` or `shmbind(2)`, and `shmop(2)` functions can be used to create and attach to this memory partition.

The amount of physical RAM available can be viewed by examining the contents of `/proc/iomem`, as shown below on an i386 system.

```

$ cat /proc/iomem
00000000-0009ffff : System RAM
    00000000-00000000 : Crash kernel
000a0000-000bffff : Video RAM area
000c0000-000cefff : Video ROM
000d0800-000d3fff : Adapter ROM
000f0000-000fffff : System ROM
00100000-7fe8abff : System RAM
    00100000-004f58a5 : Kernel code
    004f58a6-00698577 : Kernel data
7fe8ac00-7fe8cbff : ACPI Non-volatile Storage
7fe8cc00-7fe8ebff : ACPI Tables
7fe8ec00-7fffffff : reserved
    :
(I/O entries removed from example)

```

The regions marked “System RAM” represent the available physical memory for allocation.

An example of `/etc/grub.conf` that illustrates how to reserve physical RAM is shown below in hexadecimal (an example in decimal follows). The commands placed in `grub.conf` are processed at boot time to create the memory mapping.

The “`memmap=exactmap`” entry specifies that the exact BIOS map is used.

The remaining entries specify regions to be defined. The command format is:

```
memmap=size<op>address
```

where `<op>` is ‘@’ for System RAM, ‘\$’ for Reserve or “#” for ACPI.

The following example reserves 32MB just below the address of 1G:

```

default=0
timeout=10
splashimage=(hd0,0)/grub/ccur.xpm.gz
title RedHawk Linux 2.3 (Trace=Yes, Debug=No)
    root (hd0,0)
    kernel /vmlinuz-2.6.9-RedHawk-2.3-trace ro root=/dev/sda2 vmlloc=256M \
    memmap=exactmap \
    memmap=0xa0000@0x0 \
    memmap=0x3df0000@0x100000 \
    memmap=0x200000$0x3e000000 \
    memmap=0x3fe8ac00@0x40000000 \
    memmap=0x2000#0x7fe8cc00

```

It should be noted that the grub command line is limited to 256 bytes. The addition of parameters to the grub command line must not exceed this limit.

The entries shown above are obtained using the `memexact (1)` utility and subsequently copied to the `/etc/grub.conf` command line. `Memexact` processes command options and produces appropriate memory reservation commands based on the contents of `/proc/iomem` or a file specified on the command line.

```
# /usr/bin/memexact -x -MS=32M,U=1G
memmap=exactmap memmap=0xa0000@0 memmap=0x3df00000@0x100000 memmap=0xa0000@0
memmap=0x3df00000@0x100000 memmap=0x2000000$0x3e000000
memmap=0x3fe8ac00@0x40000000 memmap=0x2000#0x7fe8cc00
```

where:

-x	specifies hexadecimal output
-M	multiple entries may follow
-S	specifies the reservation size
-U	specifies the upper limit of the reservation

This reserved region can be arbitrarily selected as long as the location is from memory identified as “System RAM” in the `/proc/iomem` listing and does not include the kernel addresses. The regions “Adapter ROM,” “System ROM,” “ACP,” and “reserved” must not be re-mapped using these commands. **Memexact (1)** selects the appropriate locations to reserve based on the contents of `/proc/iomem` and the command line options presented.

CAUTION

Errors made in these entries, such as overlapping previously reserved regions (e.g. System ROM, etc.), can cause fatal errors booting the kernel.

The following example uses decimal address. It is identical in function to the example in hexadecimal above and produces identical results.

```
# memexact -MS=32M,U=1G
memmap=exactmap memmap=640K@0 memmap=991M@1M memmap=32M$992M
memmap=1047083K@1G memmap=8K#2095667K
```

Below is the corresponding **grub.conf** file with these added decimal entries:

```
default=0
timeout=10
splashimage=(hd0,0)/grub/ccur.xpm.gz
title RedHawk Linux 2.3(Trace=Yes, Debug=No)
    root (hd0,0)
    kernel /vmlinuz-2.6.9-RedHawk-2.3-trace ro root=/dev/sda2 vmlloc=256M \
    memmap=exactmap \
    memmap=640K@0 \
    memmap=991M@1M \
    memmap=32M$992M \
    memmap=1047083K@1G \
    memmap=8K#2095667K
```

Below is a comparison of memory before and after the reservation made in the examples above. The “after reservation” region at 0x3e000000 marked “reserved” is the newly-reserved 32 MB region.

/proc/iomem before reservation	/proc/iomem after reservation
<pre>00000000-0009ffff : System RAM 00000000-00000000 : Crash kernel 000a0000-000bffff : Video RAM area 000c0000-000cefff : Video ROM 000d0800-000d3fff : Adapter ROM 000f0000-000fffff : System ROM 00100000-7fe8abff : System RAM 00100000-004f58a5 : Kernel code 004f58a6-00698577 : Kernel data 7fe8ac00-7fe8cbff : ACPI Non-volatile Storage 7fe8cc00-7fe8ebff : ACPI Tables 7fe8ec00-7fffffff : reserved . .</pre>	<pre>00000000-0009ffff : System RAM 00000000-00000000 : Crash kernel 000a0000-000bffff : Video RAM area 000c0000-000cefff : Video ROM 000d0800-000d3fff : Adapter ROM 000f0000-000fffff : System ROM 00100000-3dffffff : System RAM 00100000-004f58a5 : Kernel code 004f58a6-00698577 : Kernel data 3e000000-3fffffff : reserved 40000000-7fe8abff : System RAM 7fe8cc00-7fe8ebff : ACPI Tables . .</pre>
(I/O entries removed from example)	

The next example illustrates the commands placed in **grub.conf** to reserve a memory region between two system RAM regions beyond 4 GB on an x86_64 system. The **/proc/iomem** output before this reservation is shown on the next page.

Note that on x86_64 systems, “mm” is an alias for “memmap” and “ex” is an alias for “exactmap.” These shorter alias names should be used in order to reduce the number of characters required to set up a reserved area, since there is a limit of 256 characters per grub command line.

```
mm=ex \
mm=0x9fc00@0x0 \
mm=0x400@0x9fc00 \
mm=0x20000$0xe0000 \
mm=0xcfef0000@0x100000 \
mm=0x10000#0xcfff0000 \
mm=0x840000$0xff7c0000 \
mm=512M@0x100000000 \
mm=512M$4608M \
mm=1G@5G
```

Below is a comparison of memory before and after the reservation made in the example above. The “after reservation” region at 0x0000000120000000 marked “reserved” is the newly-reserved region.

/proc/iomem before reservation	/proc/iomem after reservation
<pre>0000000000000000-000000000009fbff : System RAM 000000000009fc00-000000000009ffff : reserved 00000000000a0000-00000000000bffff : Video RAM area 00000000000c0000-00000000000c7fff : Video ROM 00000000000c8000-00000000000cbfff : Adapter ROM 00000000000f0000-00000000000fffff : System ROM 000000000100000-00000000d7feffff : System RAM</pre>	<pre>0000000000000000-000000000009fbff : System RAM 000000000009fc00-000000000009ffff : System RAM 00000000000a0000-00000000000bffff : Video RAM area 00000000000c0000-00000000000c7fff : Video ROM 00000000000c8000-00000000000cbfff : Adapter ROM 00000000000f0000-00000000000fffff : System ROM 000000000100000-00000000cffeffff : System RAM</pre>

<code>/proc/iomem</code> before reservation	<code>/proc/iomem</code> after reservation
0000000000100000-000000000005c9521 : Kernel code	0000000000100000-000000000005c9521 : Kernel code
000000000005c9522-00000000000954137 : Kernel data	000000000005c9522-00000000000954137 : Kernel data
00000000d7fff0000-00000000d7ffff : ACPI Tables	00000000cfff0000-00000000cfffffff : ACPI Tables
00000000d7fff000-00000000d7ffff : ACPI Non-volatile Storage	00000000ff7c0000-00000000fffffff : reserved
00000000ff7c0000-00000000fffffff : reserved	0000000100000000-000000011fffffff : System RAM
0000000100000000-000000017fffffff : System RAM	0000000120000000-000000013fffffff : reserved
.	0000000140000000-000000017fffffff : System RAM
.	.
.	.

(I/O entries removed from example)

Shmconfig(1) or **shmbind(2)** can be used to create a partition at the reserved physical address. The System V shared memory operations **shmop(2)** can be used by an application to gain access to the region.

The following example, based on the first example given in this section on an i386 system, creates a System V memory partition of 32MB at physical address 0x3e000000 with unrestricted access and a key of 6602:

```
# usr/bin/shmconfig -s 0x2000000 -p 0x3e000000 -m 0777 6602
```

This command may be placed in `/etc/rc.local` to automate the creation of the shared memory partition. While this example uses a hard coded key of 6602, use of a pathname such as `/dev/MyDevice` as a key allows applications to obtain the key to be used for attachment using the **ftok(3)** function.

The following code fragment could also be used to dynamically create the shared memory partition.

```
.
.
paddr = 0x3e000000 ;
shmkey = ftok( pathname ) ;
shmid = shmget ( shmkey, sizeof ( <shared_region> ) ,
                SHM_R | SHM_W | IPC_CREAT ) ;
shmstat = shmbind ( shmid , paddr ) ;
pstart = shmat ( shmid , NULL , SHM_RND ) ;
.
.
```

The shared memory segments on the system are visible using **ipcs(8)** (-m option) or via the `/proc/sysvipc/shm` file.

```
# cat /proc/sysvipc/shm
  key shmid      perms      size  cpid  lpid  nattch  uid  gid  cuid  cgid
  atime dtime      ctime physaddr
  6602   0         777  33554432  4349   0     0     0   0   0   0
    0     0 1153750799 3e000000
```

```
# ipcs -m
```

```

----- Shared Memory Segments -----
      key      shmid   owner    perms    bytes    nattach  status
0x000019ca      0     root      777   33554432      0

```

Refer to the man pages or Chapter 3 for more information about using these functions and utilities.

Binding to NUMA Nodes

On a system with non-uniform memory access (NUMA), such as an iHawk Opteron system, it takes longer to access some regions of memory than others. The memory on a NUMA system is divided into nodes, where a node is defined to be a region of memory and all CPUs that reside on the same physical bus as the memory region of the NUMA node. If a program running on this type of system is not NUMA-aware, it can perform poorly.

By default, pages are allocated from the node where the local CPU (from which the program is executed) resides, but the task or virtual areas within the task can be specified to allocate pages from certain nodes for better determinism and control. Refer to Chapter 10 for information about NUMA.

I/O Throughput on Quad Opteron Systems

In a quad Opteron symmetric multiprocessor system, every processor has a unique bank of memory attached directly to the processor. All memory in the system can be accessed from any processor via the HyperTransport™, but the memory that is directly attached to a processor is the memory that will have the fastest access time for that thread of execution running on that processor. This layout is illustrated in Figure 2-7.

Figure 2-7 Quad Opteron I/O Throughput Layout

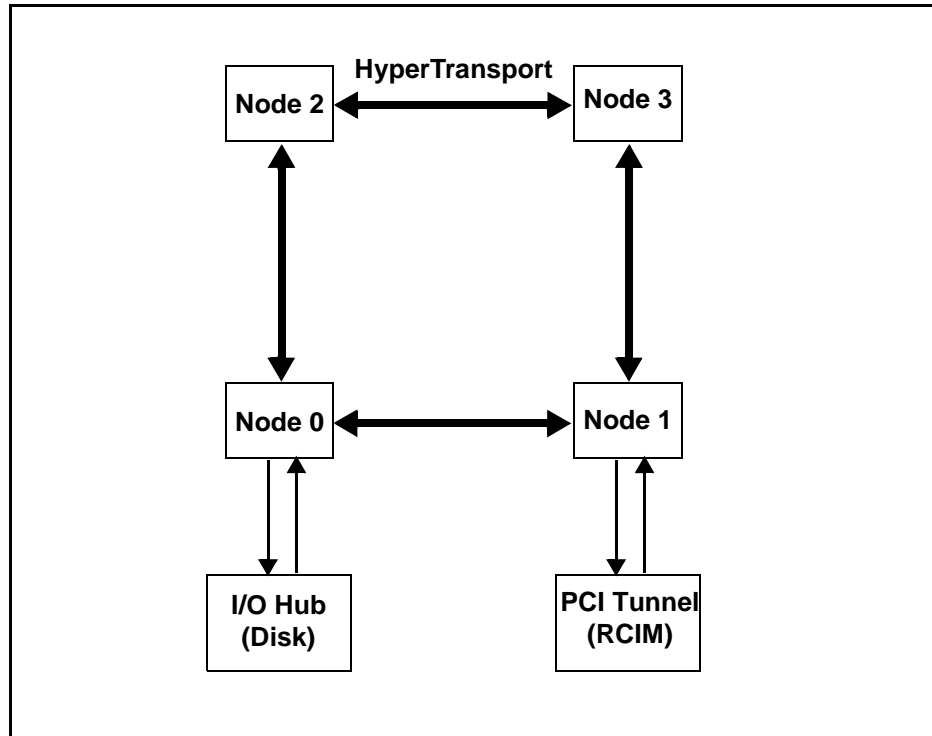

Access to I/O devices in an Opteron system is likewise not completely symmetrical. The I/O hub and the PCI tunnel are directly attached to a specific node in the system. In Figure 2-7, the I/O hub is attached to Node 0 and the PCI tunnel is attached to Node 1. Testing has shown that programmed I/O times are both faster and more deterministic when the program performing the programmed I/O is running on the node attached to the I/O bus where the device resides. The effect on I/O performance is especially noticeable when there is contention for the HyperTransport interconnects because other programs are performing I/O or non-local memory operations.

This means that if an application demands high speed deterministic programmed I/O, the program performing such I/O should be bound to run on the processor closest to the I/O bus where the device resides.

The node that is tied to the I/O bridge can be determined either by looking at system schematics or by testing.

Understanding Hyper-threading

Hyper-threading is a feature of the Intel Pentium Xeon processor in iHawk 860 systems. It allows for a single physical processor to run multiple threads of software applications simultaneously. This is achieved by having two sets of architectural state on each processor while sharing one set of processor execution resources. The architectural state tracks the flow of a program or thread, and the execution resources are the units on the

processor that do the work: add, multiply, load, etc. Each of the two sets of architectural state in a hyper-threaded physical CPU can be thought of as a “logical” CPU. The term “sibling CPU” refers to the other CPU in a pair of logical CPUs that reside on the same physical CPU.

When scheduling threads, the operating system treats the two logical CPUs on a physical CPU as if they were separate processors. Commands like `ps(1)` or `shield(1)` identify each logical CPU. This allows multiprocessor-capable software to run unmodified on twice as many logical processors. While hyper-threading technology does not provide the level of performance scaling achieved by adding a second physical processor, some benchmark tests show that parallel applications can experience as much as a 30 percent gain in performance. See the section “Recommended CPU Configurations” for ideas on how to best utilize hyper-threading for real-time applications.

The performance gain from hyper-threading occurs because one processor with two logical CPUs can more efficiently utilize execution resources. During normal program operation on a non-hyper-threaded CPU, execution resources on the chip often sit idle awaiting input. Because the two logical CPUs share one set of execution resources, the thread executing on the second logical CPU can use resources that are otherwise idle with only one thread executing. For example while one logical CPU is stalled waiting for a fetch from memory to complete, its sibling can continue processing its instruction stream. Because the speeds of the processor and the memory bus are very unequal, a processor can spend a significant portion of its time waiting for data to be delivered from memory. Thus, for certain parallel applications hyper-threading provides a significant performance improvement. Another example of parallelism is one logical processor executing a floating-point operation while the other executes an addition and a load operation. These operations execute in parallel because they utilize different processor execution units on the chip.

While hyper-threading will generally provide faster execution for a multi-thread workload, it can be problematic for real-time applications. This is because of the impact on the determinism of execution of a thread. Because a hyper-threaded CPU shares the execution unit of the processor with another thread, the execution unit itself becomes another level of resource contention when a thread executes on a hyper-threaded CPU. Because the execution unit will not always be available when a high priority process on a hyper-threaded CPU attempts to execute an instruction, the amount of time it takes to execute a code segment on a hyper-threaded CPU is not as predictable as on a non-hyper-threaded CPU.

The designer of a parallel real-time application should decide whether hyper-threading makes sense for his application. Will the application benefit from its tasks running in parallel on a hyper-threaded CPU as compared to running sequentially? If so, the developer can make measurements to determine how much jitter is introduced into the execution speeds of important high-priority threads by running them on a hyper-threaded CPU.

The level of jitter that is acceptable is highly application dependent. If an unacceptable amount of jitter is introduced into a real-time application because of hyper-threading, then the affected task should be run on a shielded CPU with its sibling CPU marked down (idled) via the `cpu(1)` command. An example of a system with a CPU marked down is given later in this chapter. It should be noted that certain cross processor interrupts will still be handled on a downed CPU (see the `cpu(1)` man page for more information). If desired, hyper-threading can be disabled on a system-wide basis. See the section “System Configuration” below for details.

Hyper-threading technology is complementary to multiprocessing by offering greater parallelism within each processor in the system, but is not a replacement for dual or multiprocessing. There are twice as many logical processors available to the system, however, they are still sharing the same amount of execution resources. So the performance benefit of another physical processor with its own set of dedicated execution resources will offer greater performance levels. This can be especially true for applications that are using shielded CPUs for obtaining a deterministic execution environment.

As mentioned above, each logical CPU maintains a complete set of the architecture state. The architecture state (which is *not* shared by the sibling CPUs) consists of general-purpose registers, control registers, advanced programmable interrupt controller (APIC) registers and some machine state registers. Logical processors share nearly all other resources on the physical processor such as caches, execution units, branch predictors, control logic, and buses. Each logical processor has its own interrupt controller or APIC. Interrupts sent to a specific logical CPU are handled only by that logical CPU, regardless of whether hyper-threading is enabled or disabled.

System Configuration

The following items affect system-wide hyper-thread availability:

- The system must contain Intel Pentium Xeon processors.
- The kernel must be configured with hyper-threading enabled through the X86_HT kernel tunable accessible under Processor Type and Features on the Kernel Configuration GUI. Hyper-threading is enabled by default on all RedHawk i386 pre-defined kernels.
- Hyper-threading must be enabled in the BIOS to be available for use. Refer to your hardware documentation to determine which BIOS setting is involved, if needed.

Hyper-threading can be disabled on a per-CPU basis using the `cpu (1)` command to mark one of the siblings down. Refer to the `cpu (1)` man page for more details.

Note that with hyper-threading enabled, commands like `top (1)` and `run (1)` report twice as many CPUs as were previously present on systems running a version of RedHawk Linux prior to release 1.3 that did not have hyper-threading support. When hyper-threading is disabled on a system-wide basis, the logical CPU numbers are equivalent to the physical CPU numbers.

Recommended CPU Configurations

Hyper-threading technology offers the possibility of better performance for parallel applications. However, because of the manner in which CPU resources are shared between the logical CPUs on a single physical CPU, different application mixes will have varied performance results. This is especially true when an application has real-time requirements requiring deterministic execution times for the application. Therefore, it is important to test the performance of the application under various CPU configurations to determine optimal performance. For example, if there are two tasks that could be run in parallel on a pair of sibling CPUs, be sure to compare the time it takes to execute these tasks in parallel using both siblings versus the time it takes to execute these tasks serially with one of the siblings down. This will determine whether these two tasks can take advantage of the unique kind of parallelism provided by hyper-threading.

Below are suggested ways of configuring an SMP system that contains hyper-threaded CPUs for real-time applications. These examples contain hints about configurations that might work best for applications with various performance characteristics.

Standard Shielded CPU Model

This model would be used by applications having very strict requirements for determinism in program execution. A shielded CPU provides the most deterministic environment for these types of tasks (see the section “How Shielding Improves Real-Time Performance” for more information on shielded CPUs). In order to maximize the determinism of a shielded CPU, hyper-threading on that physical CPU is disabled. This is accomplished by marking down the shielded CPU’s sibling logical CPU using the `cpu(1)` command.

In the Standard Shielded CPU Model, the non-shielded CPUs have hyper-threading enabled. These CPUs are used for a non-critical workload because in general hyper-threading allows more CPU resources to be applied.

Figure 2-8 illustrates the Standard Shielded CPU Model on a system that has two physical CPUs (four logical CPUs). In this example, CPU 3 has been taken down and CPU 2 is shielded from interrupts, processes and hyper-threading. A high priority interrupt and the program responding to that interrupt would be assigned to CPU 2 for the most deterministic response to that interrupt.

Figure 2-8 The Standard Shielded CPU Model

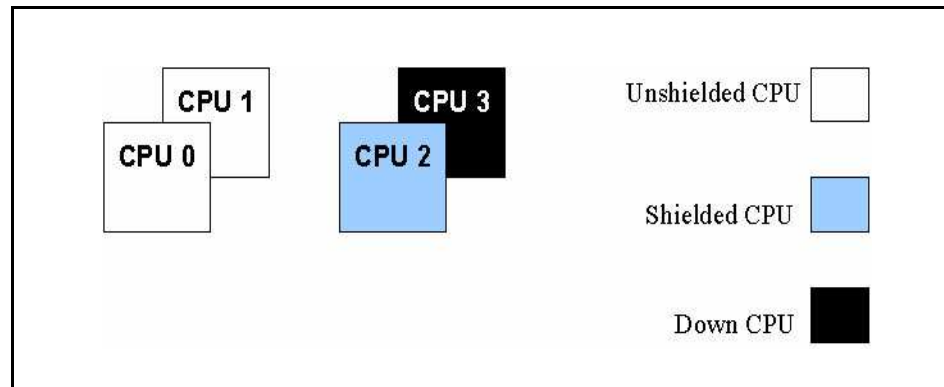

The commands to set up this configuration are:

```
$ shield -a 2
$ cpu -d 3
```

Shielding with Interrupt Isolation

This model is very similar to the Standard Shielded CPU Model. However, in this case all logical CPUs are used, none are taken down. Like the Standard Shielded CPU Model, a subset of the logical CPUs is shielded. But rather than taking down the siblings of the shielded CPUs, those CPUs are also shielded and are dedicated to handling high priority interrupts that require deterministic interrupt response. This is accomplished by shielding the sibling CPUs from processes and interrupts and then setting the CPU affinity of a

particular interrupt to that sibling CPU. Shielding with interrupt isolation is illustrated in Figure 2-9.

Figure 2-9 Shielding with Interrupt Isolation

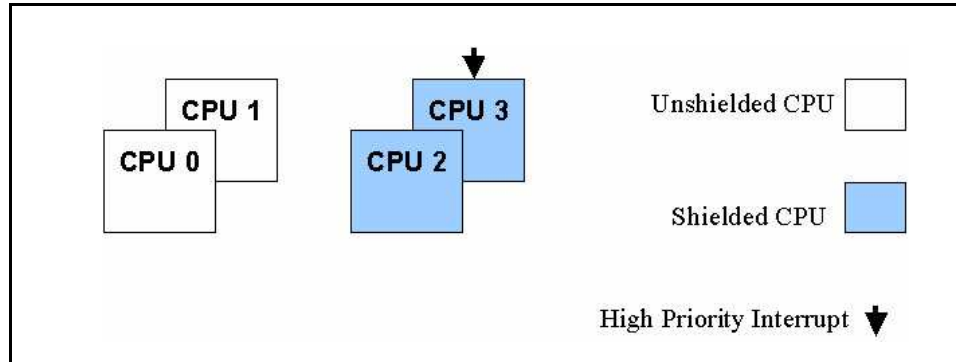

The benefit of this approach is that it provides a small amount of parallelism between the interrupt routine (which runs on CPU 3) and execution of high priority tasks on the sibling CPU (the program awaiting the interrupt runs on CPU 2). Because the interrupt routine is the only code executing on CPU 3, this interrupt routine will generally be held in the L1 cache in its entirety, and the code will stay in the cache, providing optimum execution times for the interrupt routine. There is a small penalty to pay however, because the interrupt routine must send a cross processor interrupt in order to wake the task that is awaiting this interrupt on the sibling CPU. This additional overhead has been measured at less than two microseconds.

Another potential use of using shielding with interrupt isolation is to improve I/O throughput for a device. Because we are dedicating a CPU to handling a device interrupt, this interrupt will always complete as quickly as possible when an I/O operation has completed. This allows the interrupt routine to immediately initiate the next I/O operation, providing better I/O throughput.

Hyper-thread Shielding

This configuration is another variation of the Standard Shielded CPU Model. In this case, one sibling is shielded while the other sibling is allowed to run general tasks. The shielded CPU will have its determinism impacted by the activity on its sibling CPU. However, the advantage is that much more of the CPU power of this physical CPU can be utilized by the application. Figure 2-10 illustrates a Hyper-thread Shielding configuration.

Figure 2-10 Hyper-thread Shielding

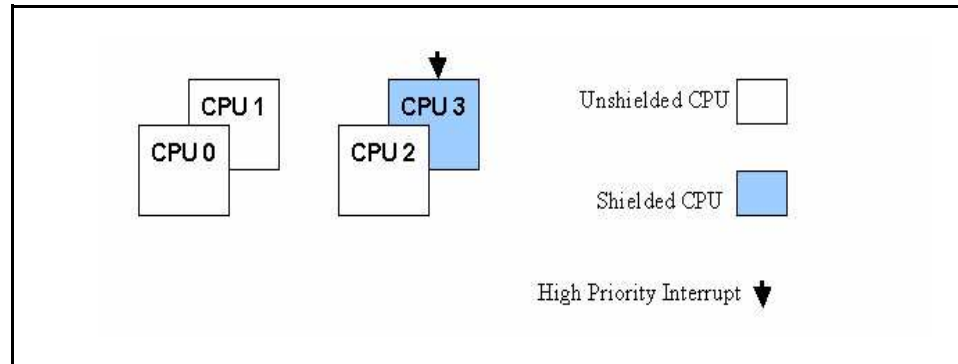

In this example, CPU 3 is shielded and allowed to run only a high priority interrupt and the program that responds to that interrupt. CPU 2 is either not shielded and therefore available for general use or is set up to run a specific set of tasks. The tasks that run on CPU 2 will not directly impact interrupt response time, because when they disable preemption or block interrupts there is no effect on the high priority interrupt or task running on CPU 3. However, at the chip resource level there is contention that will impact the determinism of execution on CPU 3. The amount of impact is very application dependent.

Floating-point / Integer Sharing

This configuration can be used when the application has some programs that primarily perform floating-point operations and some programs that primarily perform integer arithmetic operations. Both siblings of a hyper-threaded CPU are used to run specific tasks. Programs that are floating-point intensive are assigned to one sibling CPU and programs that primarily execute integer operations are assigned to the other sibling CPU. The benefit of this configuration is that floating-point operations and integer operations use different chip resources. This allows the application to make good use of hyper-thread style parallelism because there is more parallelism that can be exploited at the chip level. It should also be noted that applications on the CPU that are only performing integer operations would see faster context switch times because there won't be save/restore of the floating-point registers during the context switch.

Shared Data Cache

This configuration can be used when the application is a producer/consumer style of application. In other words, one process (the consumer) is operating on data that has been passed from another process (the producer). In this case, the producer and consumer threads should be assigned to the siblings of a hyper-threaded CPU. Because the two sibling CPUs share the data cache, it is likely that the data produced by the producer process is still in the data cache when the consumer process accesses the data that has been passed from the producer task. Using two sibling CPUs in this manner allows the producer and consumer tasks to operate in parallel, and the data passed between them is essentially passed via the high-speed cache memory. This offers significant opportunity for exploiting hyper-thread style parallelism.

Another potential use of this model is for the process on one sibling CPU to pre-fetch data into the data cache for a process running on the other sibling on a hyper-threaded CPU.

Shielded Uniprocessor

This configuration is a variation of the Hyper-thread Shielding configuration. The only difference is that we are applying this technique to a uniprocessor rather than to one physical CPU in an SMP system. Because a physical CPU now contains two logical CPUs, a uniprocessor can now be used to create a shielded CPU. In this case, one of the CPUs is marked shielded while the other CPU is used to run background activity. Determinism on this type of shielded CPU will not be as solid as using CPU shielding on a distinct physical CPU, but it will be significantly better than with no shielding at all.

Avoiding a Low Memory State

Ensure that your system has adequate physical RAM. Concurrent's real-time guarantees assume a properly configured system with adequate RAM for real-time application usage. In low-memory situations, real-time deadlines may be sacrificed to better ensure system integrity and maintain proper system behavior. When Linux runs out of memory, it randomly selects processes to kill in an attempt to free up memory so that other processes can proceed.

Memory usage can be monitored using a number of tools including `/proc/meminfo`, `free(1)` and `vmstat(8)`.

Known Issues with Linux Determinism

The following are issues with standard Linux that are known to have a negative impact on real-time performance. These actions are generally administrative in nature and should not be performed while the system is executing a real-time application.

- The `hdparm(1)` utility is a command line interface for enabling special parameters for IDE and SCSI disks. This utility is known to disable interrupts for very lengthy periods of time.
- The `blkdev_close(2)` interface is used by BootLoaders to write to the raw block device. This is known to disable interrupts for very lengthy periods of time.
- Avoid scrolling the frame-buffer (fb) console. This is known to disable interrupts for very lengthy periods of time.
- When using virtual consoles, don't switch consoles. This is known to disable interrupts for very lengthy periods of time.
- Avoid mounting and unmounting CDs and unmounting file systems. These actions produce long latencies.
- Turn off auto-mount of CDs. This is a polling interface and the periodic poll introduces long latencies.
- The `haldaemon` service has been shown to interfere with real-time performance and is turned off by default. However, it must be running in

order to burn a file (e.g. iso) onto a CD or DVD from the context menu of the file. To burn a file onto disc, first start the **haldaemon** service:

```
$ service haldaemon start
```

After the copying process is complete, stop the service:

```
$ service haldaemon stop
```

- By default the Linux kernel locks the Big Kernel Lock (BKL) before calling a device driver's **ioctl()** routine. This can cause delays when the **ioctl()** routine is called by a real-time process or is called on a shielded CPU. See the “Device Drivers” chapter for more information on how to correct this problem.
- Avoid unloading kernel modules. This action creates and destroys a number of per-CPU **kmodule** daemons that can add unnecessary jitter on the CPU.
- The IP route cache table, which is flushed periodically by the **ksoftirqd** kernel daemon, is sized dynamically based on the amount of available memory; for example, 128K entries for a system with 4 GB of memory. The time required for the flush can be problematic if network determinism is at issue, especially in a single CPU system. To reduce excessive **ksoftirqd** runs, the IP route cache table can be set to a fixed size using the grub command **rhash_entries=n**, where *n* is the number of table entries; i.e., **rhash_entries=4096** for 4K entries.
- There may be possible real-time issues when starting and stopping the X server while running time-critical applications on shielded CPU(s). Depending upon the type of graphics cards your system uses, this may result in numerous cross-processor interrupts that slow performance. If you are experiencing this, refer to Appendix G for methods to reduce these interrupts.
- Ensure that **DETECT_SOFTLOCKUP** is not present in the kernel. This option interferes with CPU shielding by firing excessive per-CPU daemons on all CPUs, and with rescheduling variables since holding a rescheduling variable is erroneously interpreted by the softlockup machinery as a soft lockup.
- Ensure that **SCHED_SMT_IDLE** is not set in the kernel. This parameter prevents forcing idle one thread of an SMT CPU pair if it is scheduled to run a **SCHED_OTHER** task while the other thread is running a **SCHED_RR** or **SCHED_FIFO** task.
- It is recommended that the **mount(1)** option **noatime** be specified in **/etc/fstab** to eliminate unnecessary updates to inode access time each time the file system is accessed.

Real-Time Interprocess Communication

This chapter describes RedHawk Linux support for real-time interprocess communication through POSIX and System V message passing and shared memory facilities.

Appendix A contains example programs that illustrate the use of the POSIX and System V message queue facilities.

Overview

RedHawk Linux provides several mechanisms that allow processes to exchange data. These mechanisms include message queues, shared memory and semaphores based on the IEEE Standard 1003.1b-1993 as well as those included in the System V Interprocess Communication (IPC) package. Message queues and shared memory are discussed in this chapter; semaphores are discussed in Chapter 5, Interprocess Synchronization.

Message queues allow one or more processes to write messages to be read by one or more reading processes. Facilities are provided to create, open, query and destroy a message queue, send and receive messages from a message queue, associate a priority with a message to be sent, and request asynchronous notification when a message arrives.

POSIX and System V messaging functionality operate independent of each other. The recommended message-passing mechanism is the POSIX message queue facility because of its efficiency and portability. The sections “POSIX Message Queues” and “System V Messages” in this chapter describe these facilities.

Shared memory allows cooperating processes to share data through a common area of memory. One or more processes can attach a segment of memory and as a consequence can share whatever data is placed there.

As with messaging, POSIX and System V shared memory functionality operate independent of each other. It is recommended that you use a System V shared memory area in an application in which data placed in shared memory are temporary and do not need to exist following a reboot of the system. Data in a System V shared memory area are kept only in memory. No disk file is associated with that memory and therefore no disk traffic is generated by the **sync(2)** system call. Also, System V shared memory allows you to bind a shared memory segment to a section of physical I/O memory. Refer to the section “System V Shared Memory” for information about this facility.

An alternative to using System V shared memory is to use the **mmap(2)** system call to map a portion of the **/dev/mem** file. For information on the **mmap** system call, refer to Chapter 9, “Memory Mapping.” For information on the **/dev/mem** file, refer to the **mem(4)** man page.

POSIX shared memory interfaces are mapped to a disk file in the **/var/tmp** directory. If this directory is mounted on a **memfs** file system, then no extra disk traffic is generated to flush the shared data during the **sync** system call. If this directory is mounted on a regular disk partition, then disk traffic will be generated during the **sync** system call to keep the

shared data updated in the mapped disk file. Whether the data that are written to POSIX shared memory are saved in a file or not, those data do not persist following a reboot of the system. The POSIX shared memory functionality is described in the “POSIX Shared Memory” section of this chapter.

POSIX Message Queues

An application may consist of multiple cooperating processes, possibly running on separate processors. These processes may use system-wide POSIX message queues to efficiently communicate and coordinate their activities.

The primary use of POSIX message queues is for passing data between processes. In contrast, there is little need for functions that pass data between cooperating threads in the same process because threads within the same process already share the entire address space. However, nothing prevents an application from using message queues to pass data between threads in one or more processes.

Message queues are created and opened using `mq_open(3)`. This function returns a message queue descriptor (`mqd_t`), which is used to refer to the open message queue in later calls. Each message queue is identified by a name of the form `/somename`. Two processes can operate on the same queue by passing the same name to `mq_open`.

Messages are transferred to and from a queue using `mq_send(3)` and `mq_receive(3)`. When a process has finished using the queue, it closes it using `mq_close(3)`, and when the queue is no longer required, it can be deleted using `mq_unlink(3)`. Queue attributes can be retrieved and (in some cases) modified using `mq_getattr(3)` and `mq_setattr(3)`. A process can request asynchronous notification of the arrival of a message on a previously empty queue using `mq_notify(3)`.

A message queue descriptor is a reference to an open message queue description (see `open(2)`). After a `fork(2)`, a child inherits copies of its parent's message queue descriptors, and these descriptors refer to the same open message queue descriptions as the corresponding descriptors in the parent. Corresponding descriptors in the two processes share the flags (`mq_flags`) that are associated with the open message queue description.

Each message has an associated priority, and messages are always delivered to the receiving process highest priority first.

Message queues are created in a virtual file system. This file system can be mounted using the following commands:

```
$ mkdir /dev/mqueue
$ mount -t mqueue none /dev/mqueue
```

After the file system has been mounted, the message queues on the system can be viewed and manipulated using the commands usually used for files (e.g., `ls(1)` and `rm(1)`).

Support for POSIX message queues is configurable via the `POSIX_MQUEUE` kernel configuration parameter. This option is enabled by default. A sample program is provided in Appendix A.

All applications that call message queue library routines must link in the real-time library, either statically or dynamically. The following example shows the typical command-line format:

```
gcc [options...] file -lrt ...
```

System V Messages

The System V message type of interprocess communication (IPC) allows processes (executing programs) to communicate through the exchange of data stored in buffers. This data is transmitted between processes in discrete portions called messages. Processes using this type of IPC can send and receive messages.

Before a process can send or receive a message, it must have the operating system generate the necessary software mechanisms to handle these operations. A process does this using the `msgget(2)` system call. In doing this, the process becomes the owner/creator of a message queue and specifies the initial operation permissions for all processes, including itself. Subsequently, the owner/creator can relinquish ownership or change the operation permissions using the `msgctl(2)` system call. However, the creator remains the creator as long as the facility exists. Other processes with permission can use `msgctl` to perform various other control functions.

Processes which have permission and are attempting to send or receive a message can suspend execution if they are unsuccessful at performing their operation. That is, a process which is attempting to send a message can wait until it becomes possible to post the message to the specified message queue; the receiving process isn't involved (except indirectly; for example, if the consumer isn't consuming, the queue space will eventually be exhausted) and vice versa. A process which specifies that execution is to be suspended is performing a *blocking message operation*. A process which does not allow its execution to be suspended is performing a *nonblocking message operation*.

A process performing a blocking message operation can be suspended until one of three conditions occurs:

- the operation is successful
- the process receives a signal
- the message queue is removed from the system

System calls make these message capabilities available to processes. The calling process passes arguments to a system call, and the system call either successfully or unsuccessfully performs its function. If the system call is successful, it performs its function and returns applicable information. Otherwise, -1 is returned to the process, and `errno` is set accordingly.

Using Messages

Before a message can be sent or received, a uniquely identified message queue and data structure must be created. The unique identifier is called the message queue identifier (*msgid*); it is used to identify or refer to the associated message queue and data structure. This identifier is accessible by any process in the system, subject to normal access restrictions.

A message queue's corresponding kernel data structures are used to maintain information about each message being sent or received. This information, which is used internally by the system, includes the following for each message:

- message type
- message text size
- message text address

There is one associated data structure for the uniquely identified message queue, `msgid_ds`. This data structure contains the following information related to the message queue:

- operation permissions data (operation permission structure)
- current number of bytes on the queue
- number of messages on the queue
- maximum number of bytes on the queue
- process identification (PID) of last message sender
- PID of last message receiver
- last message send time
- last message receive time
- last change time

NOTE

All C header files discussed in this chapter are located in the `/usr/include` subdirectories.

The definition of the associated message queue data structure `msqid_ds` includes the members shown in Figure 3-1.

Figure 3-1 Definition of `msqid_ds` Structure

```

struct ipc_perm msg_perm; /* structure describing operation permission */
__time_t msg_stime; /* time of last msgsnd command */
__time_t msg_rtime; /* time of last msgrcv command */
__time_t msg_ctime; /* time of last change */
unsigned long int __msg_cbytes; /* current number of bytes on queue */
msgqnum_t msg_qnum; /* number of messages currently on queue */
msglen_t msg_qbytes; /* max number of bytes allowed on queue */
__pid_t msg_lspid; /* pid of last msgsnd() */
__pid_t msg_lrpid; /* pid of last msgrcv() */

```

The C programming language data structure definition for `msqid_ds` should be obtained by including the `<sys/msg.h>` header file, even though this structure is actually defined in `<bits/msq.h>`.

The definition of the interprocess communication permissions data structure, `ipc_perm`, includes the members shown in Figure 3-2:

Figure 3-2 Definition of `ipc_perm` Structure

```

__key_t __key; /* Key. */
__uid_t uid; /* Owner's user ID. */
__gid_t gid; /* Owner's group ID. */
__uid_t cuid; /* Creator's user ID. */
__gid_t cgid; /* Creator's group ID. */
unsigned short int mode; /* Read/write permission. */
unsigned short int __seq; /* Sequence number. */

```

The C programming language data structure definition of `ipc_perm` should be obtained by including the `<sys/ipc.h>` header file, even though the actual definition for this structure is located in `<bits/ipc.h>`. Note that `<sys/ipc.h>` is commonly used for all IPC facilities.

The `msgget(2)` system call performs one of two tasks:

- creates a new message queue identifier and creates an associated message queue and data structure for it
- locates an existing message queue identifier that already has an associated message queue and data structure

Both tasks require a *key* argument passed to the `msgget` system call. If *key* is not already in use for an existing message queue identifier, a new identifier is returned with an

associated message queue and data structure created for the key, provided no system tunable parameter would be exceeded.

There is also a provision for specifying a *key* of value zero (0), known as the private key (IPC_PRIVATE). When this key is specified, a new identifier is always returned with an associated message queue and data structure created for it, unless a system limit for the maximum number of message queues (MSGMNI) would be exceeded. The **ipcs(8)** command will show the *key* field for the *msgid* as all zeros.

If a message queue identifier exists for the key specified, the value of the existing identifier is returned. If you do not want to have an existing message queue identifier returned, a control command (IPC_EXCL) can be specified (set) in the *msgflg* argument passed to the system call (see “The msgget System Call” for details of this system call).

When a message queue is created, the process that calls **msgget** becomes the owner/creator, and the associated data structure is initialized accordingly. Remember, ownership can be changed but the creating process always remains the creator. The message queue creator also determines the initial operation permissions for it.

Once a uniquely identified message queue has been created or an existing one is found, **msgop(2)** (message operations) and **msgctl(2)** (message control) can be used.

Message operations, as mentioned before, consist of sending and receiving messages. The **msgsnd** and **msgrcv** system calls are provided for each of these operations (see “The msgsnd and msgrcv System Calls” for details of these calls).

The **msgctl** system call permits you to control the message facility in the following ways:

- by retrieving the data structure associated with a message queue identifier (IPC_STAT)
- by changing operation permissions for a message queue (IPC_SET)
- by changing the size (*msg_qbytes*) of the message queue for a particular message queue identifier (IPC_SET)
- by removing a particular message queue identifier from the operating system along with its associated message queue and data structure (IPC_RMID)

See the section “The msgctl System Call” for details of the **msgctl** system call.

Refer to Appendix A for a sample program using System V message queues. Additional sample programs can be found online that illustrate in depth use of each of the System V system calls. These are referenced within the section in this chapter that explains the system call.

The msgget System Call

msgget(2) creates a new message queue or identifies an existing one.

This section describes the **msgget** system call. For more detailed information, see the **msgget(2)** man page. A program illustrating use of this call can be found at `/usr/share/doc/ccur/examples/msgget.c` with extensive comments provided in `README.msgget.txt`.

Synopsis

```
#include <sys/types.h>
#include <sys/ipc.h>
#include <sys/msg.h>

int msgget (key_t key, int msgflg);
```

All of the `#include` files are located in the `/usr/include` subdirectories of the operating system.

`key_t` is defined by a typedef in the `<bits/types.h>` header file to be an integral type (this header file is included internally by `<sys/types.h>`). The integer returned from this function upon successful completion is the unique message queue identifier, *msqid*. (The *msqid* is discussed in the “Using Messages” section earlier in this chapter.) Upon failure, the external variable `errno` is set to indicate the reason for failure and `-1` is returned.

A new *msqid* with an associated message queue and data structure is created if one of the following conditions is true:

- *key* is equal to `IPC_PRIVATE`
- *key* does not already have a *msqid* associated with it and (*msgflg* and `IPC_CREAT`) is “true” (not zero).

The value of *msgflg* is a combination of:

- control commands (flags)
- operation permissions

Control commands are predefined constants. The following control commands apply to the **msgget** system call and are defined in the `<bits/ipc.h>` header file, which is internally included by the `<sys/ipc.h>` header file:

<code>IPC_CREAT</code>	used to create a new segment. If not used, msgget will find the message queue associated with <i>key</i> , verify access permissions and ensure the segment is not marked for destruction.
<code>IPC_EXCL</code>	used with <code>IPC_CREAT</code> to cause the system call to return an error if a message queue identifier already exists for the specified <i>key</i> . This is necessary to prevent the process from thinking it has received a new (unique) identifier when it has not.

Operation permissions determine the operations that processes are permitted to perform on the associated message queue. “Read” permission is necessary for receiving messages

or for determining queue status by means of a `msgctl` IPC_STAT operation. “Write” permission is necessary for sending messages.

Table 3-1 shows the numeric values (expressed in octal notation) for the valid operation permissions codes.

Table 3-1 Message Queue Operation Permissions Codes

Operation Permissions	Octal Value
Read by User	00400
Write by User	00200
Read by Group	00040
Write by Group	00020
Read by Others	00004
Write by Others	00002

A specific value is derived by adding or bitwise ORing the octal values for the operation permissions desired. That is, if “read by user” and “read/write by others” is desired, the code value would be 00406 (00400 plus 00006).

The `msgflg` value can easily be set by using the flag names in conjunction with the octal operation permissions value; for example:

```
msqid = msgget (key, (IPC_CREAT | 0400));
msqid = msgget (key, (IPC_CREAT | IPC_EXCL | 0400));
```

The system call will always be attempted. Exceeding the MSGMNI limit always causes a failure. The MSGMNI limit value determines the system-wide number of unique message queues that may be in use at any given time. This limit value is a fixed define value located in `<linux/msg.h>`.

A list of message queue limit values may be obtained with the `ipcs(8)` command by using the following options. See the man page for further details.

```
ipcs -q -l
```

Refer to the `msgget(2)` man page for specific associated data structure initialization as well as the specific error conditions.

The msgctl System Call

msgctl(2) is used to perform control operations on message queues.

This section describes the **msgctl(2)** system call. For more detailed information, see the **msgctl(2)** man page. A program illustrating use of this call can be found at `/usr/share/doc/ccur/examples/msgctl.c` with extensive comments provided in `README.msgctl.txt`.

Synopsis

```
#include <sys/types.h>
#include <sys/ipc.h>
#include <sys/msg.h>

int msgctl (int msqid, int cmd, struct msqid_ds *buf);
```

All of the `#include` files are located in the `/usr/include` subdirectories of the operating system.

The **msgctl** system call returns an integer value, which is zero for successful completion or -1 otherwise.

The *msqid* variable must be a valid, non-negative integer value that has already been created using the **msgget** system call.

The *cmd* argument can be any one of the following values:

IPC_STAT	returns the status information contained in the associated data structure for the specified message queue identifier, and places it in the data structure pointed to by the <i>buf</i> pointer in the user memory area. Read permission is required.
IPC_SET	writes the effective user and group identification, operation permissions, and the number of bytes for the message queue to the values contained in the data structure pointed to by the <i>buf</i> pointer in the user memory area
IPC_RMID	removes the specified message queue along with its associated data structure

NOTE

The **msgctl(2)** service also supports the `IPC_INFO`, `MSG_STAT` and `MSG_INFO` commands. However, since these commands are only intended for use by the **ipcs(8)** utility, these commands are not discussed.

To perform an IPC_SET or IPC_RMID control command, a process must meet one or more of the following conditions:

- have an effective user id of OWNER
- have an effective user id of CREATOR
- be the super-user
- have the CAP_SYS_ADMIN capability

Additionally, when performing an IPC_SET control command that increases the size of the `msg_qbytes` value beyond the value of `MSGMNB` (defined in `<linux/msg.h>`), the process must have the `CAP_SYS_RESOURCE` capability.

Note that a message queue can also be removed by using the `ipcrm(8)` command by specifying the `-q msgid` or the `-Q msgkey` option, where `msgid` specifies the identifier for the message queue and `msgkey` specifies the key associated with the message queue. To use this command, the user must have the same effective user id or capability that is required for performing an IPC_RMID control command. See the `ipcrm(8)` man page for additional information on the use of this command.

The msgsnd and msgrcv System Calls

The message operations system calls, `msgsnd` and `msgrcv`, are used to send and receive messages.

This section describes the `msgsnd` and `msgrcv` system calls. For more detailed information, see the `msgop(2)` man page. A program illustrating use of these calls can be found at `/usr/share/doc/ccur/examples/msgop.c` with extensive comments provided in `README.msgop.txt`.

Synopsis

```
#include <sys/types.h>
#include <sys/ipc.h>
#include <sys/msg.h>

int msgsnd (int msqid, void *msgp, size_t msgsz, int msgflg);

int msgrcv (int msqid, void *msgp, size_t msgsz, long msgtyp,
            int msgflg);
```

All of the `#include` files are located in the `/usr/include` subdirectories of the operating system.

Sending a Message

The `msgsnd` system call returns an integer value, which is zero for successful completion or -1 otherwise.

The `msqid` argument must be a valid, non-negative integer value that has already been created using the `msgget` system call.

The *msgp* argument is a pointer to a structure in the user memory area that contains the type of the message and the message to be sent.

The *msgsz* argument specifies the length of the character array in the data structure pointed to by the *msgp* argument. This is the length of the message. The maximum size of this array is determined by the MSGMAX define, which is located in `<linux/msg.h>`.

The *msgflg* argument allows the blocking message operation to be performed if the IPC_NOWAIT flag is not set ($(msgflg \& IPC_NOWAIT) = 0$); the operation blocks if the total number of bytes allowed on the specified message queue are in use (*msg_qbytes*). If the IPC_NOWAIT flag is set, the system call fails and returns -1.

Receiving a Message

When the **msgrcv** system call is successful, it returns the number of bytes received; when unsuccessful it returns -1.

The *msgid* argument must be a valid, non-negative, integer value. In other words, it must have already been created by using the **msgget** system call.

The *msgp* argument is a pointer to a structure in the user memory area that will receive the message type and the message text.

The *msgsz* argument specifies the length of the message to be received. If its value is less than the message in the array, an error can be returned if desired (see the *msgflg* argument below).

The *msgtyp* argument is used to pick the first message on the message queue of the particular type specified:

- If *msgtyp* is equal to zero, the first message on the queue is received.
- If *msgtyp* is greater than zero and the MSG_EXCEPT *msgflg* is **not set**, the first message of the same type is received.
- If *msgtyp* is greater than zero and the MSG_EXCEPT *msgflg* is **set**, the first message on the message queue that is **not equal to** *msgtyp* is received.
- If *msgtyp* is less than zero, the lowest message type that is less than or equal to the absolute value of *msgtyp* is received.

The *msgflg* argument allows the blocking message operation to be performed if the IPC_NOWAIT flag is not set ($(msgflg \& IPC_NOWAIT) == 0$); the operation blocks if the total number of bytes allowed on the specified message queue are in use (*msg_qbytes*). If the IPC_NOWAIT flag is set, the system call fails and returns a -1. And, as mentioned in the previous paragraph, when the MSG_EXCEPT flag is set in the *msgflg* argument and the *msgtyp* argument is greater than 0, the first message in the queue that has a message type that is different from the *msgtyp* argument is received.

If the IPC_NOWAIT flag is set, the system call fails immediately when there is not a message of the desired type on the queue. *msgflg* can also specify that the system call fail if the message is longer than the size to be received; this is done by not setting the MSG_NOERROR flag in the *msgflg* argument ($(msgflg \& MSG_NOERROR) == 0$). If the MSG_NOERROR flag is set, the message is truncated to the length specified by the *msgsz* argument of **msgrcv**.

POSIX Shared Memory

The POSIX shared memory interfaces allow cooperating processes to share data and more efficiently communicate through the use of a shared memory object. A *shared memory object* is defined as a named region of storage that is independent of the file system and can be mapped to the address space of one or more processes to allow them to share the associated memory.

The interfaces are briefly described as follows:

shm_open	create a shared memory object and establish a connection between the shared memory object and a file descriptor
shm_unlink	remove the name of a shared memory object

Procedures for using the **shm_open** routine are presented in “Using the shm_open Routine.” Procedures for using the **shm_unlink** routine are presented in “Using the shm_unlink Routine.”

In order for cooperating processes to use these interfaces to share data, one process completes the following steps. Note that the order in which the steps are presented is typical, but it is not the only order that you can use.

- STEP 1: Create a shared memory object and establish a connection between that object and a file descriptor by invoking the **shm_open** library routine, specifying a unique name, and setting the **O_CREAT** and the **O_RDWR** bit to open the shared memory object for reading and writing.
- STEP 2: Set the size of the shared memory object by invoking the **ftruncate(2)** system call and specifying the file descriptor obtained in Step 1. This system call requires that the memory object be open for writing. For additional information on **ftruncate(2)**, refer to the corresponding man page.
- STEP 3: Map a portion of the process's virtual address space to the shared memory object by invoking the **mmap(2)** system call and specifying the file descriptor obtained in Step 1 (see the “Memory Mapping” chapter for an explanation of this system call).

To use the shared memory object, any other cooperating process completes the following steps. Note that the order in which the steps are presented is typical, but it is not the only order that you can use.

- STEP 1: Establish a connection between the shared memory object created by the first process and a file descriptor by invoking the **shm_open** library routine and specifying the same name that was used to create the object.
- STEP 2: If the size of the shared memory object is not known, obtain the size of the shared memory object by invoking the **fstat(2)** system call and specifying the file descriptor

obtained in Step 1 and a pointer to a `stat` structure (this structure is defined in `<sys/stat.h>`). The size of the object is returned in the `st_size` field of the `stat` structure. Access permissions associated with the object are returned in the `st_modes` field. For additional information on `fstat(2)`, refer to the corresponding system manual page.

STEP 3: Map a portion of the process's virtual address space to the shared memory object by invoking `mmap` and specifying the file descriptor obtained in Step 1 (see the "Memory Mapping" chapter for an explanation of this system call).

Using the `shm_open` Routine

The `shm_open(3)` routine allows the calling process to create a POSIX shared memory object and establish a connection between that object and a file descriptor. A process subsequently uses the file descriptor that is returned by `shm_open` to refer to the shared memory object on calls to `ftruncate(2)`, `fstat(2)`, and `mmap(2)`. After a process creates a shared memory object, other processes can establish a connection between the shared memory object and a file descriptor by invoking `shm_open` and specifying the same name.

After a shared memory object is created, all data in the shared memory object remain until every process removes the mapping between its address space and the shared memory object by invoking `munmap(2)`, `exec(2)`, or `exit(2)` and one process removes the name of the shared memory object by invoking `shm_unlink(3)`. Neither the shared memory object nor its name is valid after your system is rebooted.

Synopsis

```
#include <sys/types.h>
#include <sys/mman.h>

int shm_open(const char *name, int oflag, mode_t mode);
```

The arguments are defined as follows:

name a pointer to a null-terminated string that specifies the name of the shared memory object. Note that this string may contain a maximum of 255 characters. It may contain a leading slash (/) character, but it may not contain embedded slash characters. Note that this name is not a part of the file system; neither a leading slash character nor the current working directory affects interpretation of it (`/shared_obj` and `shared_obj` are interpreted as the same name). If you wish to write code that can be ported to any system that supports POSIX interfaces, however, it is recommended that *name* begin with a slash character.

oflag an integer value that sets one or more of the following bits:

Note that `O_RDONLY` and `O_RDWR` are mutually exclusive bits; one of them must be set.

O_RDONLY	causes the shared memory object to be opened for reading only
O_RDWR	causes the shared memory object to be opened for reading and writing. Note that the process that creates the shared memory object must open it for writing in order to be able to set its size by invoking ftruncate(2) .
O_CREAT	causes the shared memory object specified by <i>name</i> to be created if it does not exist. The memory object's user ID is set to the effective user ID of the calling process; its group ID is set to the effective group ID of the calling process; and its permission bits are set as specified by the <i>mode</i> argument. If the shared memory object specified by <i>name</i> exists, setting O_CREAT has no effect except as noted for O_EXCL.
O_EXCL	causes shm_open to fail if O_CREAT is set and the shared memory object specified by <i>name</i> exists. If O_CREAT is not set, this bit is ignored.
O_TRUNC	causes the length of the shared memory object specified by <i>name</i> to be truncated to zero if the object exists and has been opened for reading and writing. The owner and the mode of the specified shared memory object are unchanged.

mode an integer value that sets the permission bits of the shared memory object specified by *name* with the following exception: bits set in the process's file mode creation mask are cleared in the shared memory object's mode (refer to the **umask(2)** and **chmod(2)** man pages for additional information). If bits other than the permission bits are set in *mode*, they are ignored. A process specifies the *mode* argument only when it is creating a shared memory object.

If the call is successful, **shm_open** creates a shared memory object of size zero and returns a file descriptor that is the lowest file descriptor not open for the calling process. The FD_CLOEXEC file descriptor flag is set for the new file descriptor; this flag indicates that the file descriptor identifying the shared memory object will be closed upon execution of the **exec(2)** system call (refer to the **fcntl(2)** system manual page for additional information).

A return value of `-1` indicates that an error has occurred; `errno` is set to indicate the error. Refer to the **shm_open(3)** man page for a listing of the types of errors that may occur.

Using the `shm_unlink` Routine

The `shm_unlink(3)` routine allows the calling process to remove the name of a shared memory object. If one or more processes have a portion of their address space mapped to the shared memory object at the time of the call, the name is removed before `shm_unlink` returns, but data in the shared memory object are not removed until the last process removes its mapping to the object. The mapping is removed if a process invokes `munmap(2)`, `exec(2)`, or `exit(2)`.

Synopsis

```
#include <sys/types.h>
#include <sys/mman.h>

int shm_unlink(const char *name);
```

The argument is defined as follows:

<i>name</i>	a pointer to a null-terminated string that specifies the shared memory object name that is to be removed. Note that this string may contain a maximum of 255 characters. It may contain a leading slash (/) character, but it may <u>not</u> contain embedded slash characters. Note that this name is not a part of the file system; neither a leading slash character nor the current working directory affects interpretation of it (<code>/shared_obj</code> and <code>shared_obj</code> are interpreted as the same name). If you wish to write code that can be ported to any system that supports POSIX interfaces, however, it is recommended that <i>name</i> begin with a slash character.
-------------	---

A return value of 0 indicates that the call to `shm_unlink` has been successful. A return value of -1 indicates that an error has occurred; `errno` is set to indicate the error. Refer to the `shm_unlink(3)` man page for a listing of the types of errors that may occur. If an error occurs, the call to `shm_unlink` does not change the named shared memory object.

System V Shared Memory

Shared memory allows two or more processes to share memory and, consequently, the data contained therein. This is done by allowing processes to set up access to a common virtual memory address space. This sharing occurs on a segment basis, which is memory management hardware-dependent.

A process initially creates a shared memory segment using the `shmget(2)` system call. Upon creation, this process sets the overall operation permissions for the shared memory segment, sets its size in bytes, and can specify that the shared memory segment is for reference only (read-only) upon attachment.

If the memory segment is not specified to be for reference only, all other processes with appropriate operation permissions can read from or write to the memory segment.

The shared memory segments on the system are visible via the `/proc/sysvipc/shm` file and `ipcs(8)` using the `-m` option.

Shared memory operations, **shmat(2)** (shared memory attach) and **shmdt(2)** (shared memory detach), can be performed on a shared memory segment. **shmat** allows processes to associate themselves with the shared memory segment if they have permission. They can then read or write as allowed. **shmdt** allows processes to disassociate themselves from a shared memory segment. Therefore, they lose the ability to read from or write to the shared memory segment.

The original owner/creator of a shared memory segment can relinquish ownership to another process using the **shmctl(2)** system call. However, the creating process remains the creator until the facility is removed or the system is reinitialized. Other processes with permission can perform other functions on the shared memory segment using the **shmctl** system call.

A process can bind a shared memory segment to a section of I/O memory by using the **shmbind(2)** system call. See the section “Binding a Shared Memory Segment to I/O Space” for details of the **shmbind** system call.

To facilitate use of shared memory by cooperating programs, a utility called **shmdefine(1)** is provided. Procedures for using this utility are explained in “The shmdefine Utility”. To assist you in creating a shared memory segment and binding it to a section of physical memory, a utility called **shmconfig(1)** is also provided. Procedures for using this utility are explained in “The shmconfig Command”.

Using Shared Memory

Sharing memory between processes occurs on a virtual segment basis. There is only one copy of each individual shared memory segment existing in the operating system at any time.

Before sharing of memory can be realized, a uniquely identified shared memory segment and data structure must be created. The unique identifier created is called the shared memory identifier (*shmid*); it is used to identify or refer to the associated data structure. This identifier is available to any process in the system, subject to normal access restrictions.

The data structure includes the following for each shared memory segment:

- Operation permissions
- Segment size
- Segment descriptor (for internal system use only)
- PID performing last operation
- PID of creator
- Current number of processes attached
- Last attach time
- Last detach time
- Last change time

The definition of the associated shared memory segment data structure `shmid_ds` includes the members shown in Figure 3-3.

Figure 3-3 Definition of `shmid_ds` Structure

```

struct shmid_ds {
    struct ipc_perm shm_perm; /* operation perms */
    int shm_segsz; /* size of segment (bytes) */
    time_t shm_atime; /* last attach time */
    time_t shm_dtime; /* last detach time */
    time_t shm_ctime; /* last change time */
    unsigned short shm_cpid; /* pid of creator */
    unsigned short shm_lpid; /* pid of last operator */
    short shm_nattch; /* no. of current attaches */
};

```

The C programming language data structure definition for the shared memory segment data structure `shmid_ds` is located in the `<sys/shm.h>` header file.

Note that the `shm_perm` member of this structure uses `ipc_perm` as a template. The `ipc_perm` data structure is the same for all IPC facilities; it is located in the `<sys/ipc.h>` header file.

The `shmget(2)` system call performs two tasks:

- It gets a new shared memory identifier and creates an associated shared memory segment data structure.
- It returns an existing shared memory identifier that already has an associated shared memory segment data structure.

The task performed is determined by the value of the *key* argument passed to the `shmget` system call.

The *key* can be an integer that you select, or it can be an integer that you have generated by using the `ftok` subroutine. The `ftok` subroutine generates a key that is based upon a path name and identifier that you supply. By using `ftok`, you can obtain a unique key and control users' access to the key by limiting access to the file associated with the path name. If you wish to ensure that a key can be used only by cooperating processes, it is recommended that you use `ftok`. This subroutine is specified as follows:

```
key_t ftok( path_name, id )
```

The *path_name* argument specifies a pointer to the path name of an existing file that should be accessible to the calling process. The *id* argument specifies a character that uniquely identifies a group of cooperating processes. `ftok` returns a key that is based on the specified *path_name* and *id*. Additional information on the use of `ftok` is provided in the `ftok(3)` man page.

If the *key* is not already in use for an existing shared memory identifier and the `IPC_CREAT` flag is set in *shmflg*, a new identifier is returned with an associated shared memory segment data structure created for it provided no system-tunable parameters would be exceeded.

There is also a provision for specifying a *key* of value zero which is known as the private key (IPC_PRIVATE); when specified, a new *shmid* is always returned with an associated shared memory segment data structure created for it unless a system-tunable parameter would be exceeded. The **ipcs(8)** command will show the *key* field for the *shmid* as all zeros.

If a *shmid* exists for the *key* specified, the value of the existing *shmid* is returned. If it is not desired to have an existing *shmid* returned, a control command (IPC_EXCL) can be specified (set) in the *shmflg* argument passed to the system call.

When a new shared memory segment is created, the process that calls **shmget** becomes the owner/creator, and the associated data structure is initialized accordingly. Remember, ownership can be changed, but the creating process always remains the creator (see “The shmctl System Call”). The creator of the shared memory segment also determines the initial operation permissions for it.

Once a uniquely identified shared memory segment data structure is created, **shmbind**, **shmctl**, and shared memory operations (**shmop**) can be used.

The **shmbind** system call allows you to bind a shared memory segment to a section of I/O memory. See the section “Binding a Shared Memory Segment to I/O Space” for details of the **shmbind** system call.

The **shmctl(2)** system call permits you to control the shared memory facility in the following ways:

- by retrieving the data structure associated with a shared memory segment (IPC_STAT)
- by changing operation permissions for a shared memory segment (IPC_SET)
- by removing a particular shared memory segment from the operating system along with its associated shared memory segment data structure (IPC_RMID)
- by locking a shared memory segment in memory (SHM_LOCK)
- by unlocking a shared memory segment (SHM_UNLOCK)

See the section “The shmctl System Call” for details of the **shmctl** system call.

Shared memory segment operations (**shmop**) consist of attaching and detaching shared memory segments. **shmat** and **shmdt** are provided for each of these operations (see “The shmat and shmdt System Calls” for details of the **shmat** and **shmdt** system calls).

It is important to note that the **shmdefine(1)** and **shmconfig(1)** utilities also allow you to create shared memory segments. See the section “Shared Memory Utilities” for information about these utilities.

The shmget System Call

shmget(2) creates a new shared memory segment or identifies an existing one.

This section describes the **shmget** system call. For more detailed information, see the **shmget(2)** man page. A program illustrating use of this call can be found at `/usr/share/doc/ccur/examples/shmget.c` with extensive comments provided in `README.shmget.txt`.

Synopsis

```
#include <sys/ipc.h>
#include <sys/shm.h>

int shmget (key_t key, size_t size, int shmflg);
```

All of these `#include` files are located in the `/usr/include` subdirectories of the operating system.

`key_t` is defined by a typedef in the `<bits/sys/types.h>` header file to be an integral type (this header file is included internally by `<sys/types.h>`). The integer returned from this system call upon successful completion is the shared memory segment identifier (*shmid*) associated to the value of *key*. (The *shmid* is discussed in the section “Using Shared Memory” earlier in this chapter.) Upon failure, the external variable `errno` is set to indicate the reason for failure, and -1 is returned.

A new *shmid* with an associated shared memory data structure is created if one of the following conditions is true:

- *key* is equal to `IPC_PRIVATE`.
- *key* does not already have a *shmid* associated with it and (*shmflg* and `IPC_CREAT`) is “true” (not zero).

The value of *shmflg* is a combination of:

- control commands (flags)
- operation permissions

Control commands are predefined constants. The following control commands apply to the **shmget** system call and are defined in the `<bits/ipc.h>` header file, which is internally included by the `<sys/ipc.h>` header file:

<code>IPC_CREAT</code>	used to create a new segment. If not used, shmget will find the segment associated with <i>key</i> , verify access permissions and ensure the segment is not marked for destruction.
<code>IPC_EXCL</code>	used with <code>IPC_CREAT</code> to cause the system call to return an error if a shared memory identifier already exists for the specified <i>key</i> . This is necessary to prevent the process from thinking it has received a new (unique) identifier when it has not.

Operation permissions define the read/write attributes for users, groups, and others. Table 3-2 shows the numeric values (expressed in octal notation) for the valid operation permissions codes.

Table 3-2 Shared Memory Operation Permissions Codes

Operation Permissions	Octal Value
Read by User	00400
Write by User	00200
Read by Group	00040
Write by Group	00020
Read by Others	00004
Write by Others	00002

A specific value is derived by adding or bitwise ORing the octal values for the operation permissions desired. That is, if “read by user” and “read/write by others” is desired, the code value would be 00406 (00400 plus 00006). The SHM_R and SHM_W constants located in **<sys/shm.h>** can be used to define read and write permission for the owner.

The *shmflg* value can easily be set by using the flag names in conjunction with the octal operation permissions value; for example:

```
shmids = shmget (key, size, (IPC_CREAT | 0400));
shmids = shmget (key, size, (IPC_CREAT | IPC_EXCL | 0400));
```

The following values are defined in **<sys/shm.h>**. Exceeding these values always causes a failure.

SHMMNI	determines the maximum number of unique shared memory segments (<i>shmids</i>) that can be in use at any given time
SHMMIN	determines the minimum shared memory segment size
SHMMAX	determines the maximum shared memory segment size
SHMALL	determines the maximum shared memory pages

A list of shared memory limit values can be obtained with the **ipcs(8)** command by using the following options. See the man page for further details.

```
ipcs -m -l
```

Refer to the **shmget(2)** man page for specific associated data structure initialization as well as specific error conditions.

The shmctl System Call

shmctl(2) is used to perform control operations on shared memory segments.

This section describes the **shmctl** system call. For more detailed information, see the **shmctl(2)** man page. A program illustrating use of this call can be found at `/usr/share/doc/ccur/examples/shmctl.c` with extensive comments provided in `README.shmctl.txt`.

Synopsis

```
#include <sys/ipc.h>
#include <sys/shm.h>

int shmctl (int shmid, int cmd, struct shmctl_ds *buf);
```

All of these `#include` files are located in the `/usr/include` subdirectories of the operating system.

The **shmctl** system call returns an integer value, which is zero for successful completion or -1 otherwise.

The *shmid* variable must be a valid, non-negative integer value that has already been created using the **shmget** system call.

The *cmd* argument can be any one of following values:

IPC_STAT	returns the status information contained in the associated data structure for the specified <i>shmid</i> and places it in the data structure pointed to by the <i>buf</i> pointer in the user memory area. Read permission is required.
IPC_SET	sets the effective user and group identification and operation permissions for the specified <i>shmid</i>
IPC_RMID	removes the specified <i>shmid</i> along with its associated data structure
SHM_LOCK	prevents swapping of a shared memory segment. The user must fault in any pages that are required to be present after locking is enabled. The process must have superuser or CAP_IPC_LOCK privileges to perform this operation.
SHM_UNLOCK	unlocks the shared memory segment from memory. The process must have superuser or CAP_IPC_LOCK privileges to perform this operation.

NOTE

The **shmctl(2)** service also supports the IPC_INFO, SHM_STAT and SHM_INFO commands. However, since these commands are only intended for use by the **ipcs(8)** utility, these commands are not discussed.

To perform an IPC_SET or IPC_RMID control command, a process must meet one or more of the following conditions:

- have an effective user id of OWNER
- have an effective user id of CREATOR
- be the super-user
- have the CAP_SYS_ADMIN capability

Note that a shared memory segment can also be removed by using the **ipcrm(1)** command and specifying the **-m shm_{id}** or the **-M shm_{key}** option, where *shm_{id}* specifies the identifier for the shared memory segment and *shm_{key}* specifies the key associated with the segment. To use this command, a process must have the same privileges as those required for performing an IPC_RMID control command. See the **ipcrm(1)** man page for additional information on the use of this command.

Binding a Shared Memory Segment to I/O Space

RedHawk Linux allows you to bind a shared memory segment to a region of I/O space. The procedures for doing so are as follows.

1. Create a shared memory segment (**shmget(2)**).
2. Obtain the physical address of the I/O region using the PCI BAR scan routines.
3. Bind the segment to I/O memory (**shmbind(2)**).
4. Attach the segment to the user's virtual address space (**shmat(2)**).

At command level, the **shmconfig(1)** utility can be used to create a shared memory segment and bind it to a physical memory region. Refer to the section "Shared Memory Utilities" for details.

You can attach a shared memory segment to and detach it from the user's virtual address space by using the **shmat** and **shmdt** system calls. Procedures for using these system calls are explained in "The shmat and shmdt System Calls."

Using shmget

The **shmget(2)** system call is invoked first to create a shared memory segment. Upon successful completion of the call, a shared memory segment of *size* bytes is created, and an identifier for the segment is returned.

When binding to I/O space, the size of the region can be obtained using the PCI BAR scan routines (see **bar_scan_open(3)**).

Complete information on the use of **shmget** is provided in "The shmget System Call."

Using shmbind

After you have created a shared memory segment, you can bind it to a region of I/O space by using the **shmbind(2)** system call. Note that to use this call, you must be root or have the `CAP_SYS_RAWIO` privilege.

shmbind must be called before the first process attaches to the segment. Thereafter, attaching to the segment via **shmat()** effectively creates a mapping in the calling process' virtual address space to the region of the physical address space.

The region of I/O space is defined by its starting address and the size of the shared memory segment to which it is being bound. The starting address must be aligned with a page boundary. The size of the shared memory segment has been established by specifying the *size* argument on the call to **shmget**. If you have created a shared memory segment of 1024 bytes, for example, and you wish to bind it to a section of physical memory that starts at location 0x2000000 (hexadecimal representation), the bound section of physical memory will include memory locations 0x2000000 through 0x2000BFF.

Be aware that the physical address for a device may change due to hardware changes in the system. To reliably reference a device, the physical address should be obtained using the PCI BAR scan routines; refer to the **bar_scan_open(3)** man page.

The specifications required for making the call to **shmbind** are as follows:

```
int shmbind(int shmid, unsigned long paddr)
```

Arguments are defined as follows:

<i>shmid</i>	the identifier for the shared memory segment that you wish to bind to a section of physical memory
<i>paddr</i>	the starting physical address of the section of memory to which you wish to bind the specified shared memory segment

The shmat and shmdt System Calls

The shared memory operations system calls, **shmat** and **shmdt**, are used to attach and detach shared memory segments to/from the address space of the calling process.

This section describes the **shmat** and **shmdt** system calls. For more detailed information, see the **shmop(2)** man page. A program illustrating use of these calls can be found at `/usr/share/doc/ccur/examples/shmop.c` with extensive comments provided in `README.shmop.txt`.

Synopsis

```
#include <sys/types.h>
#include <sys/shm.h>

void *shmat (int shmid, const void *shmaddr, int shmflg);
int shmdt (const void *shmaddr);
```

All of these `#include` files are located in the `/usr/include` subdirectories of the operating system.

Attaching a Shared Memory Segment

The **shmat** system call attaches the shared memory segment identified by *shmid* to the address space of the calling process. It returns a character pointer value. Upon successful completion, this value will be the address in memory where the process is attached to the shared memory segment; when unsuccessful, the value will be -1.

The *shmid* argument must be a valid, non-negative, integer value. It must have been created previously using the **shmget** system call.

The *shmaddr* argument can be zero or user supplied when passed to the **shmat** system call. If it is zero, the operating system selects the address where the shared memory segment will be attached. If it is user-supplied, the address must be a valid page-aligned address within the program's address space. The following illustrates some typical address ranges:

```
0xc00c0000
0xc00e0000
0xc0100000
0xc0120000
```

Allowing the operating system to select addresses improves portability.

The *shmflg* argument is used to pass the SHM_RND (round down) and SHM_RDONLY (read only) flags to the **shmat** system call.

Detaching Shared Memory Segments

The **shmdt** system call detaches the shared memory segment located at the address specified by *shmaddr* from the address space of the calling process. It returns an integer value, which is zero for successful completion or -1 otherwise.

Shared Memory Utilities

Redhawk Linux provides two utilities that facilitate use of shared memory segments. The **shmdefine(1)** utility allows you to create one or more shared memory segments that are to be used by cooperating programs. The **shmconfig(1)** command allows you to create a shared memory segment and bind it to a section of physical memory. These utilities are discussed in the sections that follow.

The shmdefine Utility

The **shmdefine** utility is designed to facilitate the use of shared memory by a set of cooperating programs. Although you may have a number of programs that will cooperate in using one or more shared memory segments, it is necessary to invoke the utility only once. Because **shmdefine** produces object files that must be linked to the source object file, you must invoke it prior to linking.

shmdefine currently operates with the GNU C, Fortran and Ada compilers (`gcc`, `g77`, `GNAT`) for programs that execute on RedHawk Linux systems.

Refer to the *Quick Reference for shmdefine* (publication number 0898010) and the **shmdefine(1)** man page for details on using this utility.

The shmconfig Command

The **shmconfig(1)** command assists in creating a shared memory segment associated with a certain key and optionally binding it to a particular section of I/O memory.

The command syntax is:

```
/usr/bin/shmconfig -i DEVSTR
/usr/bin/shmconfig -b BARSTR [-s SIZE] [-g GROUP] [-m MODE] [-u USER]
    {key} [-t FNAME]
/usr/bin/shmconfig -s SIZE [-p ADDR] [-g GROUP] [-m MODE] [-u USER]
    {key} [-t FNAME]
```

For information about assigning NUMA memory policies to shared memory areas, refer to Chapter 10 or the **shmconfig(1)** man page.

Options are described in Table 3-3.

Table 3-3 Options to the shmconfig(1) Command

Option	Description
--info=DEVSTR, -i DEVSTR	Prints information about each memory region on each device matching <i>DEVSTR</i> , which consists of: <i>vendor_id:device_id</i> Helpful when using --bind . See --bind for information on <i>DEVSTR</i> .
--bind=BARSTR, -b BARSTR	Identifies an I/O region in memory to be bound to the shared segment. <i>BARSTR</i> consists of: <i>vendor_id:device_id:bar_no[:dev_no]</i> <i>vendor_id</i> and <i>device_id</i> identify the hardware device; usually expressed as two hex values separated by a colon (e.g., 8086:100f). Can be obtained from the vendor's manual, <code>/usr/share/hwdata/pci.ids</code> or <code>lspci -ns</code> . Requires a "0x" base prefix when specifying these IDs; e.g., 0x8086:0x100f. See "Examples" below. <i>bar_no</i> identifies the memory region to be bound. Use -i option to obtain this value (output displays "Region <i>bar_no</i> : Memory at ..."). Only the memory regions can be bound. <i>dev_no</i> is optional and needed only to differentiate between multiple boards with matching vendor and device IDs. Use -i option to obtain this value (output displays "Logical device: <i>dev_no</i> :"). The user must have the CAP_SYS_RAWIO privilege to use this option.
--size=SIZE, -s SIZE	Specifies the size of the segment in bytes. Not required for --bind , where the default is the complete memory region.
--physical=ADDR, -p ADDR	Specifies <i>ADDR</i> as the starting address of the section of physical I/O memory to which the segment is to be bound. This option is being deprecated; use --bind . The user must have the CAP_SYS_RAWIO privilege to use this option.
--user=USER, -u USER	Specifies the login name of the owner of the shared memory segment.
--group=GROUP, -g GROUP	Specifies the name of the group to which group access to the segment is applicable.
--mode=MODE, -m MODE	Specifies <i>mode</i> as the set of permissions governing access to the shared memory segment. You must use the octal method to specify the permissions.
--help, -h	Describes available options and usage.
--version, -v	Prints out current version of the command.

The `/proc` and `/sys` file systems must be mounted in order to use this command.

It is important to note that the size of a segment as specified by the `-s` argument must match the size of the data that will be placed there. If `shmdefine` is being used, the size of the segment must match the size of the variables that are declared to be a part of the shared segment. Specifying a larger size will work. (For information on `shmdefine`, see “The `shmdefine` Utility.”)

It is recommended that you specify the `-u`, `-g`, and `-m` options to identify the user and group associated with the segment and to set the permissions controlling access to it. If not specified, the default user ID and group ID of the segment are those of the owner; the default mode is 0644.

The `key` argument represents a user-chosen identifier for a shared memory segment. This identifier can be either an integer or a standard path name that refers to an existing file. When a pathname is supplied, an `ftok(key, 0)` will be used as the key parameter for the `shmget(2)` call.

`--tmpfs=FNAME / -t FNAME` can be used to specify a tmpfs filesystem filename instead of a key. The `-u`, `-g` and `-m` options can be used to set or change the file attributes of this segment.

When `shmconfig` is executed, an internal data structure and shared memory segment are created for the specified key; if the `-p` option is used, the shared memory segment is bound to a contiguous section of I/O memory.

To access the shared memory segment that has been created by `shmconfig`, processes must first call `shmget(2)` to obtain the identifier for the segment. This identifier is required by other system calls for manipulating shared memory segments. The specification for `shmget` is:

```
int shmget(key, size, 0)
```

The value of `key` is determined by the value of `key` specified with `shmconfig`. If the value of `key` was an integer, that integer must be specified as `key` on the call to `shmget`. If the value of `key` was a path name, you must first call the `ftok` subroutine to obtain an integer value based on the path name to specify as `key` on the call to `shmget`. It is important to note that the value of the `id` argument on the call to `ftok` must be zero because `shmconfig` calls `ftok` with an `id` of zero when it converts the path name to a key. The value of `size` must be equal to the number of bytes specified by the `-s` argument to `shmconfig`. A value of 0 is specified as the `flag` argument because the shared memory segment has already been created.

For complete information about `shmget`, see “The `shmget` System Call.” For assistance in using `ftok`, see “Using Shared Memory” and the `ftok(3)` man page. When creating areas of mapped memory to be treated as global system resources, you may find it helpful to invoke `shmconfig` by adding a line to the `shmconfig` script in the `/etc/init.d` directory. Doing so allows you to reserve the IPC key before noncooperating processes have an opportunity to use it, and it enables you to establish the binding between the shared memory segment and physical memory before cooperating processes need to use the segment. Add a line similar to the following example:

```
/usr/bin/shmconfig -p 0xf00000 -s 0x10000 -u root -g sys -m 0666 key
```

Examples

In this example, a physical memory region on the RCIM is identified using `lspci(8)` and bound to a shared memory region. Note that you must be root to use `lspci`. If you don't have root privileges you can view `/usr/share/hwdata/pci.ids` and search for the device name (RCIM); id values are listed to the left of the vendor/device description. When two or more device ids are listed for the same device, use `shmconfig -i` on each `device_id` listed to determine which one to use.

1. Find the `bus:slot.func` identifier for the RCIM board:

```
# lspci -v | grep -i rcim
0d:06.0 System peripheral: Concurrent Computer Corp RCIM II
Realtime Clock ...
```

2. Use the rcim identifier to get the `vendor_id:device_id` numbers:

```
# lspci -ns 0d:06.0
0d:06.0 Class 0880: 1542:9260 (rev 01)
```

3. Find the memory regions for this device. Note that `lspci` prints the `vendor_id:device_id` values in hex format but without a 0x prefix (1542:9260), however `shmconfig` requires a base identifier (0x1542:0x9260).

```
# shmconfig -i 0x1542:0x9260
Region 0: Memory at f8d04000 (non-prefetchable) [size=256]
          /proc/bus/pci0/bus13/dev6/fn0/bar0
Region 1: I/O ports at 7c00 [size=256]
          /proc/bus/pci0/bus13/dev6/fn0/bar1
Region 2: Memory at f8d00000 (non-prefetchable) [size=16384]
          /proc/bus/pci0/bus13/dev6/fn0/bar2
```

4. Bind to rcim memory region #2:

```
# shmconfig -b 0x1542:0x9260:2 -m 0644 -u me -g mygroup 42
```

5. Verify the IPC shared memory regions on the system. Note that `physaddr` represents the physical address we have bound and matches the address reported by the `shmconfig -i` command in step 3 above.

```
# cat /proc/sysvipc/shm
      key      shmid perms      size cpid lpid natch  uid
gid  cuid  cgid   atime      dtime      ctime physaddr
 42   0     0     644     16384  1734    0      0  5388
100  0     0           0           0 1087227538 f8d00000
```

Process Scheduling

This chapter provides an overview of process scheduling on RedHawk Linux systems. It explains how the process scheduler decides which process to execute next and describes POSIX scheduling policies and priorities. It explains the procedures for using the program interfaces and commands that support process scheduling and discusses performance issues.

Overview

In the RedHawk Linux OS, the schedulable entity is always a process. Scheduling priorities and scheduling policies are attributes of processes. The system scheduler determines when processes run. It maintains priorities based on configuration parameters, process behavior and user requests; it uses these priorities as well as the CPU affinity to assign processes to a CPU.

The scheduler offers three different scheduling policies, one for normal non-critical processes (`SCHED_OTHER`), and two fixed-priority policies for real-time applications (`SCHED_FIFO` and `SCHED_RR`). These policies are explained in detail in the section “Scheduling Policies” on page 4-3.

By default, the scheduler uses the `SCHED_OTHER` time-sharing scheduling policy. For processes in the `SCHED_OTHER` policy, the scheduler manipulates the priority of runnable processes dynamically in an attempt to provide good response time to interactive processes and good throughput to CPU-intensive processes. .

Fixed-priority scheduling allows users to set static priorities on a per-process basis. The scheduler never modifies the priority of a process that uses one of the fixed priority scheduling policies. The highest real-time fixed-priority process always gets the CPU as soon as it is runnable, even if other processes are runnable. An application can therefore specify the exact order in which processes run by setting process priority accordingly.

For system environments in which real-time performance is not required, the default scheduler configuration works well, and no fixed-priority processes are needed. However, for real-time applications or applications with strict timing constraints, fixed-priority processes are the only way to guarantee that the critical application's requirements are met. When certain programs require very deterministic response times, fixed priority scheduling policies should be used and tasks that require the most deterministic response should be assigned the most favorable priorities.

A set of system calls based on IEEE Standard 1003.1b provides direct access to a process' scheduling policy and priority. Included in the set are system calls that allow processes to obtain or set a process' scheduling policy and priority; obtain the minimum and maximum priorities associated with a particular scheduling policy; and obtain the time quantum associated with a process scheduled under the round robin (`SCHED_RR`) scheduling policy. You may alter the scheduling policy and priority for a process at the command level by

using the **run(1)** command. The system calls and the **run** command are detailed later in this chapter along with procedures and hints for effective use.

How the Process Scheduler Works

Figure 4-1 illustrates how the scheduler operates.

Figure 4-1 The Scheduler

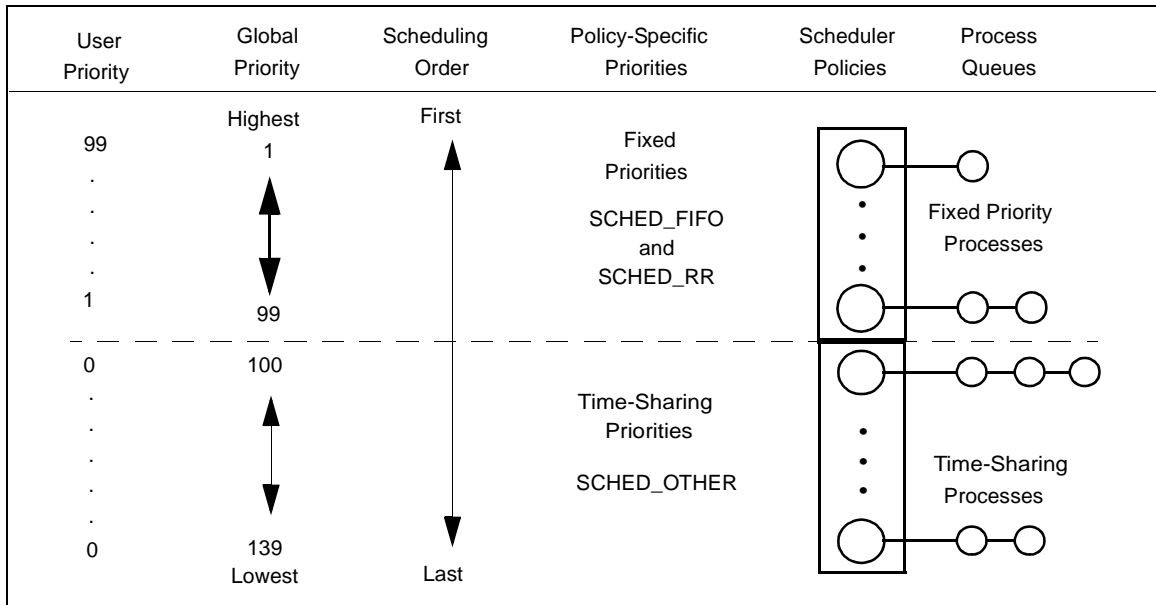

When a process is created, it inherits its scheduling parameters, including scheduling policy and a priority within that policy. Under the default configuration, a process begins as a time-sharing process scheduled with the SCHED_OTHER policy. In order for a process to be scheduled under a fixed-priority policy, a user-request must be made via system calls or the **run(1)** command.

When the user sets the priority of a process, he is setting the “user priority.” This is also the priority that will be reported by the **sched_getparam(2)** call when a user retrieves the current priority. A portable application should use the **sched_get_priority_min()** and **sched_get_priority_max()** interfaces to determine the range of valid priorities for a particular scheduling policy. A user priority value (*sched_priority*) is assigned to each process. SCHED_OTHER processes can only be assigned a user priority of 0. SCHED_FIFO and SCHED_RR processes have a user priority in the range 1 to 99.

The scheduler converts scheduling policy-specific priorities into global priorities. The global priority is the scheduling policy value used internally by the kernel. The scheduler maintains a list of runnable processes for each possible global priority value. There are 40 global scheduling priorities associated with the SCHED_OTHER scheduling policy; there are 99 global scheduling priorities associated with the fixed priority scheduling policies (SCHED_RR and SCHED_FIFO). The scheduler looks for the non-empty list with the highest global priority and selects the process at the head of this list for execution on the current

CPU. The scheduling policy determines for each process where it will be inserted into the list of processes with equal user priority and the process' relative position in this list when processes in the list are blocked or made runnable.

As long as a fixed-priority process is ready-to-run for a particular CPU, no time-sharing process will run on that CPU.

Once the scheduler assigns a process to the CPU, the process runs until it uses up its time quantum, sleeps, blocks or is preempted by a higher-priority process.

Note that the priorities displayed by `ps(1)` and `top(1)` are internally computed values and only indirectly reflect the priority set by the user.

Scheduling Policies

POSIX defines three types of scheduling policies that control the way a process is scheduled:

<code>SCHED_FIFO</code>	first-in-first-out (FIFO) scheduling policy
<code>SCHED_RR</code>	round-robin (RR) scheduling policy
<code>SCHED_OTHER</code>	default time-sharing scheduling policy

First-In-First-Out Scheduling (`SCHED_FIFO`)

`SCHED_FIFO` can only be used with user priorities higher than 0. That means when a `SCHED_FIFO` process becomes runnable, it will always immediately preempt any currently running `SCHED_OTHER` process. `SCHED_FIFO` is a simple scheduling algorithm without time slicing. For processes scheduled under the `SCHED_FIFO` policy, the following rules are applied: A `SCHED_FIFO` process that has been preempted by another process of higher priority will stay at the head of the list for its priority and will resume execution as soon as all processes of higher priority are blocked again. When a `SCHED_FIFO` process becomes runnable, it will be inserted at the end of the list for its priority. A call to `sched_setscheduler(2)` or `sched_setparam(2)` will put the `SCHED_FIFO` process identified by `pid` at the end of the list if it was runnable. A process calling `sched_yield(2)` will be put at the end of its priority list. No other events will move a process scheduled under the `SCHED_FIFO` policy in the wait list of runnable processes with equal user priority. A `SCHED_FIFO` process runs until either it is blocked by an I/O request, it is preempted by a higher priority process, or it calls `sched_yield`.

Round-Robin Scheduling (SCHED_RR)

SCHED_RR is a simple enhancement of SCHED_FIFO. Everything described above for SCHED_FIFO also applies to SCHED_RR, except that each process is only allowed to run for a maximum time quantum. If a SCHED_RR process has been running for a time period equal to or longer than the time quantum, it will be put at the end of the list for its priority. A SCHED_RR process that has been preempted by a higher priority process and subsequently resumes execution as a running process will complete the unexpired portion of its round robin time quantum. The length of the time quantum can be retrieved by `sched_rr_get_interval(2)`. The length of the time quantum is affected by the nice value associated with a process scheduled under the SCHED_RR scheduling policy. Higher nice values are assigned larger time quantum.

Time-Sharing Scheduling (SCHED_OTHER)

SCHED_OTHER can only be used at user priority 0. SCHED_OTHER is the default universal time-sharing scheduler policy that is intended for all processes that do not require special user priority real-time mechanisms. The process to run is chosen from the user priority 0 list based on a dynamic priority that is determined only inside this list. The dynamic priority is based on the nice level (set by the `nice(2)` or `setpriority(2)` system call) and increased for each time quantum the process is ready to run, but denied to run by the scheduler. This ensures fair progress among all SCHED_OTHER processes. Other factors, such as the number of times a process voluntarily blocks itself by performing an I/O operation, also come into consideration.

Procedures for Enhanced Performance

How to Set Priorities

The following code segment will place the current process into the SCHED_RR fixed-priority scheduling policy at a fixed priority of 60. See the section “Process Scheduling Interfaces” later in this chapter for information about the POSIX scheduling routines.

```
#include <sched.h>
...
struct sched_param sparms;

sparms.sched_priority = 60;
if (sched_setscheduler(0, SCHED_RR, &sparms) < 0)
{
    perror("sched_setsched");
    exit(1);
}
```

Interrupt Routines

Processes scheduled in one of the fixed-priority scheduling policies will be assigned a higher priority than the processing associated with softirqs and tasklets. These interrupt routines perform work on behalf of interrupt routines that have executed on a given CPU. The real interrupt routine runs at a hardware interrupt level and preempts all activity on a CPU (including processes scheduled under one of the fixed-priority scheduling policies). Device driver writers under Linux are encouraged to perform the minimum amount of work required to interact with a device to make the device believe that the interrupt has been handled. The device driver can then raise one of the interrupt mechanisms to handle the remainder of the work associated with the device interrupt routine. Because fixed-priority processes run at a priority above these interrupt routines, this interrupt architecture allows fixed-priority processes to experience the minimum amount of jitter possible from interrupt routines. For more information about interrupt routines in device drivers, see the “Device Drivers” chapter.

SCHED_FIFO vs SCHED_RR

The two fixed priority scheduling policies are very similar in their nature, and under most conditions they will behave in an identical manner. It is important to remember that while SCHED_RR has a time quantum associated with the process, when that time quantum expires the process will only yield the CPU if there currently is a ready-to-run process of equal priority in one of the fixed priority scheduling policies. If there is no ready-to-run process of equal priority, the scheduler will determine that the original SCHED_RR process is still the highest priority process ready to run on this CPU and the same process will again be selected for execution.

This means that the only time there is a difference between processes scheduled under SCHED_FIFO and SCHED_RR is when there are multiple processes running under one of the fixed-priority scheduling policies scheduled at the exact same scheduling priority. In this case, SCHED_RR will allow these processes to share a CPU according to the time quantum that has been assigned to the process. Note that a process’ time quantum is affected by the **nice(2)** system call. Processes with higher nice values will be assigned a larger time quantum. A process’ time quantum can also be changed via the **run(1)** command (see “The run Command” later in this chapter for details).

Fixed Priority Processes Locking Up a CPU

A non-blocking endless loop in a process scheduled under the SCHED_FIFO and SCHED_RR scheduling policies will block all processes with lower priority indefinitely. As this scenario can starve the CPU of other processes completely, precautions should be taken to avoid this.

During software development, a programmer can break such an endless loop by keeping available on the console a shell scheduled under a higher user priority than the tested application. This will allow an emergency kill of tested real-time applications that do not block or terminate as expected. As SCHED_FIFO and SCHED_RR processes can preempt other processes forever, only root processes or processes with the CAP_SYS_NICE capability are allowed to activate these policies.

Memory Locking

Paging and swapping often add an unpredictable amount of system overhead time to application programs. To eliminate performance losses due to paging and swapping, use the `mlockall(2)`, `munlockall(2)`, `mlock(2)` and `munlock(2)` system calls to lock all or a portion of a process' virtual address space in physical memory.

CPU Affinity and Shielded Processors

Each process in the system has a CPU affinity mask. The CPU affinity mask determines on which CPUs the process is allowed to execute. When a CPU is shielded from processes, that CPU will only run processes that have explicitly set their CPU affinity to a set of CPUs that only includes shielded CPUs. Utilizing these techniques adds additional control to where and how a process executes. See the "Real-Time Performance" chapter of this guide for more information.

Process Scheduling Interfaces

A set of system calls based on IEEE Standard 1003.1b provides direct access to a process' scheduling policy and priority. You may alter the scheduling policy and priority for a process at the command level by using the `run(1)` command. The system calls are detailed below. The `run` command is detailed on page 4-13.

POSIX Scheduling Routines

The sections that follow explain the procedures for using the POSIX scheduling system calls. These system calls are briefly described as follows:

Scheduling Policy:

`sched_setscheduler` set a process' scheduling policy and priority

`sched_getscheduler` obtain a process' scheduling policy

Scheduling Priority:

`sched_setparam` change a process' scheduling priority

`sched_getparam` obtain a process' scheduling priority

Relinquish CPU:

`sched_yield` relinquish the CPU

Low/High Priority:

sched_get_priority_min obtain the lowest priority associated with a scheduling policy

sched_get_priority_max obtain the highest priority associated with a scheduling policy

Round-Robin Policy:

sched_rr_get_interval obtain the time quantum associated with a process scheduled under the SCHED_RR scheduling policy

The sched_setscheduler Routine

The **sched_setscheduler(2)** system call allows you to set the scheduling policy and the associated parameters for the process.

It is important to note that to use the **sched_setscheduler** call to (1) change a process' scheduling policy to the SCHED_FIFO or the SCHED_RR policy or (2) change the priority of a process scheduled under the SCHED_FIFO or the SCHED_RR policy, one of the following conditions must be met:

- The calling process must have root capability.
- The effective user ID (uid) of the calling process must match the effective user ID of the target process (the process for which the scheduling policy and priority are being set), or the calling process must have superuser or CAP_SYS_NICE capability.

Synopsis

```
#include <sched.h>

int sched_setscheduler(pid_t pid, int policy, const struct sched_param *p);

struct sched_param {
    ...
    int sched_priority;
    ...
};
```

The arguments are defined as follows:

pid the process identification number (PID) of the process for which the scheduling policy and priority are being set. To specify the current process, set the value of *pid* to zero.

policy a scheduling policy as defined in the file <**sched.h**>. The value of *policy* must be one of the following:

SCHED_FIFO	first-in-first-out (FIFO) scheduling policy
SCHED_RR	round-robin (RR) scheduling policy
SCHED_OTHER	time-sharing scheduling policy

p a pointer to a structure that specifies the scheduling priority of the process identified by *pid*. The priority is an integer value that lies in the range of priorities defined for the scheduler class associated with the specified policy. You can determine the range of priorities associated with that policy by invoking one of the following system calls: **sched_get_priority_min** or **sched_get_priority_max** (for an explanation of these system calls, see page 4-11).

If the scheduling policy and priority of the specified process are successfully set, the **sched_setscheduler** system call returns the process' previous scheduling policy. A return value of -1 indicates that an error has occurred; `errno` is set to indicate the error. Refer to the **sched_setscheduler(2)** man page for a listing of the types of errors that may occur. If an error occurs, the process' scheduling policy and priority are not changed.

It is important to note that when you change a process' scheduling policy, you also change its time quantum to the default time quantum that is defined for the scheduler associated with the new policy and the priority. You can change the time quantum for a process scheduled under the SCHED_RR scheduling policy at the command level by using the **run(1)** command (see p. 4-13 for information on this command).

The sched_getscheduler Routine

The **sched_getscheduler(2)** system call allows you to obtain the scheduling policy for a specified process. Scheduling policies are defined in the file `<sched.h>` as follows:

SCHED_FIFO	first-in-first-out (FIFO) scheduling policy
SCHED_RR	round-robin (RR) scheduling policy
SCHED_OTHER	time-sharing scheduling policy

Synopsis

```
#include <sched.h>

int sched_getscheduler(pid_t pid);
```

The argument is defined as follows:

pid the process identification number (PID) of the process for which you wish to obtain the scheduling policy. To specify the current process, set the value of *pid* to zero.

If the call is successful, **sched_getscheduler** returns the scheduling policy of the specified process. A return value of -1 indicates that an error has occurred; `errno` is set to indicate the error. Refer to the **sched_getscheduler(2)** man page for a listing of the types of errors that may occur.

The sched_setparam Routine

The **sched_setparam(2)** system call allows you to set the scheduling parameters associated with the scheduling policy of a specified process.

It is important to note that to use the **sched_setparam** call to change the scheduling priority of a process scheduled under the SCHED_FIFO or the SCHED_RR policy, one of the following conditions must be met:

- The calling process must have the root capability.
- The effective user ID (euid) of the calling process must match the effective user ID of the target process (the process for which the scheduling policy and priority are being set), or the calling process must have superuser or CAP_SYS_NICE capability.

Synopsis

```
#include <sched.h>

int sched_setparam(pid_t pid, const struct sched_param *p);

struct sched_param {
    ...
    int sched_priority;
    ...
};
```

The arguments are defined as follows:

- pid* the process identification number (PID) of the process for which the scheduling priority is being changed. To specify the current process, set the value of *pid* to zero.
- p* a pointer to a structure that specifies the scheduling priority of the process identified by *pid*. The priority is an integer value that lies in the range of priorities associated with the process' current scheduling policy. High numbers represent more favorable priorities and scheduling.

You can obtain a process' scheduling policy by invoking the **sched_getscheduler(2)** system call (see p. 4-7 for an explanation of this system call). You can determine the range of priorities associated with that policy by invoking the **sched_get_priority_min(2)** and **sched_get_priority_max(2)** system calls (see page 4-11 for explanations of these system calls).

A return value of 0 indicates that the scheduling priority of the specified process has been successfully changed. A return value of -1 indicates that an error has occurred; `errno` is set to indicate the error. Refer to the **sched_setparam(2)** man page for a listing of the types of errors that may occur. If an error occurs, the process' scheduling priority is not changed.

The sched_getparam Routine

The **sched_getparam(2)** system call allows you to obtain the scheduling parameters of a specified process.

Synopsis

```
#include <sched.h>

int sched_getparam(pid_t pid, struct sched_param *p);

struct sched_param {
    ...
    int sched_priority;
    ...
};
```

The arguments are defined as follows:

- pid* the process identification number (PID) of the process for which you wish to obtain the scheduling priority. To specify the current process, set the value of *pid* to zero.
- p* a pointer to a structure to which the scheduling priority of the process identified by *pid* will be returned.

A return value of 0 indicates that the call to **sched_getparam** has been successful. The scheduling priority of the specified process is returned in the structure to which *p* points. A return value of -1 indicates that an error has occurred; `errno` is set to indicate the error. Refer to the **sched_getparam(2)** man page for a listing of the types of errors that may occur.

The sched_yield Routine

The **sched_yield(2)** system call allows the calling process to relinquish the CPU until it again becomes the highest priority process that is ready to run. Note that a call to **sched_yield** is effective only if a process whose priority is equal to that of the calling process is ready to run. This system call cannot be used to allow a process whose priority is lower than that of the calling process to execute.

Synopsis

```
#include <sched.h>

int sched_yield(void);
```

A return value of 0 indicates that the call to **sched_yield** has been successful. A return value of -1 indicates that an error has occurred; `errno` is set to indicate the error.

The sched_get_priority_min Routine

The **sched_get_priority_min(2)** system call allows you to obtain the lowest (least favorable) priority associated with a specified scheduling policy.

Synopsis

```
#include <sched.h>

int sched_get_priority_min(int policy);
```

The argument is defined as follows:

policy a scheduling policy as defined in the file **<sched.h>**. The value of *policy* must be one of the following:

SCHED_FIFO	first-in-first-out (FIFO) scheduling policy
SCHED_RR	round-robin (RR) scheduling policy
SCHED_OTHER	time-sharing scheduling policy

Processes with numerically higher priority values are scheduled before processes with numerically lower priority values. The value returned by **sched_get_priority_max** will be greater than the value returned by **sched_get_priority_min**.

RedHawk Linux allows the user priority value range 1 to 99 for SCHED_FIFO and SCHED_RR and the priority 0 for SCHED_OTHER.

If the call is successful, **sched_get_priority_min** returns the lowest priority associated with the specified scheduling policy. A return value of -1 indicates that an error has occurred; `errno` is set to indicate the error. Refer to the man page for **sched_get_priority_max(2)** to obtain a listing of the errors that may occur.

The sched_get_priority_max Routine

The **sched_get_priority_max(2)** system call allows you to obtain the highest (most favorable) priority associated with a specified scheduling policy.

Synopsis

```
#include <sched.h>

int sched_get_priority_max(int policy);
```

The argument is defined as follows:

policy a scheduling policy as defined in the file **<sched.h>**. The value of *policy* must be one of the following:

SCHED_FIFO	first-in-first-out (FIFO) scheduling policy
SCHED_RR	round-robin (RR) scheduling policy
SCHED_OTHER	time-sharing scheduling policy

Processes with numerically higher priority values are scheduled before processes with numerically lower priority values. The value returned by **sched_get_priority_max** will be greater than the value returned by **sched_get_priority_min**.

RedHawk Linux allows the user priority value range 1 to 99 for SCHED_FIFO and SCHED_RR and the priority 0 for SCHED_OTHER.

If the call is successful, `sched_get_priority_max` returns the highest priority associated with the specified scheduling policy. A return value of -1 indicates that an error has occurred; `errno` is set to indicate the error. For a listing of the types of errors that may occur, refer to the `sched_get_priority_max(2)` man page.

The `sched_rr_get_interval` Routine

The `sched_rr_get_interval(2)` system call allows you to obtain the time quantum for a process that is scheduled under the SCHED_RR scheduling policy. The time quantum is the fixed period of time for which the kernel allocates the CPU to a process. When the process to which the CPU has been allocated has been running for its time quantum, a scheduling decision is made. If another process of the same priority is ready to run, that process will be scheduled. If not, the other process will continue to run.

Synopsis

```
include <sched.h>

int sched_rr_get_interval(pid_t pid, struct timespec *tp);

struct timespec {
    time_t  tv_sec;      /* seconds */
    long    tv_nsec;    /* nanoseconds */
};
```

The arguments are defined as follows:

- pid* the process identification number (PID) of the process for which you wish to obtain the time quantum. To specify the current process, set the value of *pid* to zero.
- tp* a pointer to a `timespec` structure to which the round robin time quantum of the process identified by *pid* will be returned. The identified process should be running under the SCHED_RR scheduling policy.

A return value of 0 indicates that the call to `sched_rr_get_interval` has been successful. The time quantum of the specified process is returned in the structure to which *tp* points. A return value of -1 indicates that an error has occurred; `errno` is set to indicate the error. Refer to the `sched_rr_get_interval(2)` man page for a listing of the types of errors that may occur.

The run Command

The **run(1)** command can be used to control process scheduler attributes and CPU affinity. The command syntax is:

```
run [OPTIONS] {COMMAND [ARGS] | PROCESS/THREAD_SPECIFIER}
```

The **run** command executes the specified command in the environment described by the list of options and exits with the command's exit value. If a specifier is given, **run** modifies the environment of the set of processes/threads selected by the specifier. The specifiers are defined below. A command may not be combined with a specifier on the same command line invocation.

The **run** command allows you to run a program under a specified POSIX scheduling policy and at a specified priority (see p. 4-3 for a complete explanation of POSIX scheduling policies). It also allows you to set the time quantum for a program scheduled under the SCHED_RR policy.

To set a program's scheduling policy and priority, invoke the **run** command from the shell, and specify either the **--policy=policy** or **-s policy** option and the **--priority=priority** or **-P priority** option. Valid keywords for *policy* are:

SCHED_FIFO or fifo	for first-in-first-out scheduling
SCHED_RR or rr	for round robin scheduling, and
SCHED_OTHER or other	for timeshare scheduling.

The value of *priority* must be an integer value that is valid for the specified scheduling policy (or the current scheduling policy if the **-s** option is not used). Higher numerical values represent more favorable scheduling priorities.

To set the time quantum for a program being scheduled under the SCHED_RR scheduling policy, also specify the **--quantum=quantum** or **-q quantum** option. *quantum* is specified as a nice value between -20 and 19 inclusive, with -20 being the longest slice of time and 19 being the shortest, or as a millisecond value corresponding to a nice value. **--quantum=list** displays the nice values and their equivalent millisecond values.

You can set the CPU affinity using the **--bias=list** or **-b list** option. *list* is a comma-separated list of logical CPU numbers or ranges, for example: "0,2-4,6". *list* may also be specified as the string "active" or "boot" to specify all active processors or the boot processor, respectively. The CAP_SYS_NICE capability is required to add additional CPUs to an affinity.

The **--negate** or **-N** option negates the CPU bias list. A bias list option must also be specified when the negate option is specified. The bias used will contain all CPUs on the system except those specified in the bias list.

The **--copies=count** or **-c count** option enables the user to run the specified number of identical copies of the command.

Other options are available for displaying information and running the command in the background. Options for setting NUMA memory policies are documented in Chapter 10. See the **run(1)** man page for more information.

PROCESS/THREAD_SPECIFIER

This parameter is used to specify the processes or threads to be acted upon. Only one of the following may be specified. Multiple comma separated values can be specified for all *lists* and ranges are allowed where appropriate.

- all, -a** Specify all existing processes and threads.
- pid=list, -p list** Specify a list of existing PIDs to modify. All scheduler operations are specific to the complete set of processes listed, including all sub-threads.
- tid=list, -t list** Specify a list of existing TIDs to modify. All scheduler operations are specific to only the listed threads and not unspecified sibling threads in the process. **-l list** can be used for PowerMAX compatibility.
- group=list, -g list** Specify a list of process groups to modify; all existing processes in the process groups listed will be modified.
- user=list, -u list** Specify a list of users to modify; all existing processes owned by the users listed will be modified. Each user in the list may either be a valid numeric user ID or character login ID.
- name=list, -n list** Specify a list of existing process names to modify.

Examples

1. The following command runs **make(1)** in the background on any of CPUs 0-3 under the default SCHED_OTHER scheduling policy with default priority.

```
run --bias=0-3 make &
```

2. The following command runs **date(1)** with a priority of 10 in the SCHED_RR (i.e. Round Robin) scheduling policy.

```
run -s SCHED_RR -P 10 date
```

3. The following command changes the scheduling priority of process ID 987 to level 32.

```
run --priority=32 -p 987
```

4. The following command moves all processes in process group 1456 to CPU 3.

```
run -b 3 -g 1456
```

5. The following command sets all processes whose name is "pilot" to run in the SCHED_FIFO scheduling policy with a priority of 21.

```
run -s fifo -P 21 -n pilot
```

Refer to the **run(1)** man page for additional information.

Interprocess Synchronization

This chapter describes the tools that RedHawk Linux provides to meet a variety of interprocess synchronization needs. All of the interfaces described here provide the means for cooperating processes to synchronize access to shared resources.

The most efficient mechanism for synchronizing access to shared data by multiple programs in a multiprocessor system is by using spin locks. However, it is not safe to use a spin lock from user level without also using a rescheduling variable to protect against preemption while holding a spin lock.

If portability is a larger concern than efficiency, then POSIX counting semaphores and mutexes are the next best choice for synchronizing access to shared data. System V semaphores are also provided, which allow processes to communicate through the exchange of semaphore values. Since many applications require the use of more than one semaphore, this facility allows you to create sets or arrays of semaphores.

Problems associated with synchronizing cooperating processes' access to data in shared memory are discussed as well as the tools that have been developed by Concurrent to provide solutions to these problems.

Understanding Interprocess Synchronization

Multiprocess real-time applications require synchronization mechanisms that allow cooperating processes to coordinate access to the same set of resources—for example, a number of I/O buffers, units of a hardware device, or a critical section of code.

RedHawk Linux supplies a variety of interprocess synchronization tools. These include tools for controlling a process' vulnerability to rescheduling, serializing processes' access to critical sections with busy-wait mutual exclusion mechanisms, semaphores for mutual exclusion to critical sections and coordinating interaction among processes.

Application programs that consist of two or more processes sharing portions of their virtual address space through use of shared memory need to be able to coordinate their access to shared memory efficiently. Two fundamental forms of synchronization are used to coordinate processes' access to shared memory: *mutual exclusion* and *condition synchronization*. Mutual exclusion mechanisms serialize cooperating processes' access to shared resources. Condition synchronization mechanisms delay a process' progress until an application-defined condition is met.

Mutual exclusion mechanisms ensure that only one of the cooperating processes can be executing in a critical section at a time. Three types of mechanisms are typically used to provide mutual exclusion—those that involve busy waiting, those that involve sleepy waiting, and those that involve a combination of the two when a process attempts to enter a locked critical section. Busy-wait mechanisms, also known as *spin locks*, use a locking technique that obtains a lock using a hardware supported test and set operation. If a process attempts to obtain a busy-wait lock that is currently in a locked state, the locking

process continues to retry the test and set operation until the process that currently holds the lock has cleared it and the test and set operation succeeds. In contrast, a sleepy-wait mechanism, such as a semaphore, will put a process to sleep if it attempts to obtain a lock that is currently in a locked state.

Busy-wait mechanisms are highly efficient when most attempts to obtain the lock will succeed. This is because a simple test and set operation is all that is required to obtain a busy-wait lock. Busy-wait mechanisms are appropriate for protecting resources when the amount of time that the lock is held is short. There are two reasons for this: 1) when lock hold times are short, it is likely that a locking process will find the lock in an unlocked state and therefore the overhead of the lock mechanism will also be minimal and 2) when the lock hold time is short, the delay in obtaining the lock is also expected to be short. It is important when using busy-wait mutual exclusion that delays in obtaining a lock be kept short, since the busy-wait mechanism is going to waste CPU resources while waiting for a lock to become unlocked. As a general rule, if the lock hold times are all less than the time it takes to execute two context switches, then a busy-wait mechanism is appropriate. Tools for implementing busy-wait mutual exclusion are explained in the section “Busy-Wait Mutual Exclusion.”

Critical sections are often very short. To keep the cost of synchronization comparatively small, synchronizing operations performed on entry/exit to/from a critical section cannot enter the kernel. It is undesirable for the execution overhead associated with entering and leaving the critical section to be longer than the length of the critical section itself.

In order for spin locks to be used as an effective mutual exclusion tool, the expected time that a process will spin waiting for another process to release the lock must be not only brief but also predictable. Such unpredictable events as page faults, signals, and the preemption of a process holding the lock cause the real elapsed time in a critical section to significantly exceed the expected execution time. At best, these unexpected delays inside a critical section may cause other CPUs to delay longer than anticipated; at worst, they may cause deadlock. Locking pages in memory can be accomplished during program initialization so as not to have an impact on the time to enter a critical section. The mechanisms for rescheduling control provide a low-overhead means of controlling signals and process preemption. Tools for providing rescheduling control are described in “Rescheduling Control.”

Semaphores are another mechanism for providing mutual exclusion. Semaphores are a form of sleepy-wait mutual exclusion because a process that attempts to lock a semaphore that is already locked will be blocked or put to sleep. POSIX counting semaphores provide a portable means of controlling access to shared resources. A counting semaphore is an object that has an integer value and a limited set of operations defined for it. Counting semaphores provide a simple interface that is implemented to achieve the fastest performance for lock and unlock operations. POSIX counting semaphores are described in the section “POSIX Counting Semaphores.” System V semaphores are a complex data type that allows many additional functions (for example the ability to find out how many waiters there are on a semaphore or the ability to operate on a set of semaphores). System V semaphores are described in the section “System V Semaphores.”

Mutexes allow multiple threads in a program to share the same resource but not simultaneously. A mutex is created and any thread that needs the resource must lock the mutex from other threads while using the resource and unlock it when it is no longer needed. POSIX mutexes have two features, individually configurable on a per-mutex basis, which are especially useful for real-time applications: *robust mutexes* and *priority inheritance mutexes*. Robustness gives applications a chance to recover if one of the application's threads dies while holding a mutex. Applications using a priority inheritance

mutex can find the priority of the mutex's owner boosted from time to time. These are explained in the section "Extensions to POSIX Mutexes."

Rescheduling Control

Multiprocess, real-time applications frequently wish to defer CPU rescheduling for brief periods of time. To use busy-wait mutual exclusion effectively, spinlock hold times must be small and predictable.

CPU rescheduling and signal handling are major sources of unpredictability. A process would like to make itself immune to rescheduling when it acquires a spinlock, and vulnerable again when it releases the lock. A system call could raise the caller's priority to the highest in the system, but the overhead of doing so is prohibitive.

A rescheduling variable provides control for rescheduling and signal handling. You register the variable in your application and manipulate it directly from your application. While rescheduling is disabled, quantum expirations, preemptions, and certain types of signals are held.

A system call and a set of macros accommodate use of the rescheduling variable. In the sections that follow, the variable, the system call, and the macros are described, and the procedures for using them are explained.

The primitives described here provide low overhead control of CPU rescheduling and signal delivery.

Understanding Rescheduling Variables

A rescheduling variable is a data structure, defined in `<sys/rescnt1.h>` that controls a single process' vulnerability to rescheduling:

```
struct resched_var {
    pid_t rv_pid;
    ...
    volatile int rv_nlocks;
    ...
};
```

It is allocated on a per-process or per-thread basis by the application, not by the kernel. The `resched_cntl(2)` system call registers the variable, and the kernel examines the variable before making rescheduling decisions.

Use of the `resched_cntl` system call is explained in "Using resched_cntl System Call." A set of rescheduling control macros enables you to manipulate the variable from your application. Use of these macros is explained in "Using the Rescheduling Control Macros."

Each thread must register its own rescheduling variable. A rescheduling variable is valid only for the process or thread that registers the location of the rescheduling variable. Under the current implementation, it is recommended that rescheduling variables be used

only by single-threaded processes. Forking in a multi-threaded program that uses rescheduling variables should be avoided.

Using `resched_cntl` System Call

The `resched_cntl` system call enables you to perform a variety of rescheduling control operations. These include registering and initializing a rescheduling variable, obtaining its location, and setting a limit on the length of time that rescheduling can be deferred.

Synopsis

```
#include <sys/rescntl.h>
```

```
int resched_cntl(cmd, arg)
```

```
int cmd;
```

```
char *arg;
```

```
gcc [options] file -lccur_rt ...
```

Arguments are defined as follows:

cmd the operation to be performed

arg a pointer to an argument whose value depends upon the value of *cmd*

cmd can be one of the following. The values of *arg* that are associated with each command are indicated.

RESCHED_SET_VARIABLE

This command registers the caller's rescheduling variable. The rescheduling variable must be located in a process private page, which excludes pages in shared memory segments or files that have been mapped `MAP_SHARED`.

Two threads of the same process should not register the same address as their rescheduling variable. If *arg* is not `NULL`, the `struct resched_var` it points to is initialized and locked into physical memory. If *arg* is `NULL`, the caller is disassociated from any existing variable, and the appropriate pages are unlocked.

After a `fork(2)`, the child process inherits rescheduling variables from its parent. The `rv_pid` field of the child's rescheduling variable is updated to the process ID of the child.

If a child process has inherited a rescheduling variable and it, in turn, forks one or more child processes, those child processes inherit the rescheduling variable with the `rv_pid` field updated.

If a rescheduling variable is locked in the parent process at the time of the call to `fork`, `vfork(2)` or `clone(2)`, the rescheduling variable aborts.

	Use of this command requires root capability or CAP_IPC_LOCK and CAP_SYS_RAWIO privileges.
RESCHED_SET_LIMIT	This command is a debugging tool. If <i>arg</i> is not NULL, it points to a <code>struct timeval</code> specifying the maximum length of time the caller expects to defer rescheduling. The SIGABRT signal is sent to the caller when this limit is exceeded if the local timer of the CPU is enabled. If <i>arg</i> is NULL, any previous limit is forgotten.
RESCHED_GET_VARIABLE	This command returns the location of the caller's rescheduling variable. <i>arg</i> must point to a rescheduling variable pointer. The pointer referenced by <i>arg</i> is set to NULL if the caller has no rescheduling variable, and is set to the location of the rescheduling variable otherwise.
RESCHED_SERVE	This command is used by resched_unlock to service pending signals and context switches. Applications should not need to use this command directly. <i>arg</i> must be 0.

Using the Rescheduling Control Macros

A set of rescheduling control macros enables you to lock and unlock rescheduling variables and to determine the number of rescheduling locks in effect. These macros are briefly described as follows:

resched_lock	increments the number of rescheduling locks held by the calling process
resched_unlock	decrements the number of rescheduling locks held by the calling process
resched_nlocks	returns the number of rescheduling locks currently in effect

resched_lock

Synopsis

```
#include <sys/rescntl.h>

void resched_lock(r);

struct resched_var *r;
```

The argument is defined as follows:

r a pointer to the calling process' rescheduling variable

Resched_lock does not return a value; it increments the number of rescheduling locks held by the calling process. As long as the process does not enter the kernel, quantum expirations, preemptions, and some signal deliveries are deferred until all rescheduling locks are released.

However, if the process generates an exception (e.g., a page fault) or makes a system call, it may receive signals or otherwise context switch regardless of the number of rescheduling locks it holds. The following signals represent error conditions and are NOT affected by rescheduling locks: SIGILL, SIGTRAP, SIGFPE, SIGKILL, SIGBUS, SIGSEGV, SIGABRT, SIGSYS, SIGPIPE, SIGXCPU, and SIGXFSZ.

Making system calls while a rescheduling variable is locked is possible but not recommended. However, it is not valid to make any system call that results in putting the calling process to sleep while a rescheduling variable is locked.

resched_unlock

Synopsis

```
#include <sys/rescntl.h>
void resched_unlock(r);
struct resched_var *r;
```

The argument is defined as follows:

r a pointer to the calling process' rescheduling variable

Resched_unlock does not return a value. If there are no outstanding locks after the decrement and a context switch or signal are pending, they are serviced immediately.

NOTE

The `rv_nlocks` field must be a positive integer for the lock to be considered active. Thus, if the field is zero or negative, it is considered to be unlocked.

resched_nlocks

Synopsis

```
#include <sys/rescntl.h>
int resched_nlocks(r);
struct resched_var *r;
```

The argument is defined as follows:

r a pointer to the calling process' rescheduling variable

Resched_nlocks returns the number of rescheduling locks currently in effect.

For additional information on the use of these macros, refer to the **resched_cntl(2)** man page.

Applying Rescheduling Control Tools

The following C program segment illustrates the procedures for controlling rescheduling by using the tools described in the preceding sections. This program segment defines a rescheduling variable (`rv`) as a global variable; registers and initializes the variable with a call to `resched_cntl`; and locks and unlocks the rescheduling variables with calls to `resched_lock` and `resched_unlock`, respectively.

```
static struct resched_var rv;

int main (int argc, char *argv[])
{
    resched_cntl (RESCHED_SET_VARIABLE, (char *)&rv);

    resched_lock (&rv);

    /* nonpreemptible code */
    ...

    resched_unlock (&rv);
    return 0;
}
```

Busy-Wait Mutual Exclusion

Busy-wait mutual exclusion is achieved by associating a synchronizing variable with a shared resource. When a process or thread wishes to gain access to the resource, it locks the synchronizing variable. When it completes its use of the resource, it unlocks the synchronizing variable. If another process or thread attempts to gain access to the resource while the first process or thread has the resource locked, that process or thread must delay by repeatedly testing the state of the lock. This form of synchronization requires that the synchronizing variable be accessible directly from user mode and that the lock and unlock operations have very low overhead.

RedHawk Linux provides two types of low-overhead busy-wait mutual exclusion variables: `spin_mutex` and `nopreempt_spin_mutex`. A `nopreempt_spin_mutex` automatically uses rescheduling variables to make threads or processes non-preemptible while holding the mutex; a `spin_mutex` does not.

In the sections that follow, the variables and interfaces are defined, and the procedures for using them are explained.

Understanding the `spin_mutex` Variable

The busy-wait mutual exclusion variable is a data structure known as a spin lock. The `spin_mutex` variable is defined in `<spin.h>` as follows:

```
typedef struct spin_mutex {
    volatile int count;
} spin_mutex_t;
```

The spin lock has two states: locked and unlocked. When initialized, the spin lock is in the unlocked state.

If you wish to use spin locks to coordinate access to shared resources, you must allocate them in your application program and locate them in memory that is shared by the processes or threads that you wish to synchronize. You can manipulate them by using the interfaces described in “Using the spin_mutex Interfaces.”

Using the spin_mutex Interfaces

This set of busy-wait mutual exclusion interfaces allows you to initialize, lock, and unlock spin locks and determine whether or not a particular spin lock is locked. These are briefly described as follows:

spin_init	initialize a spin lock to the unlocked state
spin_lock	spin until the spin lock can be locked
spin_trylock	attempt to lock a specified spin lock
spin_islock	determine whether or not a specified spin lock is locked
spin_unlock	unlock a specified spin lock

It is important to note that none of these interfaces enables you to lock a spin lock unconditionally. You can construct this capability by using the tools that are provided.

CAUTION

Operations on spin locks are not recursive; a process or thread can deadlock if it attempts to relock a spin lock that it has already locked.

You must initialize spin locks before you use them by calling **spin_init**. You call **spin_init** only once for each spin lock. If the specified spin lock is locked, **spin_init** effectively unlocks it; it does not return a value. The **spin_init** interface is specified as follows:

```
#include <spin.h>
void spin_init(spin_mutex_t *m);
```

The argument is defined as follows:

m the starting address of the spin lock

spin_lock spins until the spin lock can be locked. It does not return a value. The interface is specified as follows:

```
#include <spin.h>
void spin_lock(spin_mutex_t *m);
```

spin_trylock returns true if the calling process or thread has succeeded in locking the spin lock; false if it has not succeeded. **spin_trylock** does not block the calling process or thread. The interface is specified as follows:

```
#include <spin.h>
int spin_trylock(spin_mutex_t *m);
```

spin_islock returns true if the specified spin lock is locked; false if it is unlocked. It does not attempt to lock the spin lock. The interface is specified as follows:

```
#include <spin.h>
int spin_islock(spin_mutex_t *m);
```

spin_unlock unlocks the spin lock. It does not return a value. The interface is specified as follows:

```
#include <spin.h>
void spin_unlock(spin_mutex_t *m);
```

Note that **spin_lock**, **spin_trylock** and **spin_unlock** can log trace events to be monitored by NightTrace RT. An application can enable these trace events by defining **SPIN_TRACE** prior to including **<spin.h>**. For example:

```
#define SPIN_TRACE
#include <spin.h>
```

The application must also be linked with **-lntrace**, or **-lntrace_thr** if also linked with **-lpthread**.

For additional information on the use of these interfaces, refer to the **spin_init(3)** man page.

Applying spin_mutex Tools

Procedures for using the **spin_mutex** tools for busy-wait mutual exclusion are illustrated by the following code segments. The first segment shows how to use these tools along with rescheduling control to acquire a spin lock; the second shows how to release a spin lock. Note that these segments contain no system calls or procedure calls.

The **_m** argument points to a spin lock, and the **_r** argument points to the calling process' or thread's rescheduling variable. It is assumed that the spin lock is located in shared memory. To avoid the overhead associated with paging and swapping, it is recommended that the pages that will be referenced inside the critical section be locked in physical memory (see the **mlock(2)** and **shmctl(2)** system calls).

```
#define spin_acquire(_m,_r) \
{ \
    resched_lock(_r); \
    while (!spin_trylock(_m)) { \
        resched_unlock(_r); \
        while (spin_islock(_m)); \
        resched_lock(_r); \
    } \
}
```

```

#define spin_release(_m,_r) \
{ \
    spin_unlock(_m); \
    resched_unlock(_r); \
}

```

In the first segment, note the use of the **spin_trylock** and **spin_islock** interfaces. If a process or thread attempting to lock the spin lock finds it locked, it waits for the lock to be released by calling **spin_islock**. This sequence is more efficient than polling directly with **spin_trylock**. The **spin_trylock** interface contains special instructions to perform test-and-set atomically on the spin lock. These instructions are less efficient than the simple memory read performed in **spin_islock**.

Note also the use of the rescheduling control interfaces. To prevent deadlock, a process or thread disables rescheduling prior to locking the spin lock and re-enables it after unlocking the spin lock. A process or thread also re-enables rescheduling just prior to the call to **spin_islock** so that rescheduling is not deferred any longer than necessary.

Understanding the **nopreempt_spin_mutex** Variable

The **nopreempt_spin_mutex** is a busy-wait mutex that allows multiple threads or processes to synchronize access to a shared resource. A rescheduling variable is used to make threads or processes non-preemptible while holding the mutex locked. A thread or process may safely nest the locking of multiple mutexes. The **nopreempt_spin_mutex** is defined in **<nopreempt_spin.h>** as follows:

```

typedef struct nopreempt_spin_mutex {
    spin_mutex_t spr_mux;
} nopreempt_spin_mutex_t;

```

The spin lock has two states: locked and unlocked. When initialized, the spin lock is in the unlocked state.

If you wish to use non-preemptible spin locks to coordinate access to shared resources, you must allocate them in your application program and locate them in memory that is shared by the processes or threads that you wish to synchronize. You can manipulate them by using the interfaces described in “Using the **nopreempt_spin_mutex** Interfaces.”

Using the **nopreempt_spin_mutex** Interfaces

This set of busy-wait mutual exclusion interfaces allows you to initialize, lock, and unlock non-preemptible spin locks. A rescheduling variable is used to make threads or processes non-preemptible while holding the mutex locked. These are briefly described as follows:

nopreempt_spin_init	initialize a spin lock to the unlocked state
nopreempt_spin_init_thread	guarantee that preemption can be blocked
nopreempt_spin_lock	spin until the spin lock can be locked

nopreempt_spin_trylock	attempt to lock a specified spin lock
nopreempt_spin_islock	determine whether or not a specified spin lock is locked
nopreempt_spin_unlock	unlock a specified spin lock

You must initialize spin locks before you use them by calling **nopreempt_spin_init**. You call this interface only once for each spin lock. If the specified spin lock is locked, **nopreempt_spin_init** effectively unlocks it; it does not return a value. The interface is specified as follows:

```
#include <nopreempt_spin.h>
void nopreempt_spin_init(nopreempt_spin_mutex_t *m);
```

The argument is defined as follows:

m the starting address of the spin lock

nopreempt_spin_init_thread guarantees that preemption can be blocked when **nopreempt_spin_lock** and **nopreempt_spin_trylock** are called. When a **nopreempt_spin_mutex** is used in a multi-threaded process, the process must be linked with **-lpthread** and each thread must call **nopreempt_spin_init_thread** at least once. If a process is not multi-threaded, it must call this routine at least once. This routine need only be called once regardless of how many mutexes the process or thread uses. It returns zero (0) if preemption blocking can be guaranteed; otherwise it returns -1 with **errno** set. The interface is specified as follows:

```
#include <nopreempt_spin.h>
int nopreempt_spin_init_thread(void)
```

nopreempt_spin_lock spins until the spin lock can be locked. It does not return a value. It is specified as follows:

```
#include <nopreempt_spin.h>
void nopreempt_spin_lock(nopreempt_spin_mutex_t *m);
```

nopreempt_spin_trylock returns true if the calling process or thread has succeeded in locking the spin lock; false if it has not succeeded. **nopreempt_spin_trylock** does not block the calling process or thread. The interface is specified as follows:

```
#include <nopreempt_spin.h>
int nopreempt_spin_trylock(nopreempt_spin_mutex_t *m);
```

nopreempt_spin_islock returns true if the specified spin lock is locked; false if it is unlocked. It does not attempt to lock the spin lock. The interface is specified as follows:

```
#include <nopreempt_spin.h>
int nopreempt_spin_islock(nopreempt_spin_mutex_t *m);
```

nopreempt_spin_unlock unlocks the spin lock. It does not return a value. The interface is specified as follows:

```
#include <nopreempt_spin.h>
void nopreempt_spin_unlock(nopreempt_spin_mutex_t *m);
```

Note that `nopreempt_spin_lock`, `nopreempt_spin_trylock` and `nopreempt_spin_unlock` can log trace events to be monitored by NightTrace RT. An application can enable these trace events by defining `SPIN_TRACE` prior to including `<nopreempt_spin.h>`. For example:

```
#define SPIN_TRACE
#include <nopreempt_spin.h>
```

The application must also be linked with `-lnttrace`, or `-lnttrace_thr` if also linked with `-lpthread`.

For additional information on the use of these interfaces, refer to the `nopreempt_spin_init(3)` man page.

POSIX Counting Semaphores

Overview

Counting semaphores provide a simple interface that can be implemented to achieve the fastest performance for lock and unlock operations. A counting semaphore is an object that has an integer value and a limited set of operations defined for it. These operations and the corresponding POSIX interfaces include the following:

- An initialization operation that sets the semaphore to zero or a positive value—`sem_init` or `sem_open`
- A lock operation that decrements the value of the semaphore—`sem_wait` or `sem_timedwait`. If the resulting value is negative, the task performing the operation blocks.
- An unlock operation that increments the value of the semaphore—`sem_post`. If the resulting value is less than or equal to zero, one of the tasks blocked on the semaphore is awakened. If the resulting value is greater than zero, no tasks were blocked on the semaphore.
- A conditional lock operation that decrements the value of the semaphore only if the value is positive—`sem_trywait`. If the value is zero or negative, the operation fails.
- A query operation that provides a snapshot of the value of the semaphore—`sem_getvalue`

The lock, unlock, and conditional lock operations are *atomic* (the set of operations are performed at the same time and only if they can all be performed simultaneously).

A counting semaphore may be used to control access to any resource that can be used by multiple cooperating threads. A counting semaphore can be named or unnamed.

A thread creates and initializes an *unnamed semaphore* through a call to the `sem_init(3)` routine. The semaphore is initialized to a value that is specified on the call. All threads within the application have access to the unnamed semaphore once it has been created with the `sem_init` routine call.

A thread creates a *named semaphore* by invoking the `sem_open` routine and specifying a unique name that is simply a null-terminated string. The semaphore is initialized to a value that is supplied on the call to `sem_open` to create the semaphore. No space is allocated by the process for a named semaphore because the `sem_open` routine will include the semaphore in the process's virtual address space. Other processes can gain access to the named semaphore by invoking `sem_open` and specifying the same name.

When an unnamed or named semaphore is initialized, its value should be set to the number of available resources. To use a counting semaphore to provide mutual exclusion, the semaphore value should be set to one.

A cooperating task that wants access to a critical resource must lock the semaphore that protects that resource. When the task locks the semaphore, it knows that it can use the resource without interference from any other cooperating task in the system. An application must be written so that the resource is accessed only after the semaphore that protects it has been acquired.

As long as the semaphore value is positive, resources are available for use; one of the resources is allocated to the next task that tries to acquire it. When the semaphore value is zero, then none of the resources are available; a task trying to acquire a resource must wait until one becomes available. If the semaphore value is negative, then there may be one or more tasks that are blocked and waiting to acquire one of the resources. When a task completes use of a resource, it unlocks the semaphore, indicating that the resource is available for use by another task.

The concept of ownership does not apply to a counting semaphore. One task can lock a semaphore; another task can unlock it.

The semaphore unlock operation is *async-signal safe*; that is, a task can unlock a semaphore from a signal-handling routine without causing deadlock.

The absence of ownership precludes priority inheritance. Because a task does not become the owner of a semaphore when it locks the semaphore, it cannot temporarily inherit the priority of a higher-priority task that blocks trying to lock the same semaphore. As a result, unbounded priority inversion can occur.

Interfaces

The sections that follow explain the procedures for using the POSIX counting semaphore interfaces. These interfaces are briefly described as follows:

<code>sem_init</code>	initializes an unnamed counting semaphore
<code>sem_destroy</code>	removes an unnamed counting semaphore
<code>sem_open</code>	creates, initializes and establishes a connection to a named counting semaphore
<code>sem_close</code>	relinquishes access to a named counting semaphore
<code>sem_unlink</code>	removes the name of a named counting semaphore
<code>sem_wait</code>	locks a counting semaphore
<code>sem_trywait</code>	locks a counting semaphore only if it is currently unlocked
<code>sem_timedwait</code>	locks a counting semaphore with timeout
<code>sem_post</code>	unlocks a counting semaphore
<code>sem_getvalue</code>	obtains the value of a counting semaphore

Note that to use these interfaces, you must link your application with the pthreads library. The following example shows the command line invocation when linking dynamically with shared libraries. The Native POSIX Threads Library (NPTL) is used by default.

```
gcc [options] file.c -lpthread
```

The same application can be built statically with the following invocation line. This uses the LinuxThreads library.

```
gcc [options] -static file.c -lpthread
```

Note that there is no support for process shared semaphores in the LinuxThreads library.

The sem_init Routine

The **sem_init(3)** library routine allows the calling process to initialize an unnamed counting semaphore by setting the semaphore value to the number of available resources being protected by the semaphore. To use a counting semaphore for mutual exclusion, the process sets the value to one.

Dynamically linked programs, which use the NPTL threads library, can share a semaphore across processes when the *pshared* parameter is set to a non-zero value. If *pshared* is set to zero, the semaphore is shared only among threads within the same process.

Statically linked programs, which use the LinuxThreads library, can only have counting semaphores shared among threads within the same process (*pshared* must be set to 0). After one thread in a process creates and initializes a semaphore, other cooperating threads within that same process can operate on the semaphore. A child process created by a **fork(2)** system call does *not* inherit access to a semaphore that has already been initialized by the parent. A process also loses access to a semaphore after invoking the **exec(3)** or **exit(2)** system calls.

The **sem_wait**, **sem_timedwait**, **sem_trywait**, **sem_post** and **sem_getvalue** library routines are used to operate on the semaphores. An unnamed counting semaphore is removed by invoking the **sem_destroy** routine. These routines are described in the sections that follow.

CAUTION

The IEEE 1003.1b-1993 standard does not indicate what happens when multiple processes invoke **sem_init** for the same semaphore. Currently, the RedHawk Linux implementation simply reinitializes the semaphore to the value specified on **sem_init** calls that are made after the initial **sem_init** call.

To be certain that application code can be ported to any system that supports POSIX interfaces (including future Concurrent systems), cooperating processes that use **sem_init** should ensure that a single process initializes a particular semaphore and that it does so only once.

If **sem_init** is called after it has already been initialized with a prior **sem_init** call, and there are currently threads that are waiting on this same semaphore, then these threads will never return from their **sem_wait** calls, and they will need to be explicitly terminated.

Synopsis

```
#include <semaphore.h>
int sem_init(sem_t *sem, int pshared, unsigned int value);
```

The arguments are defined as follows:

<i>sem</i>	a pointer to a <code>sem_t</code> structure that represents the unnamed counting semaphore to be initialized
<i>pshared</i>	an integer value that indicates whether or not the semaphore is to be shared by other processes. If <i>pshared</i> is set to a non-zero value, then the semaphore is shared among processes. If <i>pshared</i> is set to zero, then the semaphore is shared only among threads within the same process. Statically linked programs, which use the LinuxThreads library, cannot use semaphores shared between processes and must have <i>pshared</i> set to zero; if not set to zero, <code>sem_init</code> returns with <code>-1</code> and <code>errno</code> is set to <code>ENOSYS</code> .
<i>value</i>	zero or a positive integer value that initializes the semaphore value to the number of resources currently available. This number cannot exceed the value of <code>SEM_VALUE_MAX</code> (see the file <code><semaphore.h></code> to determine this value).

A return value of 0 indicates that the call to `sem_init` has been successful. A return value of `-1` indicates that an error has occurred; `errno` is set to indicate the error. Refer to the `sem_init(3)` man page for a listing of the types of errors that may occur.

The sem_destroy Routine**CAUTION**

An unnamed counting semaphore should not be removed until there is no longer a need for any process to operate on the semaphore and there are no processes currently blocked on the semaphore.

Synopsis

```
#include <semaphore.h>
int sem_destroy(sem_t *sem);
```

The argument is defined as follows:

<i>sem</i>	a pointer to the unnamed counting semaphore to be removed. Only a counting semaphore created with a call to <code>sem_init(3)</code> may be removed by invoking <code>sem_destroy</code> .
------------	--

A return value of 0 indicates that the call to `sem_destroy` has been successful. A return value of `-1` indicates that an error has occurred; `errno` is set to indicate the error. Refer to the `sem_destroy(3)` man page for a listing of the types of errors that may occur.

The `sem_open` Routine

The `sem_open(3)` library routine allows the calling process to create, initialize, and establish a connection to a named counting semaphore. When a process creates a named counting semaphore, it associates a unique name with the semaphore. It also sets the semaphore value to the number of available resources being protected by the semaphore. To use a named counting semaphore for mutual exclusion, the process sets the value to one.

After a process creates a named semaphore, other processes can establish a connection to that semaphore by invoking `sem_open` and specifying the same name. Upon successful completion, the `sem_open` routine returns the address of the named counting semaphore. A process subsequently uses that address to refer to the semaphore on calls to `sem_wait`, `sem_trywait`, and `sem_post`. A process may continue to operate on the named semaphore until it invokes the `sem_close` routine or the `exec(2)` or `_exit(2)` system calls. On a call to `exec` or `exit`, a named semaphore is closed as if by a call to `sem_close`. A child process created by a `fork(2)` system call inherits access to a named semaphore to which the parent process has established a connection.

If a single process makes multiple calls to `sem_open` and specifies the same name, the same address will be returned on each call unless (1) the process itself has closed the semaphore through intervening calls to `sem_close` or (2) some process has removed the name through intervening calls to `sem_unlink`.

If multiple processes make calls to `sem_open` and specify the same name, the address of the same semaphore object will be returned on each call unless some process has removed the name through intervening calls to `sem_unlink`. (Note that the same address will not necessarily be returned on each call.) If a process has removed the name through an intervening call to `sem_unlink`, the address of a new instance of the semaphore object will be returned.

Synopsis

```
#include <semaphore.h>

sem_t *sem_open(const char *name, int oflag[, mode_t mode,
unsigned int value ]);
```

The arguments are defined as follows:

- | | |
|--------------|---|
| <i>name</i> | a null-terminated string that specifies the name of a semaphore. The prefix “sem.” is prepended to <i>name</i> and the semaphore will appear as a data file in <code>/dev/shm</code> . A leading slash (/) character is allowed (recommended for portable applications) but no embedded slashes. Neither a leading slash character nor the current working directory affects interpretations of it; e.g., <code>/mysem</code> and <code>mysem</code> are both interpreted as <code>/dev/shm/sem.mysem</code> . Note that this string, including the 4-character prefix, must consist of less than <code>{NAME_MAX}</code> , defined in <code>/usr/include/limits.h</code> . |
| <i>oflag</i> | an integer value that indicates whether the calling process is creating a named counting semaphore or establishing a connection to an existing one. The following bits may be set: |

O_CREAT causes the counting semaphore specified by *name* to be created if it does not exist. The semaphore's user ID is set to the effective user ID of the calling process; its group ID is set to the effective group ID of the calling process; and its permission bits are set as specified by the *mode* argument. The semaphore's initial value is set as specified by the *value* argument. Note that you must specify both the *mode* and the *value* arguments when you set this bit.

If the counting semaphore specified by *name* exists, setting O_CREAT has no effect except as noted for O_EXCL.

O_EXCL causes **sem_open** to fail if O_CREAT is set and the counting semaphore specified by *name* exists. If O_CREAT is not set, this bit is ignored.

Note that the **sem_open** routine returns an error if flag bits other than O_CREAT and O_EXCL are set in the *oflag* argument.

mode an integer value that sets the permission bits of the counting semaphore specified by *name* with the following exception: bits set in the process's file mode creation mask are cleared in the counting semaphore's mode (refer to the **umask(2)** and **chmod(2)** man pages for additional information). If bits other than the permission bits are set in *mode*, they are ignored. A process specifies the *mode* argument only when it is creating a named counting semaphore.

value zero or a positive integer value that initializes the semaphore value to the number of resources currently available. This number cannot exceed the value of SEM_VALUE_MAX defined in the file `<limits.h>`. A process specifies the *value* argument only when it is creating a named counting semaphore.

If the call is successful, **sem_open** returns the address of the named counting semaphore. A return value of SEM_FAILED indicates that an error has occurred; `errno` is set to indicate the error. Refer to the **sem_open(3)** man page for a listing of the types of errors that may occur.

The sem_close Routine

The **sem_close(3)** library routine allows the calling process to relinquish access to a named counting semaphore. The **sem_close** routine frees the system resources that have been allocated for the process' use of the semaphore. Subsequent attempts by the process to operate on the semaphore may result in delivery of a SIGSEGV signal.

The count associated with the semaphore is not affected by a process' call to **sem_close**.

Synopsis

```
#include <semaphore.h>

int sem_close(sem_t *sem);
```

The argument is defined as follows:

sem a pointer to the named counting semaphore to which access is to be relinquished. Only a counting semaphore to which a connection has been established through a call to **sem_open(3)** may be specified.

A return value of 0 indicates that the call to **sem_close** has been successful. A return value of -1 indicates that an error has occurred; `errno` is set to indicate the error. Refer to the **sem_close(3)** man page for a listing of the types of errors that may occur.

The **sem_unlink** Routine

The **sem_unlink(3)** library routine allows the calling process to remove the name of a counting semaphore. A process that subsequently attempts to establish a connection to the semaphore by using the same name will establish a connection to a different instance of the semaphore. A process that has a reference to the semaphore at the time of the call may continue to use the semaphore until it invokes **sem_close(3)** or the **exec(2)** or **exit(2)** system call.

Synopsis

```
#include <semaphore.h>

int sem_unlink(const char *name);
```

The argument is defined as follows:

name a null-terminated string that specifies the name of a semaphore. The prefix "sem." is prepended to *name* and the semaphore will appear as a data file in **/dev/shm**. A leading slash (/) character is allowed (recommended for portable applications) but no embedded slashes. Neither a leading slash character nor the current working directory affects interpretations of it; e.g., **/mysem** and **mysem** are both interpreted as **/dev/shm/sem.mysem**. Note that this string, including the 4-character prefix, must consist of less than `{NAME_MAX}`, defined in **/usr/include/limits.h**.

A return value of 0 indicates that the call to **sem_unlink** has been successful. A return value of -1 indicates that an error has occurred; `errno` is set to indicate the error. Refer to the **sem_unlink(3)** man page for a listing of the types of errors that may occur.

The `sem_wait` Routine

The `sem_wait(3)` library routine allows the calling process to lock an unnamed counting semaphore. If the semaphore value is equal to zero, the semaphore is already locked. In this case, the process blocks until it is interrupted by a signal or the semaphore is unlocked. If the semaphore value is greater than zero, the process locks the semaphore and proceeds. In either case, the semaphore value is decremented.

Synopsis

```
#include <semaphore.h>
int sem_wait(sem_t *sem);
```

The argument is defined as follows:

sem a pointer to the unnamed counting semaphore to be locked

A return value of 0 indicates that the process has succeeded in locking the specified semaphore. A return value of -1 indicates that an error has occurred; `errno` is set to indicate the error. Refer to the `sem_wait(3)` man page for a listing of the types of errors that may occur.

The `sem_timedwait` Routine

The `sem_timedwait(3)` library routine allows the calling process to lock an unnamed counting semaphore; however, if the semaphore cannot be locked without waiting for another process or thread to unlock it via `sem_post`, the wait is terminated when the specified timeout expires.

Synopsis

```
#include <semaphore.h>
#include <time.h>
int sem_timedwait(sem_t *sem, const struct timespec *ts);
```

The arguments are defined as follows:

sem a pointer to the unnamed counting semaphore to be locked

ts a pointer to a `timespec` structure defined in `<time.h>` which specifies a single time value in seconds and nanoseconds when the wait is terminated. For example:

```
ts.tv_sec = (NULL)+2
ts.tv_nsec = 0
```

establishes a two second timeout. For more information on POSIX time structures, see “Understanding the POSIX Time Structures” in Chapter 6.

A return value of 0 indicates that the process has succeeded in locking the specified semaphore. A return value of -1 indicates that an error has occurred; `errno` is set to indicate the error. Refer to the `sem_wait(3)` man page for a listing of the types of errors that may occur.

The `sem_trywait` Routine

The `sem_trywait(3)` library routine allows the calling process to lock a counting semaphore only if the semaphore value is greater than zero, indicating that the semaphore is unlocked. If the semaphore value is equal to zero, the semaphore is already locked, and the call to `sem_trywait` fails. If a process succeeds in locking the semaphore, the semaphore value is decremented; otherwise, it does not change.

Synopsis

```
#include <semaphore.h>

int sem_trywait(sem_t *sem);
```

The argument is defined as follows:

sem a pointer to the unnamed counting semaphore that the calling process is attempting to lock

A return value of 0 indicates that the calling process has succeeded in locking the specified semaphore. A return value of -1 indicates that an error has occurred; `errno` is set to indicate the error. Refer to the `sem_trywait(3)` man page for a listing of the types of errors that may occur.

The `sem_post` Routine

The `sem_post(3)` library routine allows the calling process to unlock a counting semaphore. If one or more processes are blocked waiting for the semaphore, the waiting process with the highest priority is awakened when the semaphore is unlocked.

Synopsis

```
#include <semaphore.h>

int sem_post(sem_t *sem);
```

The argument is defined as follows:

sem a pointer to the unnamed counting semaphore to be unlocked

A return value of 0 indicates that the call to `sem_post` has been successful. If a bad semaphore descriptor has been supplied, a segmentation fault results. A return value of -1 indicates that an error has occurred; `errno` is set to indicate the error. Refer to the `sem_post(3)` man page for a listing of the types of errors that may occur.

The `sem_getvalue` Routine

The `sem_getvalue(3)` library routine allows the calling process to obtain the value of an unnamed counting semaphore.

Synopsis

```
#include <semaphore.h>

int sem_getvalue(sem_t *sem, int *sval);
```

The arguments are defined as follows:

<i>sem</i>	a pointer to the unnamed counting semaphore for which you wish to obtain the value
<i>sval</i>	a pointer to a location where the value of the specified unnamed counting semaphore is to be returned. The value that is returned represents the actual value of the semaphore at some unspecified time during the call. It is important to note, however, that this value may not be the actual value of the semaphore at the time of the return from the call.

A return value of 0 indicates that the call to `sem_getvalue` has been successful. A return value of -1 indicates that an error has occurred; `errno` is set to indicate the error. Refer to the `sem_getvalue(3)` man page for a listing of the types of errors that may occur.

Extensions to POSIX Mutexes

A mutex is a mutual exclusion device useful for protecting shared data structures from concurrent modifications and implementing critical sections. A mutex has two possible states: unlocked (not owned by any thread) and locked (owned by one thread). A thread attempting to lock a mutex that is already locked by another thread is suspended until the owning thread unlocks the mutex first.

The standard POSIX pthread mutex functionality available in RedHawk includes the following services. For full information about these services refer to the man pages.

<code>pthread_mutex_init(3)</code>	initializes the mutex
<code>pthread_mutex_lock(3)</code>	locks the mutex
<code>pthread_mutex_trylock(3)</code>	tries to lock the mutex
<code>pthread_mutex_unlock(3)</code>	unlocks the mutex
<code>pthread_mutex_destroy(3)</code>	destroys the mutex
<code>pthread_mutexattr_init(3)</code>	initializes the mutex attribute object
<code>pthread_mutexattr_destroy(3)</code>	destroys the mutex attribute object
<code>pthread_mutexattr_settype(3)</code>	sets the mutex attribute type
<code>pthread_mutexattr_gettype(3)</code>	retrieves the mutex attribute type

In addition to those services, RedHawk includes the following POSIX pthread extensions that provide robustness and priority inheritance. *Robustness* gives applications a chance to recover if one of the application's threads dies while holding a mutex. *Priority inheritance* is the automatic boosting of the scheduling priority of a thread to the priority of the highest priority thread that is sleeping, directly or indirectly, on any of the mutexes owned by that thread. These conditions are discussed in more detail below.

The services are described in the sections that follow and in the man pages.

<code>pthread_mutex_consistent_np(3)</code>	makes an inconsistent mutex consistent
<code>pthread_mutex_getunlock_np(3)</code>	returns the unlocking policy of the mutex
<code>pthread_mutex_setconsistency_np(3)</code>	sets the consistency state of the mutex
<code>pthread_mutex_setunlock_np(3)</code>	sets the unlocking policy of the mutex
<code>pthread_mutexattr_getfast_np(3)</code>	returns the operating mode
<code>pthread_mutexattr_getprotocol(3)</code>	returns the protocol
<code>pthread_mutexattr_getrobust_np(3)</code>	returns the robust level
<code>pthread_mutexattr_getunlock_np(3)</code>	returns the unlocking policy
<code>pthread_mutexattr_setfast_np(3)</code>	sets the operating mode
<code>pthread_mutexattr_setprotocol(3)</code>	sets the protocol
<code>pthread_mutexattr_setrobust_np(3)</code>	sets the robust level
<code>pthread_mutexattr_setunlock_np(3)</code>	sets the unlocking policy

Robust Mutexes

Applications using a robust mutex can detect whether the previous owner of the mutex terminated while holding the mutex. The new owner can then attempt to clean up the state protected by the mutex, and if able to do so, mark the mutex as again healthy. If cleanup of the state can't be done, the mutex can be marked unrecoverable so that any future attempts to lock it will get a status indicating that it is unrecoverable.

To implement this, two new `errno` codes, `EOWNERDEAD` and `ENOTRECOVERABLE`, are available. When a thread dies while holding a mutex, the mutex is automatically unlocked and marked dead. A dead lock operates like a normal lock except that each successful lock on a dead mutex returns an `EOWNERDEAD` error rather than success.

Therefore an application that is interested in robustness must examine the return status of every lock request. When `EOWNERDEAD` is seen, the application can ignore it, repair whatever is wrong in the application due to the death of the owner and mark it consistent (healthy), or if it cannot be repaired, mark it unrecoverable.

A mutex marked unrecoverable rejects all future operations on that mutex with an `ENOTRECOVERABLE` error. The only exception is the service which re-initializes the mutex and the services that inquire about the mutex state. Threads that were sleeping on a mutex that becomes unrecoverable wake up immediately with an `ENOTRECOVERABLE` error.

Priority Inheritance

An application using a priority inheritance mutex can find its priority temporarily boosted from time to time. The boosting happens to those threads that have acquired a mutex and other higher priority threads go to sleep waiting for that mutex. In this case, the priority of the sleeper is temporarily transferred to the lock owner for as long as that owner holds the lock.

As these sleeping threads in turn could own other mutexes, and thus themselves have boosted priorities, the `max` function takes care to use the sleeper's boosted, not base, priorities in making its decision on what priority to boost to.

User Interface

Full descriptions of the services listed here are provided in the sections that follow and on the corresponding online man page.

The following services operate on the state of the mutex:

<code>pthread_mutex_consistent_np(3)</code>	makes an inconsistent mutex consistent
<code>pthread_mutex_getunlock_np(3)</code>	returns the unlocking policy of the mutex
<code>pthread_mutex_setconsistency_np(3)</code>	sets the consistency state of the mutex
<code>pthread_mutex_setunlock_np(3)</code>	sets the unlocking policy of the mutex

The services listed below modify or make inquires about attributes stored in mutex attribute objects. A *mutex attribute object* is a data structure that defines which mutex features are to be available in mutexes created with that attribute object. Since mutexes have a lot of features, a mutex attribute object makes it convenient for an application to define all the desired attributes in one mutex attribute object, then create all the mutexes that are to have that set of attributes with that object.

In addition, those attributes which must be fixed for the life of the mutex are definable only through a mutex attribute object. Likewise, attributes which can be changed during the life of a mutex can be given an initial definition through the mutex attribute object, then can be changed later via an equivalent attribute operation on the mutex itself.

To return an attribute:

<code>pthread_mutexattr_getfast_np(3)</code>	returns the operating mode
<code>pthread_mutexattr_getprotocol(3)</code>	returns the protocol
<code>pthread_mutexattr_getrobust_np(3)</code>	returns the robust level
<code>pthread_mutexattr_getunlock_np(3)</code>	returns the unlocking policy

To set an attribute:

<code>pthread_mutexattr_setfast_np(3)</code>	sets the operating mode
<code>pthread_mutexattr_setprotocol(3)</code>	sets the protocol
<code>pthread_mutexattr_setrobust_np(3)</code>	sets the robust level
<code>pthread_mutexattr_setunlock_np(3)</code>	sets the unlocking policy

pthread_mutex_consistent_np

This service makes an inconsistent mutex consistent.

Synopsis

```
int pthread_mutex_consistent_np (pthread_mutex_t *mutex)
```

A consistent mutex becomes inconsistent if its owner dies while holding it. In addition, on detection of the death of the owner, the mutex becomes unlocked, much as if a **pthread_mutex_unlock** was executed on it. The lock continues to operate as normal, except that subsequent owners receive an EOWNERDEAD error return from the **pthread_mutex_lock** that gave it ownership. This indicates to the new owner that the acquired mutex is inconsistent.

This service can only be called by the owner of the inconsistent mutex.

pthread_mutex_getunlock_np

This service returns the unlocking policy of this mutex.

```
int pthread_mutex_getunlock_np(const pthread_mutex_t *mutex,
                              int *policy)
```

The unlocking policy is returned in *policy*, which may be set to:

PTHREAD_MUTEX_UNLOCK_SERIAL_NP

pthread_mutex_unlock is to pass the lock directly from the owner to the highest priority thread waiting for the lock.

PTHREAD_MUTEX_UNLOCK_PARALLEL_NP

The lock is unlocked and, if there are waiters, the most important of them is awakened. The awakened thread contends for the lock as it would if trying to acquire the lock for the first time.

PTHREAD_MUTEX_UNLOCK_AUTO_NP

Select between the above two policies based on the POSIX scheduling policy of the to-be-awakened thread. If the thread is SCHED_OTHER, use the parallel policy; otherwise use the serial policy.

pthread_mutex_setconsistency_np

This service sets the consistency state of the given mutex.

```
int pthread_mutex_setconsistency_np(pthread_mutex_t *mutex,
                                    int state)
```

state may be any one of the following:

PTHREAD_MUTEX_ROBUST_CONSISTENT_NP

Make an inconsistent mutex consistent. An application should do this only if it has been able to fix the problems that caused the mutex to be marked inconsistent.

PTHREAD_MUTEX_ROBUST_NOTRECOVERABLE_NP

Mark an inconsistent mutex as unrecoverable. An application should do this if it is not able to fix the problems that caused the mutex to be marked inconsistent.

The mutex must originally be in an inconsistent state or this service returns an error. Only the owner of the mutex can change its consistency state.

pthread_mutex_setunlock_np

This service sets the unlocking policy of this mutex.

Synopsis

```
int pthread_mutex_setunlock_np(pthread_mutex_t *mutex, int policy)
```

policy may be PTHREAD_MUTEX_UNLOCK_SERIAL_NP, PTHREAD_MUTEX_UNLOCK_PARALLEL_NP or PTHREAD_MUTEX_UNLOCK_AUTO_NP. Refer to the section “pthread_mutex_getunlock_np” above for definitions.

pthread_mutexattr_getfast_np

This service returns whether mutexes initialized with the set of attributes in *attr* will run in fast or in slow mode.

Synopsis

```
int pthread_mutexattr_getfast_np(const pthread_mutexattr_t *attr,
int *mode)
```

The answer is returned in *mode*, which will be set to:

PTHREAD_MUTEX_FASTPATH_NP

Mutexes initialized with *attr* will run in fast mode. In this mode, uncontended locks and unlocks do not enter the kernel.

PTHREAD_MUTEX_SLOWPATH_NP

Mutexes initialized with *attr* will run in slow mode. In this mode, the kernel is entered for every **pthread_mutex_lock** and **pthread_mutex_unlock**.

pthread_mutexattr_getprotocol

This service returns the protocol for mutexes initialized with this set of attributes.

Synopsis

```
int pthread_mutexattr_getprotocol(pthread_mutexattr_t *attr,
int *protocol)
```

The available protocols are:

PTHREAD_PRIO_NONE A thread’s scheduling priority is not affected by operations on this mutex.

PTHREAD_PRIO_INHERIT

A thread's scheduling priority is changed according to the rules of the priority inheritance protocol: as long as the thread is the owner of the mutex, it will inherit the priority of the highest priority waiter that is directly or indirectly waiting to acquire the mutex.

pthread_mutexattr_getrobust_np

This service returns the robust level for mutexes initialized with this set of attributes.

Synopsis

```
int pthread_mutexattr_getrobust_np(const pthread_mutexattr_t
    *attr, int *robustness)
```

The available levels are:

PTHREAD_MUTEX_ROBUST_NP Mutexes created with this attribute object will be robust.

PTHREAD_MUTEX_STALLED_NP Mutexes created with this attribute object will not be robust.

A robust mutex is one that detects when its owner dies and transitions to the inconsistent state. See “pthread_mutex_consistent_np” for the definition of the inconsistent state.

A nonrobust mutex does not detect when its owner dies and so remains locked indefinitely (that is, until it is interrupted by a signal or some other thread unlocks the mutex on behalf of the dead process).

pthread_mutexattr_getunlock_np

This service returns the unlocking policy for mutexes initialized with this set of attributes.

```
int pthread_mutexattr_getunlock_np(const pthread_mutexattr_t
    *attr, int *mode)
```

The available policies are PTHREAD_MUTEX_UNLOCK_SERIAL_NP, PTHREAD_MUTEX_UNLOCK_PARALLEL_NP and PTHREAD_MUTEX_UNLOCK_AUTO_NP. See the section “pthread_mutex_getunlock_np” for their definitions.

pthread_mutexattr_setfast_np

This service sets the operating mode for mutexes created with this set of attributes.

Synopsis

```
int pthread_mutexattr_setfast_np(pthread_mutexattr_t *attr,
    int mode)
```

mode may be PTHREAD_MUTEX_FASTPATH_NP or PTHREAD_MUTEX_SLOWPATH_NP. See the section “pthread_mutexattr_getfast_np” for their definitions.

pthread_mutexattr_setprotocol

This service sets the protocol of any mutex that is created from this set of mutex attributes.

Synopsis

```
int pthread_mutexattr_setprotocol(pthread_mutexattr_t *attr,
                                  int protocol)
```

protocol may be `PTHREAD_PRIO_NONE` or `PTHREAD_PRIO_INHERIT`. See the section “pthread_mutexattr_getprotocol” for their definitions.

pthread_mutexattr_setrobust_np

This service sets the robust level for mutexes that are created with this mutex attribute object.

Synopsis

```
int pthread_mutexattr_setrobust_np(pthread_mutexattr_t *attr,
                                    int robustness)
```

robustness may be `PTHREAD_MUTEX_ROBUST_NP` or `PTHREAD_MUTEX_STALLED_NP`. See “pthread_mutexattr_getrobust_np” for definitions.

pthread_mutexattr_setunlock_np

This service sets the unlocking mode for mutexes that are created with this mutex attribute object.

```
int pthread_mutexattr_setunlock_np(pthread_mutexattr_t *attr,
                                    int mode)
```

mode may be `PTHREAD_MUTEX_UNLOCK_SERIAL_NP`, `PTHREAD_MUTEX_UNLOCK_PARALLEL_NP`, or `PTHREAD_MUTEX_UNLOCK_AUTO_NP`. See the section “pthread_mutex_getunlock_np” for their definitions.

Compiling Programs with POSIX Mutexes

Programs that use priority inheritance and/or robust mutexes described above are compiled with the standard `cc(1)`, `gcc(1)` and `g++(1)` tools.

Note that previous versions of RedHawk included an alternative `glibc` that provided extensions for these mutexes, accessed by compiling and linking applications with `ccur-gcc` or `ccur-g++`. This functionality is now included in standard `glibc`; the alternative `glibc` and the `ccur-*` compilation scripts are no longer available.

The standard `glibc` additions are completely binary compatible with the extensions provided through the alternative `glibc`. Existing binaries that were compiled with `ccur-gcc` and `ccur-g++` on previous versions of RedHawk will continue to work unmodified on the current RedHawk version. Existing programs that use priority inheritance and/or robust mutexes can be compiled with the standard tools; no source changes are required. However, note that Makefiles that specify `ccur-*` need to be changed to use the standard tools. Alternatively, symbolic links can be created in `/usr/bin` to point the names `ccur-gcc` and `ccur-g++` to `gcc` and `g++`, respectively.

System V Semaphores

Overview

The System V semaphore is an interprocess communication (IPC) mechanism that allows processes to synchronize via the exchange of semaphore values. Since many applications require the use of more than one semaphore, the operating system has the ability to create sets or arrays of semaphores. A semaphore set can contain one or more semaphores, up to a limit of SEMMSL (as defined in `<linux/sem.h>`). Semaphore sets are created using the `semget(2)` system call.

When only a simple semaphore is needed, a counting semaphore is more efficient (see the section “POSIX Counting Semaphores”).

The process performing the `semget` system call becomes the owner/creator, determines how many semaphores are in the set, and sets the initial operation permissions for all processes, including itself. This process can subsequently relinquish ownership of the set or change the operation permissions using the `semctl(2)` system call. The creating process always remains the creator as long as the facility exists. Other processes with permission can use `semctl` to perform other control functions.

Any process can manipulate the semaphore(s) if the owner of the semaphore grants permission. Each semaphore within a set can be incremented and decremented with the `semop(2)` system call (see the section “The semop System Call” later in this chapter).

To increment a semaphore, an integer value of the desired magnitude is passed to the `semop` system call. To decrement a semaphore, a minus (-) value of the desired magnitude is passed.

The operating system ensures that only one process can manipulate a semaphore set at any given time. Simultaneous requests are performed sequentially in an arbitrary manner.

A process can test for a semaphore value to be greater than a certain value by attempting to decrement the semaphore by one more than that value. If the process is successful, the semaphore value is greater than that certain value. Otherwise, the semaphore value is not. While doing this, the process can have its execution suspended (IPC_NOWAIT flag not set) until the semaphore value would permit the operation (other processes increment the semaphore), or the semaphore facility is removed.

The ability to suspend execution is called a *blocking semaphore operation*. This ability is also available for a process which is testing for a semaphore equal to zero; only read permission is required for this test; it is accomplished by passing a value of zero to the `semop` system call.

On the other hand, if the process is not successful and did not request to have its execution suspended, it is called a *nonblocking semaphore operation*. In this case, the process is returned -1 and the external `errno` variable is set accordingly.

The blocking semaphore operation allows processes to synchronize via the values of semaphores at different points in time. Remember also that IPC facilities remain in the operating system until removed by a permitted process or until the system is reinitialized.

When a set of semaphores is created, the first semaphore in the set is semaphore number zero. The last semaphore number in the set is numbered one less than the total in the set.

A single system call can be used to perform a sequence of these blocking/nonblocking operations on a set of semaphores. When performing a sequence of operations, the blocking/nonblocking operations can be applied to any or all of the semaphores in the set. Also, the operations can be applied in any order of semaphore number. However, no operations are done until they can all be done successfully. For example, if the first three of six operations on a set of ten semaphores could be completed successfully, but the fourth operation would be blocked, no changes are made to the set until all six operations can be performed without blocking. Either all of the operations are successful and the semaphores are changed, or one or more (nonblocking) operation is unsuccessful and none are changed. In short, the operations are performed atomically.

Remember, any unsuccessful nonblocking operation for a single semaphore or a set of semaphores causes immediate return with no operations performed at all. When this occurs, -1 is returned to the process, and the external variable `errno` is set accordingly.

System calls make these semaphore capabilities available to processes. The calling process passes arguments to a system call, and the system call either successfully or unsuccessfully performs its function. If the system call is successful, it performs its function and returns the appropriate information. Otherwise, -1 is returned to the process, and the external variable `errno` is set accordingly.

Using System V Semaphores

Before semaphores can be used (operated on or controlled) a uniquely identified data structure and semaphore set (array) must be created. The unique identifier is called the semaphore set identifier (*semid*); it is used to identify or refer to a particular data structure and semaphore set. This identifier is accessible by any process in the system, subject to normal access restrictions.

The semaphore set contains a predefined number of structures in an array, one structure for each semaphore in the set. The number of semaphores (*nsems*) in a semaphore set is user selectable.

The `sembuf` structure, which is used on `semop(2)` system calls, is shown in Figure 5-1.

Figure 5-1 Definition of `sembuf` Structure

```
struct sembuf {
    unsigned short int sem_num; /* semaphore number */
    short int sem_op;          /* semaphore operation */
    short int sem_flg;        /* operation flag */
};
```

The `sembuf` structure is defined in the `<sys/sem.h>` header file.

The struct `semid_ds` structure, which is used on certain `semctl(2)` service calls, is shown in Figure 5-2.

Figure 5-2 Definition of `semid_ds` Structure

```

struct semid_ds {
    struct ipc_perm sem_perm;           /* operation permission struct */
    __time_t sem_otime;                 /* last semop() time */
    unsigned long int __unused1;
    __time_t sem_ctime;                 /* last time changed by semctl() */
    unsigned long int __unused2;
    unsigned long int sem_nsems;        /* number of semaphores in set */
    unsigned long int __unused3;
    unsigned long int __unused4;
};

```

Though the `semid_ds` data structure is located in `<bits/sem.h>`, user applications should include the `<sys/sem.h>` header file, which internally includes the `<bits/sem.h>` header file.

Note that the `sem_perm` member of this structure is of type `ipc_perm`. This data structure is the same for all IPC facilities; it is located in the `<bits/ipc.h>` header file, but user applications should include the `<sys/ipc.h>` file, which internally includes the `<bits/ipc.h>` header file. The details of the `ipc_perm` data structure are given in the section entitled “System V Messages” in Chapter 3.

A `semget(2)` system call performs one of two tasks:

- creates a new semaphore set identifier and creates an associated data structure and semaphore set for it
- locates an existing semaphore set identifier that already has an associated data structure and semaphore set

The task performed is determined by the value of the `key` argument passed to the `semget` system call. If `key` is not already in use for an existing `semid` and the `IPC_CREAT` flag is set, a new `semid` is returned with an associated data structure and semaphore set created for it, provided no system tunable parameter would be exceeded.

There is also a provision for specifying a `key` of value zero (0), which is known as the private key (`IPC_PRIVATE`). When this key is specified, a new identifier is always returned with an associated data structure and semaphore set created for it, unless a system-tunable parameter would be exceeded. The `ipcs(8)` command will show the `key` field for the `semid` as all zeros.

When a semaphore set is created, the process which calls `semget` becomes the owner/creator and the associated data structure is initialized accordingly. Remember, ownership can be changed, but the creating process always remains the creator (see the “The `semctl` System Call” section). The creator of the semaphore set also determines the initial operation permissions for the facility.

If a semaphore set identifier exists for the key specified, the value of the existing identifier is returned. If you do not want to have an existing semaphore set identifier returned, a control command (IPC_EXCL) can be specified (set) in the *semflg* argument passed to the system call. The system call will fail if it is passed a value for the number of semaphores (*nsems*) that is greater than the number actually in the set; if you do not know how many semaphores are in the set, use 0 for *nsems* (see “The semget System Call” for more information).

Once a uniquely identified semaphore set and data structure are created or an existing one is found, **semop(2)** and **semctl(2)** can be used.

Semaphore operations consist of incrementing, decrementing, and testing for zero. The **semop** system call is used to perform these operations (see “The semop System Call” for details of the **semop** system call).

The **semctl** system call permits you to control the semaphore facility in the following ways:

- by returning the value of a semaphore (GETVAL)
- by setting the value of a semaphore (SETVAL)
- by returning the PID of the last process performing an operation on a semaphore set (GETPID)
- by returning the number of processes waiting for a semaphore value to become greater than its current value (GETNCNT)
- by returning the number of processes waiting for a semaphore value to equal zero (GETZCNT)
- by getting all semaphore values in a set and placing them in an array in user memory (GETALL)
- by setting all semaphore values in a semaphore set from an array of values in user memory (SETALL)
- by retrieving the data structure associated with a semaphore set (IPC_STAT)
- by changing operation permissions for a semaphore set (IPC_SET)
- by removing a particular semaphore set identifier from the operating system along with its associated data structure and semaphore set (IPC_RMID)

See the section “The semctl System Call” for details of the **semctl** system call.

The semget System Call

semget(2) creates a new semaphore set or identifies an existing one.

This section describes how to use the **semget** system call. For more detailed information, see the **semget(2)** man page. A program illustrating use of this call can be found at `/usr/share/doc/ccur/examples/semget.c` with extensive comments provided in `README.semget.txt`.

Synopsis

```
#include <sys/types.h>
#include <sys/ipc.h>
#include <sys/sem.h>

int semget (key_t key, int nsems, int semflg);
```

All of the `#include` files are located in the `/usr/include` subdirectories of the operating system.

`key_t` is defined by a `typedef` in the `<bits/sys/types.h>` header file to be an integral type (this header file is included internally by `<sys/types.h>`). The integer returned from this system call upon successful completion is the semaphore set identifier (*semid*). The *semid* is discussed in the section “Using System V Semaphores” earlier in this chapter.

A new *semid* with an associated semaphore set and data structure is created if one of the following conditions is true:

- *key* is equal to `IPC_PRIVATE`
- *key* does not already have a *semid* associated with it and (*semflg* and `IPC_CREAT`) is “true” (not zero).

The value of *semflg* is a combination of:

- control commands (flags)
- operation permissions

Control commands are predefined constants. The following control commands apply to the `semget` system call and are defined in the `<bits/ipc.h>` header file, which is internally included by the `<sys/ipc.h>` header file:

`IPC_CREAT` used to create a new semaphore set. If not used, `semget` will find the semaphore set associated with *key* and verify access permissions.

`IPC_EXCL` used with `IPC_CREAT` to cause the system call to return an error if a semaphore set identifier already exists for the specified *key*. This is necessary to prevent the process from thinking it has received a new (unique) identifier when it has not.

Operation permissions define the read/alter attributes for users, groups and others. Table 5-1 shows the numeric values (expressed in octal notation) for the valid operation permissions codes.

Table 5-1 Semaphore Operation Permissions Codes

Operation Permissions	Octal Value
Read by User	00400
Alter by User	00200
Read by Group	00040
Alter by Group	00020
Read by Others	00004
Alter by Others	00002

A specific value is derived by adding or bitwise ORing the octal values for the operation permissions desired. That is, if “read by user” and “read/alter by others” is desired, the code value would be 00406 (00400 plus 00006).

The *semflg* value can easily be set by using the flag names in conjunction with the octal operation permissions value; for example:

```
semid = semget (key, nsems, (IPC_CREAT | 0400));
semid = semget (key, nsems, (IPC_CREAT | IPC_EXCL | 0400));
```

The following values are defined in **<linux/sem.h>**. Exceeding these values always causes a failure.

SEMMNI	determines the maximum number of unique semaphore sets (<i>semids</i>) that can be in use at any given time
SEMMSL	determines the maximum number of semaphores in each semaphore set
SEMMNS	determines the maximum number of semaphores in all semaphore sets system wide

A list of semaphore limit values may be obtained with the **ipcs(8)** command by using the following options. See the man page for further details.

```
ipcs -s -l
```

Refer to the **semget(2)** man page for specific associated data structure initialization as well as the specific error conditions.

The semctl System Call

semctl(2) is used to perform control operations on semaphore sets.

This section describes the **semctl** system call. For more detailed information, see the **semctl(2)** man page. A program illustrating use of this call can be found at `/usr/share/doc/ccur/examples/semctl.c` with extensive comments provided in `README.semctl.txt`.

Synopsis

```
#include <sys/types.h>
#include <sys/ipc.h>
#include <sys/sem.h>

int semctl (int semid, int semnum, int cmd, int arg);

union semun
{
    int val;
    struct semid_ds *buf;
    ushort *array;
} arg;
```

All of the `#include` files are located in the `/usr/include` subdirectories of the operating system.

The *semid* argument must be a valid, non-negative, integer value that has already been created using the **semget** system call.

The *semnum* argument is used to select a semaphore by its number. This relates to sequences of operations (atomically performed) on the set. When a set of semaphores is created, the first semaphore is number 0, and the last semaphore is numbered one less than the total in the set.

The *cmd* argument can be any one of the following values:

GETVAL	returns the value of a single semaphore within a semaphore set
SETVAL	sets the value of a single semaphore within a semaphore set
GETPID	returns the PID of the process that performed the last operation on the semaphore within a semaphore set
GETNCNT	returns the number of processes waiting for the value of a particular semaphore to become greater than its current value
GETZCNT	returns the number of processes waiting for the value of a particular semaphore to be equal to zero
GETALL	returns the value for all semaphores in a semaphore set
SETALL	sets all semaphore values in a semaphore set

IPC_STAT	returns the status information contained in the associated data structure for the specified <i>semid</i> , and places it in the data structure pointed to by <i>arg.buf</i>
IPC_SET	sets the effective user/group identification and operation permissions for the specified semaphore set (<i>semid</i>)
IPC_RMID	removes the specified semaphore set (<i>semid</i>) along with its associated data structure

NOTE

The **semctl(2)** service also supports the IPC_INFO, SEM_STAT and SEM_INFO commands. However, since these commands are only intended for use by the **ipcs(8)** utility, these commands are not discussed.

To perform an IPC_SET or IPC_RMID control command, a process must meet one or more of the following conditions:

- have an effective user id of OWNER
- have an effective user id of CREATOR
- be the super-user
- have the CAP_SYS_ADMIN capability

Note that a semaphore set can also be removed by using the **ipcrm(1)** command and specifying the **-s semid** or the **-S semkey** option, where *semid* specifies the identifier for the semaphore set and *semkey* specifies the key associated with the semaphore set. To use this command, a process must have the same capabilities as those required for performing an IPC_RMID control command. See the **ipcrm(1)** man page for additional information on the use of this command.

The remaining control commands require either read or write permission, as appropriate.

The *arg* argument is used to pass the system call the appropriate union member for the control command to be performed. For some of the control commands, the *arg* argument is not required and is simply ignored.

- *arg.val* required: SETVAL
- *arg.buf* required: IPC_STAT, IPC_SET
- *arg.array* required: GETALL, SETALL
- *arg* ignored: GETVAL, GETPID, GETNCNT, GETZCNT, IPC_RMID

The semop System Call

semop(2) is used to perform operations on selected members of the semaphore set.

This section describes the **semop** system call. For more detailed information, see the **semop(2)** man page. A program illustrating use of this call can be found at `/usr/share/doc/ccur/examples/semop.c` with extensive comments provided in `README.semop.txt`.

Synopsis

```
#include <sys/types.h>
#include <sys/ipc.h>
#include <sys/sem.h>

int semop (int semid, struct sembuf *sops, unsigned nsops);
```

All of the `#include` files are located in the `/usr/include` subdirectories of the operating system.

The **semop** system call returns an integer value, which is zero for successful completion or -1 otherwise.

The *semid* argument must be a valid, non-negative, integer value. In other words, it must have already been returned from a prior **semget(2)** system call.

The *sops* argument points to an array of structures in the user memory area that contains the following for each semaphore to be changed:

- the semaphore number (*sem_num*)
- the operation to be performed (*sem_op*)
- the control flags (*sem_flg*)

The **sops* declaration means that either an array name (which is the address of the first element of the array) or a pointer to the array can be used. `sembuf` is the tag name of the data structure used as the template for the structure members in the array; it is located in the `<sys/sem.h>` header file.

The *nsops* argument specifies the length of the array (the number of structures in the array). The maximum size of this array is determined by the SEMOPM system-tunable parameter. Therefore, a maximum of SEMOPM operations can be performed for each **semop** system call.

The semaphore number (*sem_num*) determines the particular semaphore within the set on which the operation is to be performed.

The operation to be performed is determined by the following:

- If *sem_op* is positive, the semaphore value is incremented by the value of *sem_op*.
- If *sem_op* is negative, the semaphore value is decremented by the absolute value of *sem_op*.
- If *sem_op* is zero, the semaphore value is tested for equality to zero.

The following operation commands (flags) can be used:

IPC_NOWAIT	can be set for any operations in the array. The system call returns unsuccessfully without changing any semaphore values at all if any operation for which IPC_NOWAIT is set cannot be performed successfully. The system call is unsuccessful when trying to decrement a semaphore more than its current value, or when testing for a semaphore to be equal to zero when it is not.
SEM_UNDO	tells the system to undo the process' semaphore changes automatically when the process exits; it allows processes to avoid deadlock problems. To implement this feature, the system maintains a table with an entry for every process in the system. Each entry points to a set of undo structures, one for each semaphore used by the process. The system records the net change.

Condition Synchronization

The following sections describe the `postwait(2)` and `server_block/server_wake(2)` system calls that can be used to manipulate cooperating processes.

The postwait System Call

The `postwait(2)` function is a fast, efficient, sleep/wakeup/timer mechanism used between a cooperating group of threads. The threads need not be members of the same process.

Synopsis

```
#include <sys/time.h>
#include <sys/rescntl.h>
#include <sys/pw.h>

int pw_getukid(ukid_t *ukid);
int pw_wait(struct timespec *t, struct resched_var *r);
int pw_post(ukid_t ukid, struct resched_var *r);
int pw_postv(int count, ukid_t targets[], int errors[], struct
resched_var *r );
int pw_getvmax(void);

gcc [options] file -lccur_rt ...
```

To go to sleep, a thread calls `pw_wait()`. The thread will wake up when:

- the timer expires
- the thread is posted to by another thread by calling `pw_post()` or `pw_postv()` with the `ukid(s)` of the `pw_waiting` thread(s)
- the call is interrupted

Threads using **postwait(2)** services are identified by their *ukid*. A thread should call **pw_getukid()** to obtain its *ukid*. The *ukid* maps to the caller's unique, global thread id. This value can be shared with the other cooperating threads that may wish to post to this thread.

For each thread, **postwait(2)** remembers at most one unconsumed post. Posting to a thread that has an unconsumed post has no effect.

For all **postwait(2)** services that have a rescheduling variable argument pointer, if that pointer is non-NULL, the lock-count of the associated rescheduling variable is decremented.

pw_wait() is used to consume a post. It is called with an optional timeout value and an optional rescheduling variable. It returns a value of 1 if it consumes a post or 0 if timed-out waiting for a post to consume.

If the time specified for the timeout value is greater than 0, the thread sleeps at most for that amount of time waiting for a post to consume. 0 is returned if this period expires without encountering a post. If the call is interrupted, EINTR is returned and the timeout value is updated to reflect the amount of time remaining. If posted to during this interval, or a previous unconsumed post is encountered, the post is consumed and 1 is returned.

If the timeout value is 0, **pw_wait()** will return immediately. It returns a 1 if it consumes a previously unconsumed post or it returns EAGAIN if there was no post available to consume.

If the pointer to the timeout value is NULL, the behavior is the same except that the thread will never timeout. If interrupted, EINTR is returned but the timeout value, which by definition is not specified, is not updated.

pw_post() sends a post to the thread identified by *ukid*. If that thread is waiting for a post, the thread wakes up and consumes the post. If that thread was not waiting for a post, the unconsumed post is remembered so that the next time that thread tries to wait for a post, it will consume the saved post and return without warning. At most, one unconsumed post can be remembered per thread.

pw_postv() can be used to post to multiple threads at once. These postings will be atomic in the sense that none will be allowed to preempt the thread doing the posting until all the postings are complete.

The *ukids* of the target threads must be put into the *targets* array. Errors for respective targets are returned in the *errors* array. The number of entries used in the *targets* and *errors* arrays must be passed in through the *count* argument.

pw_postv() returns a 0 if all succeed, or the error value of the last target to cause an error if there are any errors.

pw_getvmax() returns the maximum number of targets that can be posted to with one **pw_postv()** call. This value is determined by the PW_VMAX kernel tunable.

Refer to the **postwait(2)** man page for a listing of the types of errors that may occur.

The Server System Calls

This set of system calls enables you to manipulate processes acting as servers using an interface compatible with the PowerMAX operating system. These system calls are briefly described as follows:

server_block	blocks the calling process only if no wake-up request has occurred since the last return from server_block . If a wake-up has occurred, server_block returns immediately.
server_wake1	wakes server if it is blocked in the server_block system call; if the specified server is not blocked in this call, the wake-up request is applied to the server's next call to server_block .
server_wakevec	serves the same purpose as server_wake1 , except that a vector of processes may be specified rather than one process.

CAUTION

These system calls should be used only by single-threaded processes. The global process ID of a multiplexed thread changes according to the process on which the thread is currently scheduled. Therefore, it is possible that the wrong thread will be awakened or blocked when these interfaces are used by multiplexed threads.

server_block

server_block blocks the calling process only if no wake-up request has occurred since the last return from **server_block**.

Synopsis

```
#include <sys/types.h>
#include <sys/time.h>
#include <sys/pw.h>

int server_block(options, r, timeout)
int options;
struct resched_var *r;
struct timeval *timeout;

gcc [options] file -lccur_rt ...
```

Arguments are defined as follows:

<i>options</i>	the value of this argument must be zero
<i>r</i>	a pointer to the calling process' rescheduling variable. This argument is optional: its value can be NULL.
<i>timeout</i>	a pointer to a <code>timeval</code> structure that contains the maximum length of time the calling process will be blocked. This argument is optional: its value can be NULL. If its value is NULL, there is no time out.

The **server_block** system call returns immediately if the calling process has a pending wake-up request; otherwise, it returns when the calling process receives the next wake-up request. A return of 0 indicates that the call has been successful. A return of -1 indicates that an error has occurred; `errno` is set to indicate the error. Note that upon return, the calling process should retest the condition that caused it to block; there is no guarantee that the condition has changed because the process could have been prematurely awakened by a signal.

server_wake1

Server_wake1 is invoked to wake a server that is blocked in the **server_block** call.

Synopsis

```
#include <sys/types.h>
#include <sys/time.h>
#include <sys/pw.h>

int server_wake1(server, r)
global_lwpid_t server;
struct resched_var *r;
```

```
gcc [options] file -lccur_rt ...
```

Arguments are defined as follows:

<i>server</i>	the global process ID of the server process to be awakened
<i>r</i>	a pointer to the calling process' rescheduling variable. This argument is optional; its value can be NULL.

It is important to note that to use the **server_wake1** call, the real or effective user ID of the calling process must match the real or saved [from **exec**] user ID of the process specified by *server*.

Server_wake1 wakes the specified server if it is blocked in the **server_block** call. If the server is not blocked in this call, the wake-up request is held for the server's next call to **server_block**. **Server_wake1** also decrements the number of rescheduling locks associated with the rescheduling variable specified by *r*.

A return of 0 indicates that the call has been successful. A return of -1 indicates that an error has occurred; `errno` is set to indicate the error.

server_wakevec

The **server_wakevec** system call is invoked to wake a group of servers blocked in the **server_block** call.

Synopsis

```
#include <sys/types.h>
#include <sys/time.h>
#include <sys/pw.h>

int server_wakevec(servers, nservers, r)
global_lwpid_t *servers;
int nservers;
struct resched_var *r;

gcc [options] file -lccur_rt ...
```

Arguments are defined as follows:

<i>servers</i>	a pointer to an array of the global process IDs of the server processes to be awakened
<i>nservers</i>	an integer value specifying the number of elements in the array
<i>r</i>	a pointer to the calling process' rescheduling variable. This argument is optional; its value can be NULL.

It is important to note that to use the **server_wakevec** call, the real or effective user ID of the calling process must match the real or saved [from **exec**] user IDs of the processes specified by *servers*.

Server_wakevec wakes the specified servers if they are blocked in the **server_block** call. If a server is not blocked in this call, the wake-up request is applied to the server's next call to **server_block**. **Server_wakevec** also decrements the number of rescheduling locks associated with a rescheduling variable specified by *r*.

A return of 0 indicates that the call has been successful. A return of -1 indicates that an error has occurred; **errno** is set to indicate the error.

For additional information on the use of these calls, refer to the **server_block(2)** man page.

Applying Condition Synchronization Tools

The rescheduling variable, spin lock, and server system calls can be used to design functions that enable a producer and a consumer process to exchange data through use of a mailbox in a shared memory region. When the consumer finds the mailbox empty, it blocks until new data arrives. After the producer deposits new data in the mailbox, it wakes the waiting consumer. An analogous situation occurs when the producer generates data faster than the consumer can process it. When the producer finds the mailbox full, it blocks until the data is removed. After the consumer removes the data, it wakes the waiting producer.

A mailbox can be represented as follows:

```
struct mailbox {
    struct spin_mutex mx; /* serializes access to mailbox */
    queue_of consumers: /* waiting consumers */
    queue_of data;      /* the data, type varies */
};
```

The `mx` field is used to serialize access to the mailbox. The `data` field represents the information that is being passed from the producer to the consumer. The `full` field is used to indicate whether the mailbox is full or empty. The `producer` field identifies the process that is waiting for the mailbox to be empty. The `consumer` field identifies the process that is waiting for the arrival of data.

Using the `spin_acquire` and the `spin_release` functions, a function to enable the consumer to extract data from the mailbox can be defined as follows:

```
void
consume (box, data)
    struct mailbox *box;
    any_t *data;
{
    spin_acquire (&box->mx, &rv);
    while (box->data == empty) {
        enqueue (box->consumers, rv.rv_glpid);
        spin_unlock (&box->mx);
        server_block (0, &rv, 0);
        spin_acquire (&box->mx, &rv);
    }
    *data = dequeue (box->data);
    spin_release (&box->mx, &rv);
}
```

Note that in this function, the consumer process locks the mailbox prior to checking for and removing data. If it finds the mailbox empty, it unlocks the mailbox to permit the producer to deposit data, and it calls `server_block` to wait for the arrival of data. When the consumer is awakened, it must again lock the mailbox and check for data; there is no guarantee that the mailbox will contain data—the consumer may have been awakened prematurely by a signal.

A similar function that will enable the producer to place data in the mailbox can be defined as follows:

```
void
produce (box, data)
    struct mailbox *box;
    any_t data;
{
    spin_acquire (&box->mx, &rv);
    enqueue (box->data, data);
    if (box->consumer == empty)
        spin_release (&box->mx, &rv);
    else {
        global_lwpid_t id = dequeue (box->consumers);
        spin_unlock (&box->mx);
        server_wake1 (id, &rv);
    }
}
```

In this function, the producer process waits for the mailbox to empty before depositing new data. The producer signals the arrival of data only when the consumer is waiting; note that it does so after unlocking the mailbox. The producer must unlock the mailbox first so that the awakened consumer can lock it to check for and remove data. Unlocking the mailbox prior to the call to **server_wake1** also ensures that the mutex is held for a short time. To prevent unnecessary context switching, rescheduling is disabled until the consumer is awakened.

Programmable Clocks and Timers

This chapter provides an overview of some of the facilities that can be used for timing. The POSIX clocks and timers interfaces are based on IEEE Standard 1003.1b-1993. The clock interfaces provide a high-resolution clock, which can be used for such purposes as time stamping or measuring the length of code segments. The timer interfaces provide a means of receiving a signal or process wakeup asynchronously at some future time. In addition, high-resolution system calls are provided which can be used to put a process to sleep for a very short time quantum and specify which clock should be used for measuring the duration of the sleep. Additional clocks and timers are provided by the RCIM PCI card.

Understanding Clocks and Timers

Real-time applications must be able to operate on data within strict timing constraints in order to schedule application or system events. High resolution clocks and timers allow applications to use relative or absolute time based on a high resolution clock and to schedule events on a one-shot or periodic basis. Applications can create multiple timers for each process.

Several timing facilities are available on the iHawk system. These include POSIX clocks and timers as well as non-interrupting clocks and real-time clock timers provided by the Real-Time Clock and Interrupt Module (RCIM) PCI card. These clocks and timers and their interfaces are explained in the sections that follow.

See Chapter 7 for information about system clocks and timers.

RCIM Clocks and Timers

The Real-Time Clock and Interrupt Module (RCIM) provides two non-interrupting clocks. These clocks can be synchronized with other RCIMs when the RCIMs are chained together. The RCIM clocks are:

tick clock a 64-bit non-interrupting clock that increments by one on each tick of the common 400ns clock signal. This clock can be reset to zero and synchronized across the RCIM chain providing a common time stamp.

The tick clock can be read on any system, master or slave, using direct reads when the device file `/dev/rcim/sclk` is mapped into the address space of a program.

POSIX clock a 64-bit non-interrupting counter encoded in POSIX 1003.1 format. The upper 32 bits contain seconds and the lower 32 bits contain nanoseconds. This clock is incremented by 400 on each tick of the

common 400ns clock signal. Primarily used as a high-resolution local clock.

The RCIM POSIX clock is accessed in a manner similar to the tick clock in that the same utilities and device files are used. The POSIX clock can be loaded with any desired time; however, the value loaded is not synchronized with other clocks in an RCIM chain. Only the POSIX clock of the RCIM attached to the host is updated.

The RCIM also provides up to eight real-time clock (RTC) timers. Each of these counters is accessible using a special device file and each can be used for almost any timing or frequency control function. They are programmable to several different resolutions which, when combined with a clock count value, provide a variety of timing intervals. This makes them ideal for running processes at a given frequency (e.g., 100Hz) or for timing code segments. In addition to being able to generate an interrupt on the host system, the output of an RTC can be distributed to other RCIM boards for delivery to their corresponding host systems, or delivered to external equipment attached to one of the RCIM's external output interrupt lines. The RTC timers are controlled by `open(2)`, `close(2)` and `ioctl(2)` system calls.

For complete information about the RCIM clocks and timers, refer to the *Real-Time Clock and Interrupt Module (RCIM) User's Guide*.

POSIX Clocks and Timers

The POSIX clocks provide a high-resolution mechanism for measuring and indicating time.

There are two types of timers: one-shot and periodic. They are defined in terms of an initial expiration time and a repetition interval. The initial expiration time indicates when the timer will first expire. It may be absolute (for example, at 8:30 a.m.) or relative to the current time (for example, in 30 seconds). The repetition interval indicates the amount of time that will elapse between one expiration of the timer and the next. The clock to be used for timing is specified when the timer is created.

A one-shot timer is armed with either an absolute or a relative initial expiration time and a repetition interval of zero. It expires only once--at the initial expiration time--and then is disarmed.

A periodic timer is armed with either an absolute or a relative initial expiration time and a repetition interval that is greater than zero. The repetition interval is always relative to the time at the point of the last timer expiration. When the initial expiration time occurs, the timer is reloaded with the value of the repetition interval and continues counting. The timer may be disarmed by setting its initial expiration time to zero.

The local timer is used as the interrupt source for scheduling POSIX timer expiries. See Chapter 7 for information about the local timer.

NOTE

Access to high resolution clocks and timers is provided by system calls in both `libccur_rt` and `librt`; however, the `libcurr_rt` routines are being deprecated. It is suggested that you use the routines in `librt` by always linking with ‘rt’ before ‘ccur_rt’; for example:

```
gcc [options] file -lrt -lccur_rt ...
```

Understanding the POSIX Time Structures

The POSIX routines related to clocks and timers use two structures for time specifications: the `timespec` structure and the `itimerspec` structure. These structures are defined in the file `<time.h>`.

The `timespec` structure specifies a single time value in seconds and nanoseconds. You supply a pointer to a `timespec` structure when you invoke routines to set the time of a clock or obtain the time or resolution of a clock (for information on these routines, see “Using the POSIX Clock Routines”). The structure is defined as follows:

```
struct timespec {
    time_t  tv_sec;
    long    tv_nsec;
};
```

The fields in the structure are described as follows:

<code>tv_sec</code>	specifies the number of seconds in the time value
<code>tv_nsec</code>	specifies the number of additional nanoseconds in the time value. The value of this field must be in the range zero to 999,999,999.

The `itimerspec` structure specifies the initial expiration time and the repetition interval for a timer. You supply a pointer to an `itimerspec` structure when you invoke routines to set the time at which a timer expires or obtain information about a timer’s expiration time (for information on these routines, see “Using the POSIX Timer Routines”). The structure is defined as follows:

```
struct itimerspec {
    struct timespec it_interval;
    struct timespec it_value;
};
```

The fields in the structure are described as follows.

<code>it_interval</code>	specifies the repetition interval of a timer
<code>it_value</code>	specifies the timer’s initial expiration

Using the POSIX Clock Routines

The POSIX routines that allow you to perform a variety of functions related to clocks are briefly described as follows:

clock_settime	sets the time of a specified clock
clock_gettime	obtains the time from a specified clock
clock_getres	obtains the resolution in nanoseconds of a specified clock

Procedures for using each of these routines are explained in the sections that follow.

Using the `clock_settime` Routine

The `clock_settime(2)` system call allows you to set the time of the system time-of-day clock, `CLOCK_REALTIME`. The calling process must have root or the `CAP_SYS_NICE` capability. By definition, the `CLOCK_MONOTONIC` clocks cannot be set.

It should be noted that if you set `CLOCK_REALTIME` after system start-up, the following times may not be accurate:

- file system creation and modification times
- times in accounting and auditing records
- the expiration times for kernel timer queue entries

Setting the system clock does not affect queued POSIX timers.

Synopsis

```
#include <time.h>

int clock_settime(clockid_t which_clock,
const struct timespec *setting);
```

The arguments are defined as follows:

<i>which_clock</i>	the identifier for the clock for which the time will be set. Only <code>CLOCK_REALTIME</code> can be set.
<i>setting</i>	a pointer to a structure that specifies the time to which <i>which_clock</i> is to be set. When <i>which_clock</i> is <code>CLOCK_REALTIME</code> , the time-of-day clock is set to a new value. Time values that are not integer multiples of the clock resolution are truncated down.

A return value of 0 indicates that the specified clock has been successfully set. A return value of -1 indicates that an error has occurred; `errno` is set to indicate the error. Refer to the `clock_settime(2)` man page for a listing of the types of errors that may occur.

Using the `clock_gettime` Routine

The `clock_gettime(2)` system call allows you to obtain the time from a specified clock. This call always returns the best available resolution for the clock, usually better than one microsecond.

Synopsis

```
#include <time.h>

int clock_gettime(clockid_t which_clock, struct timespec
                 *setting) ;
```

The arguments are defined as follows:

<i>which_clock</i>	the identifier for the clock from which to obtain the time. The value of <i>which_clock</i> may be <code>CLOCK_REALTIME</code> or <code>CLOCK_MONOTONIC</code> .
<i>setting</i>	a pointer to a structure where the time of <i>which_clock</i> is returned.

A return value of 0 indicates that the call to `clock_gettime` has been successful. A return value of -1 indicates that an error has occurred; `errno` is set to indicate the error. Refer to the `clock_gettime(2)` man page for a listing of the types of errors that may occur.

Using the `clock_getres` Routine

The `clock_getres(2)` system call allows you to obtain the resolution in nanoseconds of a specified clock. This resolution determines the rounding accuracy of timing expiries set with `clock_settime(2)` and the precision used by `clock_nanosleep(2)` and `nanosleep(2)` calls using the same clock.

The clock resolutions are system dependent and cannot be set by the user.

Synopsis

```
#include <time.h>

int clock_getres(clockid_t which_clock, struct timespec
                 *resolution) ;
```

The arguments are defined as follows:

<i>which_clock</i>	the identifier for the clock for which you wish to obtain the resolution. <i>which_clock</i> may be <code>CLOCK_REALTIME</code> or <code>CLOCK_MONOTONIC</code> .
<i>resolution</i>	a pointer to a structure where the resolution of <i>which_clock</i> is returned

A return value of 0 indicates that the call to `clock_getres` has been successful. A return value of -1 indicates that an error has occurred; `errno` is set to indicate the error. Refer to the `clock_getres(2)` man page for a listing of the types of errors that may occur.

Using the POSIX Timer Routines

Processes can create, remove, set, and query timers and may receive notification when a timer expires.

The POSIX system calls that allow you to perform a variety of functions related to timers are briefly described as follows:

<code>timer_create</code>	creates a timer using a specified clock
<code>timer_delete</code>	removes a specified timer
<code>timer_settime</code>	arms or disarms a specified timer by setting the expiration time
<code>timer_gettime</code>	obtains the repetition interval for a specified timer and the time remaining until the timer expires
<code>timer_getoverrun</code>	obtains the overrun count for a specified periodic timer
<code>nanosleep</code>	pauses execution for a specified time
<code>clock_nanosleep</code>	provides a higher resolution pause based on a specified clock

Procedures for using each of these system calls are explained in the sections that follow.

Using the `timer_create` Routine

The `timer_create(2)` system call allows the calling process to create a timer using a specified clock as the timing source.

A timer is disarmed when it is created. It is armed when the process invokes the `timer_settime(2)` system call (see “Using the `timer_settime` Routine” for an explanation of this system call).

It is important to note the following:

- When a process invokes the `fork` system call, the timers that it has created are not inherited by the child process.
- When a process invokes the `exec` system call, the timers that it has created are disarmed and deleted.

Linux threads in the same thread group can share timers. The thread which calls **timer_create** will receive all of the signals, but other threads in the same threads group can manipulate the timer through calls to **timer_settime(2)**.

Synopsis

```
#include <time.h>
#include <signal.h>

int timer_create(clockid_t which_clock, struct sigevent
*timer_event_spec, timer_t created_timer_id) ;
```

The arguments are defined as follows:

which_clock the identifier for the clock to be used for the timer. The value of *which_clock* must be **CLOCK_REALTIME**.

timer_event_spec the null pointer constant or a pointer to a structure that specifies the way in which the calling process is to be asynchronously notified of the expiration of the timer:

NULL SIGALRM is sent to the process when the timer expires.

sigev_notify=SIGEV_SIGNAL
a signal specified by *sigev_signo* is sent to the process when the timer expires.

sigev_notify=SIGEV_THREAD
the specified *sigev_notify* function is called in a new thread with *sigev_value* as the argument when the timer expires. Currently not supported in **-lccur_rt**; to use, link first to **-lrt**.

sigev_notify=SIGEV_THREAD_ID
the *sigev_notify_thread_id* number should contain the **pthread_t** id of the thread that is to receive the signal *sigev_signo* when the timer expires.

sigev_notify=SIGEV_NONE
no notification is delivered when the timer expires

NOTE

The signal denoting expiration of the timer may cause the process to terminate unless it has specified a signal-handling system call. To determine the default action for a particular signal, refer to the **signal(2)** man page.

created_timer_id a pointer to the location where the timer ID is stored. This identifier is required by the other POSIX timer system calls and is unique within the calling process until the timer is deleted by the **timer_delete(2)** system call.

A return value of 0 indicates that the call to **timer_create** has been successful. A return value of -1 indicates that an error has occurred; **errno** is set to indicate the error. Refer to the **timer_create(2)** man page for a listing of the types of errors that may occur.

Using the `timer_delete` Routine

The `timer_delete(2)` system call allows the calling process to remove a specified timer. If the selected timer is already started, it will be disabled and no signals or actions assigned to the timer will be delivered or executed. A pending signal from an expired timer, however, will not be removed.

Synopsis

```
#include <time.h>
int timer_delete(timer_t timer_id);
```

The argument is defined as follows:

timer_id the identifier for the timer to be removed. This identifier comes from a previous call to `timer_create(2)` (see “Using the `timer_create` Routine” for an explanation of this system call).

A return value of 0 indicates that the specified timer has been successfully removed. A return value of -1 indicates that an error has occurred; `errno` is set to indicate the error. Refer to the `timer_delete(2)` man page for a listing of the types of errors that may occur.

Using the `timer_settime` Routine

The `timer_settime(2)` system call allows the calling process to arm a specified timer by setting the time at which it will expire. The time to expire is defined as absolute or relative. A calling process can use this system call on an armed timer to (1) disarm the timer or (2) reset the time until the next expiration of the timer.

Synopsis

```
#include <time.h>
int timer_settime(timer_t timer_id, int flags, const struct
itimerspec *new_setting, const struct itimerspec *old_setting);
```

The arguments are defined as follows:

timer_id the identifier for the timer to be set. This identifier comes from a previous call to `timer_create(2)` (see “Using the `timer_create` Routine” for an explanation of this system call).

flags an integer value that specifies one of the following:

<code>TIMER_ABSTIME</code>	causes the selected timer to be armed with an absolute expiration time. The timer will expire when the clock associated with the timer reaches the value specified by <i>it_value</i> . If this time has already passed, <code>timer_settime</code>
----------------------------	---

succeeds, and the timer-expiration notification is made.

0 causes the selected timer to be armed with a relative expiration time. The timer will expire when the clock associated with the timer reaches the value specified by *it_value*.

new_setting a pointer to a structure that contains the repetition interval and the initial expiration time of the timer.

If you wish to have a one-shot timer, specify a repetition interval (*it_interval*) of zero. In this case, the timer expires once, when the initial expiration time occurs, and then is disarmed.

If you wish to have a periodic timer, specify a repetition interval (*it_interval*) that is not equal to zero. In this case, when the initial expiration time occurs, the timer is reloaded with the value of the repetition interval and continues to count.

In either case, you may set the initial expiration time to a value that is absolute (for example, at 3:00 p.m.) or relative to the current time (for example, in 30 seconds). To set the initial expiration time to an absolute time, you must have set the `TIMER_ABSTIME` bit in the *flags* argument. Any signal that is already pending due to a previous timer expiration for the specified timer will still be delivered to the process.

To disarm the timer, set the initial expiration time to zero. Any signal that is already pending due to a previous timer expiration for this timer will still be delivered to the process.

old_setting the null pointer constant or a pointer to a structure to which the previous repetition interval and initial expiration time of the timer are returned. If the timer has been disarmed, the value of the initial expiration time is zero. The members of *old_setting* are subject to the resolution of the timer and are the same values that would be returned by a `timer_gettime(2)` call at that point in time.

A return value of 0 indicates that the specified timer has been successfully set. A return value of -1 indicates that an error has occurred; `errno` is set to indicate the error. Refer to the `timer_settime(2)` man page for a listing of the types of errors that may occur.

Using the `timer_gettime` Routine

The `timer_gettime(2)` system call allows the calling process to obtain the repetition interval for a specified timer and the amount of time remaining until the timer expires.

Synopsis

```
#include <time.h>

int timer_gettime(timer_t timer_id, struct itimerspec
*setting) ;
```

The arguments are defined as follows:

<i>timer_id</i>	the identifier for the timer whose repetition interval and time remaining are requested. This identifier comes from a previous call to timer_create(2) (see “Using the timer_create Routine” for an explanation of this system call).
<i>setting</i>	a pointer to a structure to which the repetition interval and the amount of time remaining on the timer are returned. The amount of time remaining is relative to the current time. If the timer is disarmed, the value is zero.

A return value of 0 indicates that the call to **timer_gettime** has been successful. A return value of -1 indicates that an error has occurred; `errno` is set to indicate the error. Refer to the **timer_gettime(2)** man page for a listing of the types of errors that may occur.

Using the timer_getoverrun Routine

The **timer_getoverrun(2)** system call allows the calling process to obtain the overrun count for a particular periodic timer. A timer may expire faster than the system can deliver signals to the application. If a signal is still pending from a previous timer expiration rather than queuing another signal, a count of missed expirations is maintained with the pending signal. This is the overrun count.

Timers may overrun because the signal was blocked by the application or because the timer was over-committed.

Assume that a signal is already queued or pending for a process with a timer using timer-expiration notification `SIGEV_SIGNAL`. If this timer expires while the signal is queued or pending, a timer overrun occurs, and no additional signal is sent.

NOTE

You must invoke this system call from the timer-expiration signal-handling. If you invoke it outside this system call, the overrun count that is returned is not valid for the timer-expiration signal last taken.

Synopsis

```
#include <time.h>

int timer_getoverrun(timer_t timer_id);
```

The argument is defined as follows:

<i>timer_id</i>	the identifier for the periodic timer for which you wish to obtain the overrun count. This identifier comes from a previous call to timer_create(2) (see “Using the timer_create Routine” for an explanation of this system call).
-----------------	---

If the call is successful, `timer_getoverrun` returns the overrun count for the specified timer. This count cannot exceed `DELAYTIMER_MAX` in the file `<limits.h>`. A return value of -1 indicates that an error has occurred; `errno` is set to indicate the error. Refer to the `timer_getoverrun(2)` man page for a listing of the types of errors that may occur.

Using the POSIX Sleep Routines

The `nanosleep(2)` and the `clock_nanosleep(2)` POSIX system calls provide a high-resolution sleep mechanism that causes execution of the calling process or thread to be suspended until (1) a specified period of time elapses or (2) a signal is received and the associated action is to execute a signal-handling system call or terminate the process.

The `clock_nanosleep(2)` system call provides a high-resolution sleep with a specified clock. It suspends execution of the currently running thread until the time specified by *rqtp* has elapsed or until the thread receives a signal.

The use of these system calls has no effect on the action or blockage of any signal.

Using the nanosleep Routine

Synopsis

```
#include <time.h>

int nanosleep(const struct timespec *req, struct timespec
*rem);
```

Arguments are defined as follows:

<i>req</i>	a pointer to a <code>timespec</code> structure that contains the length of time that the process is to sleep. The suspension time may be longer than requested because the <i>req</i> value is rounded up to an integer multiple of the sleep resolution or because of the scheduling of other activity by the system. Except for the case of being interrupted by a signal, the suspension time will not be less than the time specified by <i>req</i> , as measured by <code>CLOCK_REALTIME</code> . You will obtain a resolution of one microsecond on the blocking request.
<i>rem</i>	the null pointer constant or a pointer to a <code>timespec</code> structure to which the amount of time remaining in the sleep interval is returned if <code>nanosleep</code> is interrupted by a signal. If <i>rem</i> is <code>NULL</code> and <code>nanosleep</code> is interrupted by a signal, the time remaining is not returned.

A return value of 0 indicates that the requested period of time has elapsed. A return value of -1 indicates that an error has occurred; `errno` is set to indicate the error. Refer to the `nanosleep(2)` man page for a listing of the types of errors that may occur.

Using the `clock_nanosleep` Routine

Synopsis

```
#include <time.h>

int clock_nanosleep(clockid_t which_clock, int flags,
const struct timespec *rqtp, struct timespec *rmtp);
```

The arguments are defined as follows:

which_clock the identifier for the clock to be used. The value of *which_clock* may be `CLOCK_REALTIME` or `CLOCK_MONOTONIC`.

flags an integer value that specifies one of the following:

`TIMER_ABSTIME` interprets the time specified by *rqtp* to be absolute with respect to the clock value specified by *which_clock*.

`0` interprets the time specified by *rqtp* to be relative to the current time.

rqtp a pointer to a `timespec` structure that contains the length of time that the process is to sleep. If the `TIMER_ABSTIME` flag is specified and the time value specified by *rqtp* is less than or equal to the current time value of the specified clock (or the clock's value is changed to such a time), the function will return immediately. Further, the time slept is affected by any changes to the clock after the call to `clock_nanosleep(2)`. That is, the call will complete when the actual time is equal to or greater than the requested time no matter how the clock reaches that time, via setting or actual passage of time or some combination of these.

The time slept may be longer than requested as the specified time value is rounded up to an integer multiple of the clock resolution, or due to scheduling and other system activity. Except for the case of interruption by a signal, the suspension time is never less than requested.

rmtp If `TIMER_ABSTIME` is not specified, the `timespec` structure pointed to by *rmtp* is updated to contain the amount of time remaining in the interval (i.e., the requested time minus the time actually slept). If *rmtp* is `NULL`, the remaining time is not set. The *rmtp* value is not set in the case of an absolute time value.

On success, `clock_nanosleep` returns a value of 0 after at least the specified time has elapsed. On failure, `clock_nanosleep` returns the value -1 and `errno` is set to indicate the error. Refer to the `clock_nanosleep(2)` man page for a listing of the types of errors that may occur.

System Clocks and Timers

This chapter describes system timekeeping, the local timer and the effect of disabling the local timer on system functions.

System Timekeeping

Standard Linux system timekeeping uses a “clocksource” mechanism that includes separate architecture drivers that consist of a routine to read the value of the timer and calibration values to convert timer counts to nanoseconds.

In RedHawk, a TSC based clock is used to satisfy most timekeeping requests. Kernel tunables `REQUIRE_TSC` and `REQUIRE_RELIABLE_TSC`, accessible under **Processor Type & Features** on the Kernel Configuration GUI, are enabled in the pre-built kernels by default to ensure that aspects of power management that are known to damage the reliability of the TSC are not configured in the kernel.

In addition, the TSC is disciplined to a second clocksource to improve the stability of the clock. When an RCIM is present in the system, the RCIM is used as the second clocksource; otherwise, the HPET or PM timer is used.

Reading the file `/sys/devices/system/clocksource/clocksource0/current_clocksource` displays the current secondary clocksource. Writing the name of another clocksource to this file using `echo(1)` will change the assignment.

Boot command line options are available to check the BIOS for proper TSC synchronization and if the TSCs are not synced correctly resync them at the end of the boot (`tsc_sync=auto` [this is the default]), force resynchronization (`tsc_sync=force`), and check the BIOS and if not synced correctly disable the TSCs as a possible clocksource (`tsc_sync=check`). Note that hotplugged CPUs do not have an opportunity to be re-synced by the operating system. For them, only TSC sync checking is available.

See the txt files in the `/kernel-source/Documentation/hrtimers` to learn more about these timekeeping features.

Local Timer

On Concurrent’s iHawk systems, each CPU has a local (private) timer which is used as a source of periodic interrupts local to that CPU. By default these interrupts occur 100 times per second and are staggered in time so that only one CPU is processing a local timer interrupt at a time.

The local timer interrupt routine performs the following local timing functions, which are explained in more detail in the sections that follow:

- gathers CPU utilization statistics, used by **top(1)** and other utilities
- causes the process running on the CPU to periodically consume its time quantum
- causes the running process to release the CPU in favor of another running process when its time quantum is used up
- periodically balances the load of runnable processes across CPUs
- implements process and system profiling
- implements system time-of-day (wall) clock and execution time quota limits for those processes that have this feature enabled
- provides the interrupt source for POSIX timers
- polls for a quiescent state on each CPU to free data structures during read copy update (RCU) processing
- updates the system time-of-day (wall) clock and ticks-since-boot times
- dispatches events off the system timer list. This includes driver watchdog timers and process timer functions such as **alarm(2)**

Shielding local timers limits the use of the local timer to scheduling events which are requested by processes that have affinity to the local CPU. Local timer shielding works with process shielding by moving less important work to an unshielded CPU. This improves both the worst-case interrupt response time and the determinism of program execution on the CPU as described in the “Real-Time Performance” chapter. However, disabling the local timer has an effect on some functionality normally provided by RedHawk Linux. These effects are described below.

Functionality

The local timer performs the functions described in the sections below. The effect of disabling the local timer is discussed as well as viable alternatives for some of the features.

CPU Accounting

Per-process CPU utilization is reported by utilities such as **top(1)** and **ps(1)**. These utilities gather CPU utilization statistics from system services such as **times(2)**, **wait4(2)**, **sigaction(2)**, and **acct(2)**.

On standard non-RedHawk Linux kernels, these services are dependent on the local timer to determine process cpu utilization. However, RedHawk kernels use the high resolution process accounting facility instead of the local timer to accomplish this. High resolution process accounting continues to function even when the local timer is disabled.

High resolution process accounting is enabled in all pre-built RedHawk kernels via the HRACCT kernel tunable accessible under **General Setup** on the Kernel Configuration GUI. Refer to the **hracct(3)** and **hracct(7)** man pages for complete information about this facility.

Process Execution Time Quanta and Limits

The local timer is used to expire the quantum of processes scheduled in the `SCHED_OTHER` and `SCHED_RR` scheduling policies. This allows processes of equal scheduling priority to share the CPU in a round-robin fashion. If the local timer is disabled on a CPU, processes on that CPU will no longer have their quantum expired. This means that a process executing on this CPU will run until it either blocks, or until a higher priority process becomes ready to run. In other words, on a CPU where the local timer interrupt is disabled, a process scheduled in the `SCHED_RR` scheduling policy will behave as if it were scheduled in the `SCHED_FIFO` scheduling policy. Note that processes scheduled on CPUs where the local timer is still enabled are unaffected. For more information about process scheduling policies, see Chapter 4, “Process Scheduling”.

The `setrlimit(2)` and `getrlimit(2)` system calls allow a process to set and get a limit on the amount of CPU time that a process can consume. When this time period has expired, the process is sent the signal `SIGXCPU`. The accumulation of CPU time is done in the local timer interrupt routine. Therefore if the local timer is disabled on a CPU, the time that a process executes on the CPU will not be accounted for. If this is the only CPU where the process executes, it will never receive a `SIGXCPU` signal.

Interval Timer Decrementing

The `setitimer(2)` and `getitimer(2)` system calls allow a process to set up a “virtual timer” and obtain the value of the timer, respectively. A virtual timer is decremented only when the process is executing. There are two types of virtual timers: one that decrements only when the process is executing at user level, and one that is decremented when the process is executing at either user level or kernel level. When a virtual timer expires, a signal is sent to the process. Decrementing virtual timers is done in the local timer routine. Therefore when the local timer is disabled on a CPU, none of the time used will be decremented from the virtual timer. If this is the only CPU where the process executes, then its virtual timer will never expire.

System Profiling

The local timer drives system profiling. The sample that the profiler records is triggered by the firing of the local timer interrupt. If the local timer is disabled on a given CPU, the `gprof(1)` command and `profil(2)` system service will not function correctly for processes that run on that CPU.

CPU Load Balancing

The local timer interrupt routine will periodically call the load balancer to be sure that the number of runnable processes on this CPU is not significantly lower than the number of runnable processes on other CPUs in the system. If this is the case, the load balancer will steal processes from other CPUs to balance the load across all CPUs. On a CPU where the local timer interrupt has been disabled, the load balancer will only be called when the CPU has no processes to execute. The loss of this functionality is generally not a problem for a shielded CPU because it is generally not desirable to run background processes on a shielded CPU.

CPU Rescheduling

The `RESCHED_SET_LIMIT` function of the `resched_cntl(2)` system call allows a user to set an upper limit on the amount of time that a rescheduling variable can remain locked. The `SIGABRT` signal is sent to the process when the time limit is exceeded. This feature is provided to debug problems during application development. When a process with a locked rescheduling variable is run on a CPU on which the local timer is disabled, the time limit is not decremented and therefore the signal may not be sent when the process overruns the specified time limit.

POSIX Timers

The local timer provides the timing source for POSIX timers. If a CPU is shielded from local timer interrupts, the local timer interrupts will still occur on the shielded CPU if a process on that CPU has an active POSIX timer or `nanosleep(2)` function. If a process is not allowed to run on the shielded CPU, its timers will be migrated to a CPU where the process is allowed to run.

RCU Processing

The kernel read copy update (RCU) code traditionally relies on the local timer to poll for a quiescent state on each CPU to free data structures. When a CPU is shielded from local timer interrupts, that CPU can no longer perform the needed RCU processing. A synchronization mechanism launches RCU processing at an arbitrary point and completes without waiting for a timer driven poll, eliminating the local timer's participation in RCU processing. This synchronization occurs when the `RCU_ALTERNATIVE` kernel parameter is set in conjunction with the `SHIELD` parameter, which is the default in all pre-built kernels. When `RCU_ALTERNATIVE` is not set in the kernel, the RCU code uses the local timer.

Miscellaneous

In addition to the functionality listed above, some of the functions provided by some standard Linux commands and utilities may not function correctly on a CPU if its local timer is disabled. These include:

`bash(1)`
`sh(1)`
`strace(1)`

For more information about these commands and utilities, refer to the corresponding man pages.

Disabling the Local Timer

By shielding local timers, the local timer is disabled for any mix of CPUs. Shielding is done via the `shield(1)` command or by assigning a hexadecimal value to `/proc/shield/ltmrs`. This hexadecimal value is a bitmask of CPUs; the radix position of each bit identifies one CPU and the value of that bit specifies whether or not

that CPU's local timer is to be disabled (=1) or enabled (=0). See Chapter 2, "Real-Time Performance" and the **shield(1)** man page for more information.

This chapter describes the **xfs** journaling file system and the procedures for performing direct disk I/O on the RedHawk Linux operating system.

Journaling File System

Traditional file systems must perform special file system checks after an interruption, which can take many hours to complete depending upon how large the file system is. A journaling file system is a fault-resilient file system, ensuring data integrity by maintaining a special log file called a *journal*. When a file is updated, the file's metadata are written to the journal on disk before the original disk blocks are updated. If a system crash occurs before the journal entry is committed, the original data is still on the disk and only new changes are lost. If the crash occurs during the disk update, the journal entry shows what was supposed to have happened. On reboot, the journal entries are replayed and the update that was interrupted is completed. This drastically cuts the complexity of a file system check, reducing recovery time.

Support for the XFS journaling file system from SGI is enabled by default in RedHawk Linux. XFS is a multithreaded, 64-bit file system capable of handling files as large as a million terabytes. In addition to large files and large file systems, XFS can support extended attributes, variable block sizes, is extent based and makes extensive use of Btrees (directories, extents, free space) to aid both performance and scalability. Both user and group quotas are supported.

The journaling structures and algorithms log read and write data transactions rapidly, minimizing the performance impact of journaling. XFS is capable of delivering near-raw I/O performance.

Extended attributes are name/value pairs associated with a file. Attributes can be attached to regular files, directories, symbolic links, device nodes and all other types of inodes. Attribute values can contain up to 64KB of arbitrary binary data. Two attribute namespaces are available: a user namespace available to all users protected by the normal file permissions, and a system namespace accessible only to privileged users. The system namespace can be used for protected file system metadata such as access control lists (ACLs) and hierarchical storage manage (HSM) file migration status.

NFS Version 3 can be used to export 64-bit file systems to other systems that support that protocol. NFS V2 systems have a 32-bit limit imposed by the protocol.

Backup and restore of XFS file systems to local and remote SCSI tapes or files is done using **xfsdump** and **xfsrestore**. Dumping of extended attributes and quota information is supported.

The Data Management API (DMAPI/XDSM) allows implementation of hierarchical storage management software as well as high-performance dump programs without requiring raw access to the disk and knowledge of file system structures.

A full set of tools is provided with XFS. Extensive documentation for the XFS file system can be found at:

<http://oss.sgi.com/projects/xfs/>

Creating an XFS File System

To create an XFS file system, the following is required:

- Identify a partition on which to create the XFS file system. It may be from a new disk, unpartitioned space on an existing disk, or by overwriting an existing partition. Refer to the **fdisk(1)** man page if creating a new partition.
- Use **mkfs.xfs(8)** to create the XFS file system on the partition. If the target disk partition is currently formatted for a file system, use the **-f** (force) option.

```
mkfs.xfs [-f] /dev/devfile
```

where *devfile* is the partition where you wish to create the file system; e.g., **sdb3**. Note that this will destroy any data currently on that partition.

Mounting an XFS File System

Use the **mount(8)** command to mount an XFS file system:

```
mount -t xfs /dev/devfile /mountpoint
```

Refer to the **mount(8)** man page for options available when mounting an XFS file system.

Because XFS is a journaling file system, before it mounts the file system it will check the transaction log for any unfinished transactions and bring the file system up to date.

Data Management API (DMAPI)

DMAPI is the mechanism within the XFS file system for passing file management requests between the kernel and a hierarchical storage management system (HSM).

To build DMAPI, set the XFS_DMAPI system parameter accessible under File Systems on the Kernel Configuration GUI as part of your build.

For more information about building DMAPI, refer to

<http://oss.sgi.com/projects/xfs/dmapi.html>

Direct Disk I/O

Normally, all reads and writes to a file pass through a file system cache buffer. Some applications, such as database programs, may need to do their own caching. Direct I/O is an unbuffered form of I/O that bypasses the kernel's buffering of data. With direct I/O, the file system transfers data directly between the disk and the user-supplied buffer.

RedHawk Linux enables a user process to both read directly from--and write directly to--disk into its virtual address space, bypassing intermediate operating system buffering and increasing disk I/O speed. Direct disk I/O also reduces system overhead by eliminating copying of the transferred data.

To set up a disk file for direct I/O use the **open(2)** or **fcntl(2)** system call. Use one of the following procedures:

- Invoke the **open** system call from a program; specify the path name of a disk file; and set the `O_DIRECT` bit in the *oflag* argument.
- For an open file, invoke the **fcntl** system call; specify an open file descriptor; specify the `F_SETFL` command, and set the `O_DIRECT` bit in the *arg* argument.

Direct disk I/O transfers must meet all of the following requirements:

- The user buffer must be aligned on a byte boundary that is an integral multiple of the `_PC_REC_XFER_ALIGN` **pathconf(2)** variable.
- The current setting of the file pointer locates the offset in the file at which to start the next I/O operation. This setting must be an integral multiple of the value returned for the `_PC_REC_XFER_ALIGN` **pathconf(2)** variable.
- The number of bytes transferred in an I/O operation must be an integral multiple of the value returned for the `_PC_REC_XFER_ALIGN` **pathconf(2)** variable.

Enabling direct I/O for files on file systems not supporting direct I/O returns an error. Trying to enable direct disk I/O on a file in a file system mounted with the file system-specific **soft** option also causes an error. The **soft** option specifies that the file system need not write data from cache to the physical disk until just before unmounting.

Although not recommended, you can open a file in both direct and cached (nondirect) modes simultaneously, at the cost of degrading the performance of both modes.

Using direct I/O does not ensure that a file can be recovered after a system failure. You must set the POSIX synchronized I/O flags to do so.

You cannot open a file in direct mode if a process currently maps any part of it with the **mmap(2)** system call. Similarly, a call to **mmap** fails if the file descriptor used in the call is for a file opened in direct mode.

Whether direct I/O provides better I/O throughput for a task depends on the application:

- All direct I/O requests are synchronous, so I/O and processing by the application cannot overlap.
- Since the operating system cannot cache direct I/O, no read-ahead or write-behind algorithm improves throughput.

However, direct I/O always reduces system-wide overhead because data moves directly from user memory to the device with no other copying of the data. Savings in system overhead is especially pronounced when doing direct disk I/O between an embedded SCSI disk controller (a disk controller on the processor board) and local memory on the same processor board.

Memory Mapping

This chapter describes the methods provided by RedHawk Linux for a process to access the contents of another process' address space.

Establishing Mappings to a Target Process' Address Space

For each running process, the `/proc` file system provides a file that represents the address space of the process. The name of this file is `/proc/pid/mem`, where `pid` denotes the ID of the process whose address space is represented. A process can `open(2)` a `/proc/pid/mem` file and use the `read(2)` and `write(2)` system calls to read and modify the contents of another process' address space.

The `usermap(3)` library routine, which resides in the `libccur_rt` library, provides applications with a way to efficiently monitor and modify locations in currently executing programs through the use of simple CPU reads and writes.

The underlying kernel support for this routine is the `/proc` file system `mmap(2)` system service call, which lets a process map portions of another process' address space into its own address space. Thus, monitoring and modifying other executing programs becomes simple CPU reads and writes within the application's own address space, without incurring the overhead of `/proc` file system `read(2)` and `write(2)` calls.

The sections below describe these interfaces and lists considerations when deciding whether to use `mmap(2)` or `usermap(3)` within your application.

Using `mmap(2)`

A process can use `mmap(2)` to map a portion of its address space to a `/proc/pid/mem` file, and thus directly access the contents of another process' address space. A process that establishes a mapping to a `/proc/pid/mem` file is hereinafter referred to as a monitoring process. A process whose address space is being mapped is referred to as a target process.

To establish a mapping to a `/proc/pid/mem` file, the following requirements must be met:

- The file must be opened with at least read permission. If you intend to modify the target process' address space, then the file must also be opened with write permission.
- On the call to `mmap` to establish the mapping, the flags argument should specify the `MAP_SHARED` option, so that reads and writes to the target process' address space are shared between the target process and the monitoring process.

- The target mappings must be to real memory pages and not within a HUGETLB area. The current implementation does not support the creation of mappings to HUGETLB areas.

It is important to note that a monitoring process' resulting **mmap** mapping is to the target process' physical memory pages that are currently mapped in the range $[offset, offset + length)$. As a result, a monitoring process' mapping to a target process' address space can become invalid if the target's mapping changes after the **mmap** call is made. In such circumstances, the monitoring process retains a mapping to the underlying physical pages, but the mapping is no longer shared with the target process. Because a monitoring process cannot detect that a mapping is no longer valid, you must make provisions in your application for controlling the relationship between the monitoring process and the target. (The notation $[start, end)$ denotes the interval from *start* to *end*, including *start* but excluding *end*.)

Circumstances in which a monitoring process' mapping to a target process' address space becomes invalid are:

- The target process terminates.
- The target process unmaps a page in the range $[offset, offset + length)$ with either **munmap(2)** or **mremap(2)**.
- The target process maps a page in the range $[offset, offset + length)$ to a different object with **mmap(2)**.
- The target process invokes **fork(2)** and writes into an unlocked, private, writable page in the range $[offset, offset + length)$ before the child process does. In this case, the target process receives a private copy of the page, and its mapping and write operation are redirected to the copied page. The monitoring process retains a mapping to the original page.
- The target process invokes **fork(2)** and then locks into memory a private, writable page in the range $[offset, offset + length)$, where this page is still being shared with the child process (the page is marked copy-on-write). In this case, the process that performs the lock operation receives a private copy of the page (as though it performed the first write to the page). If it is the target (parent) process that locks the page, then the monitoring process' mapping is no longer valid.
- The target process invokes **mprotect(2)** to enable write permission on a locked, private, read-only page in the range $[offset, offset + length)$ that is still being shared with the child process (the page is marked copy-on-write). In this case, the target process receives a private copy of the page. The monitoring process retains a mapping to the original memory object.

If your application is expected to be the target of a monitoring process' address space mapping, you are advised to:

- Perform memory-locking operations in the target process before its address space is mapped by the monitoring process.
- Prior to invoking **fork(2)**, lock into memory any pages for which mappings by the parent and the monitoring process need to be retained.

If your application is not expected to be the target of address space mapping, you may wish to postpone locking pages in memory until after invoking **fork**.

Please refer to the **mmap(2)** man page for additional details.

Using `usermap(3)`

In addition to the `/proc` file system `mmap(2)` system service call support, RedHawk Linux also provides the `usermap(3)` library routine as an alternative method for mapping portions of a target process' address space into the virtual address space of the monitoring process. This routine resides in the `libccur_rt` library.

While the `usermap` library routine internally uses the underlying `/proc mmap` system service call interface to create the target address space mappings, `usermap` does provide the following additional features:

- The caller only has to specify the virtual address and length of the virtual area of interest in the target process' address space. The `usermap` routine will deal with the details of converting this request into a page aligned starting address and a length value that is a multiple of the page size before calling `mmap`.
- The `usermap` routine is intended to be used for mapping multiple target process data items, and therefore it has been written to avoid the creation of redundant `mmap` mappings. `usermap` maintains internal `mmap` information about all existing mappings, and when a requested data item mapping falls within the range of an already existing mapping, then this existing mapping is re-used, instead of creating a redundant, new mapping.
- When invoking `mmap`, you must supply an already opened file descriptor. It is your responsibility to `open(2)` and `close(2)` the target process' file descriptor at the appropriate times.

When using `usermap`, the caller only needs to specify the process ID (`pid_t`) of the target process. The `usermap` routine will deal with opening the correct `/proc/pid/mem` file. It will also keep this file descriptor open, so that additional `usermap(3)` calls for this same target process ID will not require re-opening this `/proc` file descriptor.

Note that leaving the file descriptor open may not be appropriate in all cases. However, it is possible to explicitly close the file descriptor(s) and flush the internal mapping information that `usermap` is using by calling the routine with a `len` parameter value of 0. It is recommended that the monitoring process use this close-and-flush feature only after all target mappings have been created, so that callers may still take advantage of the optimizations that are built into `usermap`. Please see the `usermap(3)` man page for more details on this feature.

Note that the same limitations discussed under "Using `mmap(2)`" about a monitoring process' mappings becoming no longer valid also apply to `usermap` mappings, since the `usermap` library routine also internally uses the same underlying `/proc/pid/mem mmap(2)` system call support.

For more information on the use of the `usermap(3)` routine, refer to the `usermap(3)` man page.

Considerations

In addition to the previously mentioned **usermap** features, it is recommended that you also consider the following remaining points when deciding whether to use the **usermap(3)** library routine or the **mmap(2)** system service call within your application:

- The **mmap(2)** system call is a standard System V interface, although the capability of using it to establish mappings to **/proc/pid/mem** files is a Concurrent RedHawk Linux extension. The **usermap(3)** routine is entirely a Concurrent RedHawk Linux extension.
- **Mmap(2)** provides direct control over the page protections and location of mappings within the monitoring process. **usermap(3)** does not.

Kernel Configuration Parameters

There are two Concurrent RedHawk Linux kernel configuration parameters that directly affect the behavior of the **/proc** file system **mmap(2)** calls. Because **usermap(3)** also uses the **/proc** file system **mmap(2)** support, **usermap(3)** is equally affected by these configuration parameters.

The kernel configuration parameters are accessible under Pseudo File Systems on the Kernel Configuration GUI:

PROCMEM_MMAP If this kernel configuration parameter is enabled, the **/proc** file system **mmap(2)** support will be built into the kernel.

If this kernel configuration parameter is disabled, no **/proc** file system **mmap(2)** support is built into the kernel. In this case, **usermap(3)** and **/proc mmap(2)** calls will return an **errno** value of **ENODEV**.

This kernel configuration parameter is enabled by default in all Concurrent RedHawk Linux kernel configuration files.

PROCMEM_ANYONE If this kernel configuration parameter is enabled, any **/proc/pid/mem** file that the monitoring process is able to successfully **open(2)** with read or read/write access may be used as the target process for a **/proc mmap(2)** or **usermap(3)** call.

If this kernel configuration parameter is disabled, the monitoring process may only **/proc mmap(2)** or **usermap(3)** a target process that is currently being ptraced by the monitoring process. Furthermore, the ptraced target process must also be in a stopped state at the time the **/proc mmap(2)** system service call is made. (See the **ptrace(2)** man page for more information on ptracing other processes.)

This kernel configuration parameter is enabled by default in all Concurrent RedHawk Linux kernel configuration files.

Non-Uniform Memory Access (NUMA)

NUMA support, available on AMD Opteron and Intel Nehalem systems, allows you to influence the memory location from which a program's pages are to be allocated.

Overview

On a system with non-uniform memory access (NUMA), it takes longer to access some regions of memory than others. A multiprocessor AMD Opteron (or Intel Nehalem) system is a NUMA architecture. This is because each CPU chip is associated with its own memory resources. The CPU and its associated memory are located on a unique physical bus. A CPU may quickly access the memory region that is on its local memory bus, but other CPUs must traverse one or more additional physical bus connections to access memory which is not local to that CPU. The relationship between CPUs and buses is shown in Figure 10-1.

Figure 10-1 CPU/Bus Relationship on a NUMA System

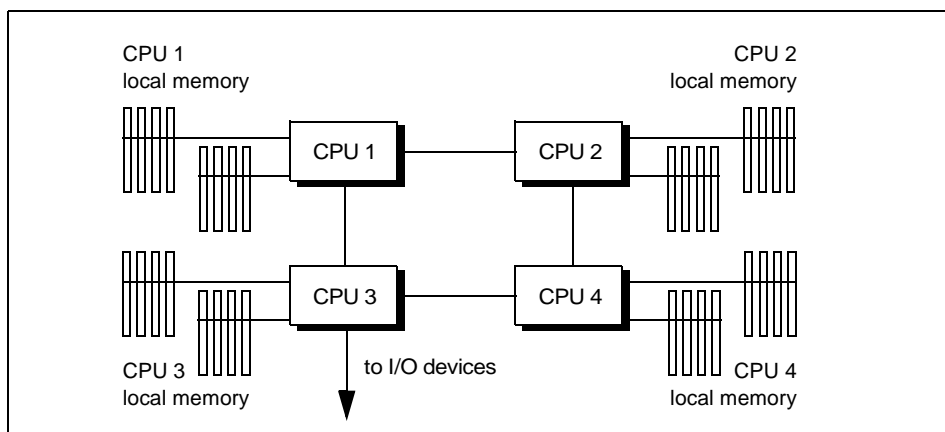

This means that the time to access memory on an AMD Opteron (or Intel Nehalem) system is going to be dependent upon the CPU where a program runs and the memory region where the program's pages are allocated.

A NUMA node is defined to be one region of memory and all CPUs that reside on the same physical bus as the memory region of the NUMA node. During system boot the kernel determines the NUMA memory-to-CPU layout, creating structures that define the association of CPUs and NUMA nodes. On current NUMA systems, the physical bus where a memory region resides is directly connected to only one CPU.

To get optimal performance, a program must run on a CPU that is local to the memory pages being utilized by that program. The NUMA interfaces described in this chapter allow a program to specify the node from which a program's pages are allocated, and to shield NUMA node(s) so that user pages are migrated to/from the shielded nodes' memory to reduce the amount of remote memory accesses for real-time applications.

When coupled with the mechanisms for setting a process' CPU affinity, these interfaces allow a program to obtain very deterministic memory access times.

NUMA support is available only on iHawk systems with AMD Opteron and Intel Nehalem processors. It is possible to configure a NUMA system so that some CPUs do not have any memory that is local. In this situation the CPUs with no memory will either be assigned to a NUMA node with no memory resources (32-bit mode) or be artificially assigned to a NUMA node with the memory (64-bit mode). In either case, all of the memory accesses from the CPU will be remote memory accesses. This affects the memory performance of processes executing on CPUs with no local memory as well as those processes executing on NUMA nodes where the remote access requests are occurring. This is not an optimal configuration for deterministic program execution.

Refer to the section "Configuration" later in this chapter for configuration details. Refer to the section "Performance Guidelines" for more information on how to optimize memory performance and to obtain deterministic memory access time. Note that deterministic memory access is crucial for obtaining deterministic program execution times.

Memory Policies

NUMA support implements the concept of memory policies. These memory policies are applied task-wide on a per-user-task basis. Ranges of virtual address space within a given task may also have their own separate memory policy, which takes precedence over the task-wide memory policy for those pages. Memory policies, both task-wide and for virtual address areas, are inherited by the child task during a fork/clone operation.

The NUMA memory policies are:

MPOL_DEFAULT This is the default where memory pages are allocated from memory local to the current CPU, provided that memory is available. This is the policy that is used whenever a task or its children have not specified a specific memory policy. You can explicitly set the **MPOL_DEFAULT** policy as the task-wide memory policy or for a virtual memory area within a task that is set to a different task-wide memory policy.

MPOL_BIND This is a strict policy that restricts memory allocation to only the nodes specified in a nodemask at the time this policy is set. Pages are allocated only from the specified node(s) and page allocations can fail even when memory is available in other nodes not in the bind nodemask. When this type of page allocation failure occurs, the process, all of its children and all threads that share the same address space will be terminated by the kernel with SIGKILL signal(s). This policy provides more certainty as to which node(s) pages are allocated from than the other memory policies.

Note that the only way to guarantee that all future memory allocations for a process will be to local memory is to set both the CPU affinity and **MPOL_BIND** policy to a single CPU or to a set of CPUs that all reside in the same NUMA node.

MPOL_PREFERRED	This policy sets a preferred (single) node for allocation. The kernel will try to allocate pages from this node first and use other nodes when the preferred node is low on free memory.
MPOL_INTERLEAVE	This policy interleaves (in a round-robin fashion) allocations to the nodes specified in the nodemask. This optimizes for bandwidth instead of latency. To be effective, the memory area should be fairly large.

In addition to user-space page allocations, many of the kernel memory allocation requests are also determined by the currently executing task's task-wide memory policy. However, not all kernel page allocations are controlled by the current task's memory policy. For example, most device drivers that allocate memory for DMA purposes will instead allocate memory from the node where the device's I/O bus resides, or the from the node that is closest to that I/O bus.

Page allocations that have already been made are not affected by changes to a task's memory policies. As an example, assume that there is a 1-to-1 CPU to node correspondence on a system with two CPUs:

If a task has been executing for a while on CPU 0 with a CPU affinity of 0x1 and a memory policy of MPOL_DEFAULT, and it then changes its CPU affinity to 0x2 and its memory policy to MPOL_BIND with a nodemask value of 0x2, there will most likely be pages in its address space that will be non-local to the task once that task begins execution on CPU 1.

The following sections describe the system services, library functions and utilities available for NUMA management.

NUMA User Interface

The **shield(1)** command can be used to control and query NUMA node memory shielding. The **run(1)** command can be used to establish or change memory policies for a task at run time, and to view user page counts of the pages in each NUMA node for specified process(es) or thread(s). **shmconfig(1)** can be used for shared memory areas.

Library functions, system services and other utilities and files are also available for NUMA control.

Details of this support are given in the sections below.

Memory-shielded Nodes

The **shield(1)** command can be used to create memory-shielded NUMA nodes.

When a NUMA node's memory is shielded, the amount of remote memory accesses are reduced because user pages that belong to applications that are *not* biased to execute on the shielded node are moved out of the shielded node's memory. In the same manner, user pages that belong to applications that *are* biased to the shielded node are moved into the shielded node's memory. This *page migration* is automatically performed when a NUMA node is initially memory-shielded, and whenever the scheduler CPU affinity for that task is modified and there are currently one or more memory-shielded NUMA nodes

configured in the system. For more details about memory shielding, see **memory_shielding(7)**.

The following option to **shield** is used to enable, disable and query memory shielding support:

--mem=MEMSHIELD, -m MEMSHIELD

MEMSHIELD may be either **0**, **1** or **q** to disable, enable or query memory shielding support, respectively.

shield used on multi-node NUMA systems with no options or with the **-c** option displays which CPUs are memory-shielded. The **cpu(1)** command also shows memory-shielded CPUs.

There are two separate attributes that cause a NUMA node to become memory-shielded:

- Memory shielding support must be enabled with the **shield -m1** command.
- All CPUs residing on the same NUMA node must be process-shielded with either **shield -p** or **shield -a**. The **run(1)** command **-Mn** option can be used to view the CPUs on each NUMA node in the system.

These two steps can be used together or in separate invocations of **shield**. Refer to the **shield(1)** man page for details.

For best performance, it is recommended that the following sequence be followed:

- First, create the shielded memory NUMA node, then
- Start up the real-time application on that node.

The following example shows the correct sequence on a four-CPU dual-core system:

```
shield -m1 -p 2,3
run -b 2,3 rt-app &
```

Because shared read-only pages, such as system library text and read-only data pages, can be mapped and accessed by many tasks, these pages are replicated (have their contents copied while keeping the same identity) in the local NUMA node's memory if the page resides in a node different than the node on which the requesting CPU or process resides. This further reduces the number of remote memory accesses in the system.

numapgs(1) and **/proc/pid/numa_maps** can be used to view a process's currently replicated pages, when present.

This support can be built into the kernel to be active always or activated manually. See "Configuration" on page 10-15 for details. For more details about how page replication is performed, see **page_replication(7)**.

Memory-shielding and Preallocated Graphics Pages

For an overview of the preallocated graphics pages support, please refer to the “Graphics Interrupts” section in Appendix G.

On NUMA systems with NVIDIA graphics cards, you may optionally set up the preallocated graphics pages on specific NUMA nodes as part of the system memory shielding configuration. Note that preallocated graphics pages are not automatically re-allocated in non-memory-shielded nodes when a node becomes memory-shielded.

Pre-allocated graphics pages are initially allocated in an interleaved fashion across all NUMA nodes that have their memory located at addresses below the 4 GB boundary. Graphics applications, such as X and Xorg, map these graphics pages into their address space and thus have graphics mappings that are typically spread across the various NUMA nodes in the system. Since these mappings are locked down for I/O when a graphics application is executing, these pages may not be unmapped or freed by the memory-shielding support in the kernel, thus preventing any automatic page migration of these mappings.

To optionally place the preallocated graphics pages into a specific set of NUMA nodes as part of a memory-shielded NUMA node configuration, the following steps may be taken:

1. Stop all graphics (X/Xorg) activity. The system should be in at most init state 3 with no X activity.
2. Memory-shield one or more NUMA nodes with the **shield(1)** command.
3. Free all graphics pages by writing a zero to the **/proc/driver/graphics-memory** file. You may verify that all graphics pages have been freed by reading the **/proc/driver/graphics-memory** file at this point. Note that attempting to write a value of zero to this file will fail with an error if there are any graphics applications still making use of preallocated graphics pages. These applications need to be terminated before all pages can be successfully freed.
4. Create a shell (**bash**, **ksh**, etc.) with a **interleave** mempolicy that contains at least one CPU belonging to each of the NUMA nodes where you want the graphics pages to be allocated.
5. Re-allocate the graphics pages in the desired nodes by writing the new page count value to **/proc/driver/graphics-memory**.

You may validate that the pages were allocated in the desired NUMA nodes by reading the **/proc/driver/graphics-memory** file. The output from this read will provide per-node page allocation counts.

6. Return to init state 5 or restart the desired X activity.

Example

The following example creates a memory shielded node in the first node of a four NUMA node, quad-core, 16 CPU system. The graphics pages in this example are spread across all of the non-memory-shielded NUMA nodes: nodes 1 and 2. Note that in this example, the memory in node 3 is located above the 4 GB boundary, and thus no preallocated graphics pages reside in node 3.

1. Stop all graphics activity. Kill off or exit all X applications, X, Xorg, etc. For example, enter init state 3, when logged in as root:

```
# init 3
```

2. Memory shield the first node and check the configuration:

```
# /usr/bin/shield -m1 -a 0-3 -c
```

CPUID	irqs	ltmrs	procs	mem
0	yes	yes	yes	yes
1	yes	yes	yes	yes
2	yes	yes	yes	yes
3	yes	yes	yes	yes
4	no	no	no	no
5	no	no	no	no
6	no	no	no	no
7	no	no	no	no
8	no	no	no	no
9	no	no	no	no
10	no	no	no	no
11	no	no	no	no
12	no	no	no	no
13	no	no	no	no
14	no	no	no	no
15	no	no	no	no

3. Free up all the preallocated graphics pages. Verify that all pages have been freed by reading the **graphics-memory** file:

```
# /bin/cat /proc/driver/graphics-memory
```

```
Pre-allocated graphics memory:    10240 pages
Total allocated graphics memory:  10240 pages
Graphics memory in use:           0 pages
Maximum graphics memory used:     0 pages
```

	Node 0	Node 1	Node 2	Node 3
Preal:	5121	2712	2407	0
Total:	5121	2712	2407	0
InUse:	0	0	0	0
Max:	0	0	0	0

```
# /bin/echo 0 > /proc/driver/graphics-memory
```

```
# /bin/cat /proc/driver/graphics-memory
```

```
Pre-allocated graphics memory:    0 pages
Total allocated graphics memory:  0 pages
Graphics memory in use:           0 pages
Maximum graphics memory used:     0 pages
```

	Node 0	Node 1	Node 2	Node 3
Preal:	0	0	0	0
Total:	0	0	0	0

```
InUse:      0      0      0      0
Max:        0      0      0      0
```

4. Create a bash shell with an interleaved mempolicy that includes at least one CPU from both NUMA nodes 1 and 2. This will cause the page allocations to be spread out across the non-memshieded nodes. Check the new bash shell with the **run(1)** command's `--mempolicy view` option.

```
# /usr/bin/run --mempolicy interleave=4,8 bash
# /usr/bin/run --mempolicy view
Mempolicy  NextCpu  Cpus      Name
interleave 0x00f0    0x0ff0    run
```

5. Reallocate the graphics pages using the mempolicy bash shell. Verify the node locations of these allocations by reading the graphics-memory file:

```
# /bin/echo 10240 > /proc/driver/graphics-memory

# /bin/cat /proc/driver/graphics-memory
Pre-allocated graphics memory: 10240 pages
Total allocated graphics memory: 10240 pages
Graphics memory in use: 0 pages
Maximum graphics memory used: 0 pages
```

```
          Node 0  Node 1  Node 2  Node 3
Preal:    0     5120   5120    0
Total:    0     5120   5120    0
InUse:    0      0      0      0
Max:      0      0      0      0
```

6. Exit the interleave mempolicy bash shell:

```
# exit
```

7. Restart X, or return to init state 5:

```
# init 5
```

In the above example, you may change the nodes where the graphics pages are allocated by modifying the CPUs in the interleaved mempolicy in step 4 where the bash shell is invoked.

Note that the RedHawk kernel can be booted with the `no_pregraph_pgs` boot parameter to disable all preallocated graphics pages support.

NUMA Support for Processes using run(1)

The “mempolicy” option to **run(1)** can be used to establish a task-wide NUMA memory policy for the process about to be executed as well as display related information.

The synopsis is:

```
run [OPTIONS] COMMAND [ARGS]
```

“mempolicy” is one of the available *OPTIONS* and has the following forms:

```
--mempolicy=MEMPOLICY_SPECIFIER
-M MEMPOLICY_SPECIFIER
```

Note that a *PROCESS/THREAD_SPECIFIER*, which identifies the existing process or thread that **run** acts upon, cannot be used with the *mempolicy* option, which affects only the process(es) about to be created.

MEMPOLICY_SPECIFIER includes only one of the following. Each can be abbreviated to its initial unique character. *list* is a comma-separated list or range of CPUs; e.g., “0,2-4,6”. “active” or “boot” can be used to specify all active processors or the boot processor, respectively. An optional tilde [~] negates the list, although “active” cannot be negated.

[~]*list*

b[ind]=*list*

Executes the specified program using the MPOL_BIND memory policy using the memory local to the CPUs in *list*.

b[ind] Executes the specified program using the MPOL_BIND memory policy using memory local to the CPUs specified with the **--bias** option. The **--bias** option defines the CPUs on which the program is to run and must also be specified with this choice.

i[nterleave]=[~]*list*

Executes the specified program using the MPOL_INTERLEAVE memory policy using the memory local to the CPUs in *list*.

p[referred]=*cpu*

Executes the specified program using the MPOL_PREFERRED memory policy, preferring to use memory local to the single specified CPU.

p[referred]

Executes the specified program with the MPOL_PREFERRED task-wide NUMA memory policy, where the preferred memory is located on the node containing the CPU where the allocation takes place (a ‘local’ allocation policy).

d[efault]

Executes the specified program using the MPOL_DEFAULT memory policy. This is the default memory policy.

n[odes] Displays the CPUs included in each NUMA node along with total memory and currently free memory on each node. No other options or programs are specified with this invocation of **run**.

v[iew] Displays the memory policy setting of the current process. No other options or programs are specified with this invocation of **run**.

When a system contains one or more CPUs without local memory, these CPUs are assigned to a node in round-robin fashion during system initialization. Although assigned to a node, they do not actually have local memory and will always make non-local memory accesses, including memory accesses to their own assigned node. Under this type of configuration, **v[iew]** output will include an additional “NoMemCpus” column which will indicate the CPUs on each NUMA node that contain no local memory. It is recommended that hardware be configured so that each CPU has a memory module installed when using a NUMA-enabled kernel.

Specifying **run** with the **--mappings/-m** option on multi-node systems displays the number of user-mapped pages in each NUMA node for the processes or threads specified with the *PROCESS/THREAD_SPECIFIER* argument. This option cannot be used with a 'command' parameter at invocation.

Refer to the **run(1)** man page or the section “The run Command” in Chapter 4 for other options to **run**.

If **numactl(8)** is available on your system, it can also be used to set NUMA memory policies.

NUMA Support for Shared Memory Areas using **shmconfig(1)**

NUMA policies can be assigned to new shared memory areas or modified for existing shared memory areas using **shmconfig(1)** with the “mempolicy” option.

The synopsis is:

```
/usr/bin/shmconfig -M MEMPOLICY [-s SIZE] [-g GROUP] [-m MODE] [-u USER]  
[-o offset] [-S] [-T] {key | -t FNAME}
```

The “mempolicy” option has the following forms:

```
--mempolicy=MEMPOLICY  
-M MEMPOLICY
```

MEMPOLICY includes only one of the following. Each can be abbreviated to its initial unique character. *LIST* is a comma-separated list or range of CPUs; e.g., “0,2-4,6”. “active” or “boot” can be used to specify all active processors or the boot processor, respectively. An optional tilde [~] negates the list, although “active” cannot be negated.

To view the CPUs that are included in each node, and total and available free memory for each node, use **run -M nodes**.

[~]LIST

b[ind]=LIST

Sets the specified segment to the MPOL_BIND memory policy using the memory local to the CPUs in *LIST*.

i[nterleave]=[~]LIST

Sets the specified segment to the MPOL_INTERLEAVE memory policy using the memory local to the CPUs in *LIST*.

p[referred]=CPU

Sets the specified segment to the MPOL_PREFERRED memory policy, preferring to use memory local to the single specified CPU.

p[referred]

Sets the specified segment to the MPOL_PREFERRED NUMA memory policy, where the preferred memory is located on the node containing the CPU where the allocation takes place (a 'local' allocation policy).

d[efault]

Sets the specified segment to the MPOL_DEFAULT memory policy. This is the default.

v[iew] Displays the current memory policy setting for the specified segment.

Additional options that can be used with the mempolicy option include:

--size=SIZE

-s SIZE Specifies the size of the segment in bytes.

--offset OFFSET

-o OFFSET

Specifies an offset in bytes from the start of an existing segment. This value is rounded up to a pagesize multiple. If the **-s** option is also specified, the sum of the values of offset+size must be less than or equal to the total size of the segment.

--user=USER

-u USER Specifies the login name of the owner of the shared memory segment.

--group=GROUP

-g GROUP

Specifies the name of the group to which group access to the segment is applicable.

--mode=MODE

-m MODE Specifies the set of permissions governing access to the shared memory segment. You must use the octal method to specify the permissions; the default mode is 0644.

--strict

-S Outputs an error if any pages in the segment range do not conform to the specified memory policy currently being applied.

--touch

-T Causes a touch (read) to each page in the specified range, enforcing the memory policy early. By default, the policy is applied as applications access these areas and fault in/allocate the pages.

The *key* argument represents a user-chosen identifier for a shared memory segment. This identifier can be either an integer or a standard path name that refers to an existing file. When a pathname is supplied, an `ftok(key, 0)` will be used as the key parameter for the `shmget(2)` call.

--tmpfs=FNAME / -t FNAME can be used to specify a tmpfs filesystem filename instead of a key. The **-u**, **-g** and **-m** options can be used to set or change the file attributes of this segment.

Refer to the man page or the section “The shmconfig Command” in Chapter 3 for other options to **shmconfig**.

If **numactl(8)** is available on your system, it can also be used to set NUMA memory policies.

System Calls

The following system service calls are available. Note that the `numaif.h` header file should be included when making any of these calls. Refer to the man pages for details.

<code>set_mempolicy(2)</code>	Sets a task-wide memory policy for the current process.
<code>get_mempolicy(2)</code>	Gets the memory policy of the current process or memory address.
<code>mbind(2)</code>	Sets a policy for a specific range of address space, including shared memory.
<code>move_pages(2)</code>	Move a set of pages of a process to a different NUMA node.

Library Functions

The library, `/usr/lib64/libnuma.so`, offers a simple programming interface to the NUMA support. It contains various types of NUMA memory policy and node support routines and alternative interfaces for using the underlying NUMA system service calls. Refer to the `numa(3)` man page for details.

Informational Files and Utilities

The following sections describe files and utilities that can be used to display information relative to NUMA nodes.

Node Statistics

When NUMA is enabled in the kernel, each node has a set of information files in the subdirectory `/sys/devices/system/node/node#`, where `#` is the node number (0, 1, 2 etc.). These files are listed below.

<code>cpumap</code>	Displays a hexadecimal bitmap of the CPUs in this node; e.g. <pre>> cat /sys/devices/system/node/node3/cpumap 08</pre>
<code>cpulist</code>	Displays a list of CPUs in this node; e.g., <pre>> cat cpulist 4-7</pre>
<code>numastat</code>	Displays hit/miss statistics for the node. See the next section for explanations of the fields that are displayed.
<code>meminfo</code>	Displays various memory statistics for the node, including totals for free, used, high, low and all memory.

distance Displays the distance of each node's memory from the local node. A value of "10" indicates that the memory is local, and a value of "20" indicates that the memory is one hyperchannel connection away, for example.

cpu# These are the CPU device files associated with the node; e.g.

```
$ ls -l /sys/devices/system/node/node3/cpu3
lrwxrwxrwx 1 root root 0 jan 21 03:01 cpu3
->../../../../devices/system/cpu/cpu3
```

Node IDs for Mapped Pages

numapgs (1) displays the location by NUMA node ID of each page currently mapped into a specified process or thread. Only locations that have mappings to physical memory pages are output, unless the **-a** option is specified.

Syntax:

numapgs [*OPTIONS*]

OPTIONS include:

--pid=pid, -p pid

The process ID or thread ID whose address space is to be displayed.

--start=saddr, -s saddr

To limit the range of mappings to be displayed, no node IDs for mappings below this *saddr* hexadecimal virtual address value will be displayed. If **--end** is not specified, all node ID entries from *saddr* to the end of the address space are displayed.

--end=eaddr, -e eaddr

To limit the range of mappings to be displayed, no node IDs for mappings at or above this *eaddr* hexadecimal virtual address value will be displayed. If **--start** is not specified, all node ID entries from the beginning of the address space up to *eaddr*-1 are displayed.

--all, -a

Display all virtual address page locations in the process' address instead of only those locations containing valid mappings to physical memory. A period (.) in the output represents locations with no mappings or mappings to non-memory objects (such as I/O space mappings). This option can be used with **--start** or **--end** to display all page locations within the specified range.

--version, -v

Display the current version of **numapgs**, then exit.

--help, -h

Display available options, then exit.

Each output line contains up to eight decimal node ID values.

If the page is currently locked (through `mlock(2)` or `mlockall(2)`), an “L” will appear to the right of the NUMA node ID value. If the page is currently replicated (see “Memory-shielded Nodes”), an “R” will appear to the right of the NUMA node ID value.

Below is a sample extract of `numapgs` output for a process that has all its pages locked using `mlockall(2)` as shown by the L beside each node ID value. Replicated pages are represented by the R next to their node ID value.

```
3a9b000000-3a9b12b000 r-xp /lib64/tls/libc-2.3.4.so
 3a9b000000:    0L   0L   0L   0L   0L   0L   0L   0L
 3a9b008000:    0L   0L   0L   0L   0L   0L   0L   0LR
 3a9b010000:    0L   0L   0L   0L   0L   0L   0L   0L
```

NUMA Hit/Miss Statistics Using numastat

`numastat` is a script that combines the information from all the nodes’ `/sys/devices/system/node/node#/numastat` files:

```
$ numastat
node 3      node 2      node 1      node 0
numa_hit    43674      64884      79038      81643
numa_miss     0           0           0           0
numa_foreign  0           0           0           0
interleave_hit 7840       5885       4975       7015
local_node   37923      59861      75202      76404
other_node   5751       5023       3836       5239
```

`numa_hit` the number of successful memory allocations made from the node

`numa_miss` the number of memory allocations that could not be made from the node but were instead allocated for another node

`numa_foreign` the number of allocations that failed to allocate memory from a node but were instead allocated from this node

`interleave_hit` the number of successful interleaved memory allocations made from this node

`local_node` the number of memory allocations that were made from the local node

`other_node` the number of memory allocations that were made to a non-local node

kdb Support

The following `kdb` commands have been added or modified to support NUMA. Note that this additional support is only present when the kernel is configured with NUMA support enabled.

`memmap [node_id]` outputs information for all pages in the system, or for only the specified node

`task` additionally outputs the mempolicy and `il_next` task structure fields

mempolicy <i>addr</i>	outputs information for the specified mempolicy structure
pgdat [<i>node_id</i>]	decodes the specified node's zonelists, or if <i>node_id</i> is not specified, zone 0
vmp -v	additionally outputs mempolicy information for virtual memory areas

Performance Guidelines

Through CPU shielding, CPU biasing and binding an application to specific NUMA nodes, page allocations can be made in the most efficient manner on NUMA systems. Guidelines for working with tasks and shared memory areas are given below.

Task-Wide NUMA Mempolicy

The MPOL_BIND policy is usually the most useful policy for time-critical applications. It is the only policy that lets you deterministically specify the node(s) for page allocations. If the memory allocation cannot be made from the specified node or set of specified nodes, the program will be terminated with a SIGKILL signal.

By combining CPU shielding and CPU biasing with the MPOL_BIND memory policy, a shielded CPU can be created and the application executed on the shielded CPU where the pages for that application will be allocated only from the shielded CPU's NUMA node. Note that pre-existing shared text page sand copy on write data pages may not be local, although copy on write data pages will become local once they are written to.

The **run(1)** command can be used to start up an application on a shielded CPU with the MPOL_BIND memory policy. Alternatively, since pages that are already present in an application's address space are not affected by any subsequent change of NUMA memory policy, the application can set its CPU affinity and NUMA memory policy as soon as possible after it has begun executing with **mpadvise(3)** and **set_mempolicy(2)** or NUMA library function calls.

The following example shows how to use the **run(1)** command bias and mempolicy options to start up an application on a shielded CPU with the MPOL_BIND memory policy with memory allocations coming only from the NUMA node where CPU 2 resides:

```
$ shield -a 2
$ run -b 2 -M b my-app
```

For more information about shielded CPUs and the **shield(1)** command, see Chapter 2 and the **shield(1)** man page.

Shared Memory Segments

It is also generally recommended that the MPOL_BIND memory policy be used for shared memory segments. A shared segment's NUMA memory policy can be specified with the **mbind(2)** system service call or with the **shmconfig(1)** utility.

If a shared memory segment is to be referenced from multiple CPUs, it is possible to specify different MPOL_BIND mempolicy attributes for different portions of a shared memory area in order to maximize memory access performance.

As an example, consider a “low” application that mainly writes to the lower half of a shared memory segment, and a “high” application that mainly writes to the upper half of the same shared memory segment.

1. Create a shared memory segment with a key value of ‘123’. Change the lower half of the segment to use the MPOL_BIND memory policy with CPU 2’s NUMA node for page allocations, and the upper half to use MPOL_BIND with CPU 3’s node for page allocations.

```
$ shmconfig -s 0x2000 123
$ shmconfig -s 0x1000 -M b=2 123
$ shmconfig -o 0x1000 -M b=3 123
```

2. Shield both CPUs 2 and 3.

```
$ shield -a 1,2
```

3. Start up the “low” application on CPU 2 with a MPOL_BIND mempolicy using CPU 2’s NUMA node for memory allocations, and start up the “high” application on CPU 3 with a MPOL_BIND mempolicy using CPU 3’s NUMA node for memory allocations.

```
$ run -b 2 -M b low
$ run -b 3 -M b high
```

Configuration

Only the AMD Opteron and Intel Nehalem processors have NUMA architecture. The following kernel parameters affect processing on NUMA nodes. All these parameters are enabled by default in RedHawk pre-built kernels (though some apply to only 32-bit mode and some apply to only 64-bit mode).

NUMA and ACPI_NUMA (all modes), X86_64_ACPI_NUMA and K8_NUMA (64-bit mode only)

These kernel parameters must be enabled for NUMA kernel support. They are accessible under the **Processor Type and Features** selection in the Kernel Configuration GUI and are enabled by default in all pre-built RedHawk kernels.

Note that there is a boot option, `numa=off`, that can be specified at boot time that will disable NUMA kernel support on a NUMA system. This will create a system with a single node, with all CPUs belonging to that node. It differs from NUMA support not being built into the kernel, in which case there is a flat memory system with no nodes and where the NUMA user interfaces will return errors when called.

When using a NUMA enabled kernel on an AMD Opteron or Intel Nehalem system, the following hardware recommendations are made:

- It is highly recommended that a memory module be installed for each CPU in the system. Otherwise, CPUs without a local memory module must remotely access other memory modules for every memory access, thus degrading system performance.
- Any BIOS-supported memory module interleaving hardware support should be disabled in the BIOS. If not disabled, NUMA support in a NUMA enabled kernel will be disabled, resulting in a single NUMA node containing all the CPUs in the system.

PAGE_REPLICATION When enabled, pagecache replication support is compiled into the kernel. Depending upon the setting for **PAGE_REPLICATION_DYNAMIC** (see below), pagecache replication is always active on the system from the time the system is booted, or is inactive until manually activated.

PAGE_REPLICATION_DYNAMIC When enabled along with **PAGE_REPLICATION**, pagecache replication is not active at system boot, but can be manually activated by writing a one (1) to **/proc/sys/vm/page_replication_enabled** or by using **shield(1)** to create one or more memory-shielded NUMA nodes.

When disabled and **PAGE_REPLICATION** is enabled, pagecache replication is always active on the system from the time the system is booted.

MEMSHIELD_ZONE_NORMAL (32-bit mode only) When enabled on 32-bit mode NUMA kernels, setup the zonelists so that a local node's normal zone pages (if any) are used before selecting a remote node's highmem zone page. The local node's highmem zone pages are still used up first. This feature can be disabled in RedHawk 32-bit mode pre-built kernels with the "prefer_highmem" grub kernel boot option.

MEMSHIELD_ZONELIST_ORDER When enabled, NUMA node zonelists will be reordered when one or more NUMA nodes become memory shielded. These zonelists control the node search order for available memory when the local node's memory resources become low. The zonelists are reordered such that when a local node cannot satisfy a memory allocation request, memory from other non-shielded nodes will be used before resorting to using the memory of a memory shielded node(s). When there are no more memory shielded nodes in the system, the original zonelist ordering will be automatically restored.

Configuring and Building the Kernel

This chapter provides information on how to configure and build a RedHawk Linux kernel.

Introduction

The RedHawk kernels are located in the `/boot` directory. The actual kernel file names change from release to release, however, they generally have the following form:

`vmlinuz-kernelversion-RedHawk-x.x[-flavor]`

<i>kernelversion</i>	is the official version of Linux kernel source code upon which the RedHawk kernel is based (may contain suffixes such as <code>-rc1</code> or <code>-pre7</code>)
<i>x.x</i>	is the version number of the RedHawk kernel release
<i>flavor</i>	is an optional keyword that specifies an additional kernel feature that is provided by the specific kernel

The kernel is loaded into memory each time the system is booted. It is a nucleus of essential code that carries out the basic functions of the system. The kernel remains in physical memory during the entire time that the system is running (it is not swapped in and out like most user programs).

The exact configuration of the kernel depends upon:

- a large number of tunable parameters that define the run-time behavior of the system
- a number of optional device drivers and loadable modules

Kernel configuration, or reconfiguration, is the process of redefining one or more of these kernel variables and then creating a new kernel according to the new definition.

In general, the supplied kernels are created with tunable parameters and device drivers that are suitable for most systems. However, you may choose to reconfigure the kernel if you want to alter any of the tunable parameters to optimize kernel performance for your specific needs.

After you change a tunable parameter or modify the hardware configuration, the kernel will need to be rebuilt, installed and rebooted.

Configuring a Kernel Using `ccur-config`

The RedHawk Linux product includes several pre-built kernels. The kernels are distinguished from each other by their “*flavor*” suffix. The following flavors are defined:

<code>generic</code> (no suffix)	The generic <=4GB kernel. This kernel is the most optimized and will provide the best overall performance, however it lacks certain features required to take full advantage of the NightStar RT tools.
<code>trace</code>	The trace kernel. This kernel is recommended for most users as it supports all of the features of the generic kernel and in addition provides support for the kernel tracing feature of the NightTrace RT performance analysis tool.
<code>debug</code>	The debug kernel. This kernel supports all of the features of the trace kernel and in addition provides support for kernel-level debugging. This kernel is recommended for users who are developing drivers or trying to debug system problems.

Each pre-built kernel has an associated configuration file that captures all of the details of the kernel's configuration. These files are located in the `configs` directory of the kernel source tree. For the pre-built kernels, the configuration files are named as follows:

On an `i386` architecture (32-bit):

generic kernel	<code>static.config</code>
trace kernel	<code>trace-static.config</code>
debug kernel	<code>debug-static.config</code>

On an `x86_64` architecture (64-bit):

generic kernel	<code>static-x86_64.config</code>
trace kernel	<code>trace-static-x86_64.config</code>
debug kernel	<code>debug-static-x86_64.config</code>

In order to configure and build a kernel that matches one of the pre-built kernels, you must `cd` to the top of the kernel source tree and run the `ccur-config(8)` tool.

NOTE

The `ccur-config` script must be run as root. If kernel modifications are to be made, the system must be in graphical mode (i.e. run-level 5) or a valid `DISPLAY` variable must be set.

The following example configures the kernel source tree for building a new kernel based on the RedHawk Linux 5.2 trace kernel's configuration. Note that it is not necessary to specify the “`.config`” suffix of the configuration file as that is automatically appended.

```
# cd /usr/src/linux-2.6.26.6-RedHawk5.2
# ./ccur-config trace-static
```

ccur-config can also be used for customized kernels by specifying the appropriate custom config file residing in the **configs** directory. The **-k name** option can be used to name a new flavor, and the **-s** option saves the configuration file in the **configs** directory. For example:

```
# ./ccur-config -s -k test debug-static
```

configures a kernel with **-test** as the flavor suffix that is based on the RedHawk i386 **debug-static** kernel and saves the resulting configuration as **configs/test.config**.

During the execution of **ccur-config** you will be presented with a graphical configuration interface (GUI) in which you can customize many different aspects of the RedHawk Linux kernel. See Screen 11-1 for an example of the Kernel Configuration GUI.

The **Save** selection from the **File** menu must be selected to save your changes and exit the program. Note that even if you do not change any configuration parameters, it is still necessary to select **Save** in order to properly update the kernel's configuration files.

An exhaustive list of the settings and configuration options that are available via the graphical configuration window is beyond the scope of this document, however many tunable parameters related to unique RedHawk features and real-time performance are discussed throughout this manual and listed in Appendix B. In addition, when the parameter is selected, information about that parameter is displayed in a separate window of the GUI.

If you do not wish to change kernel parameters, specify the **-n** option to **ccur-config** and the GUI will not appear.

Screen 11-1 Kernel Configuration GUI

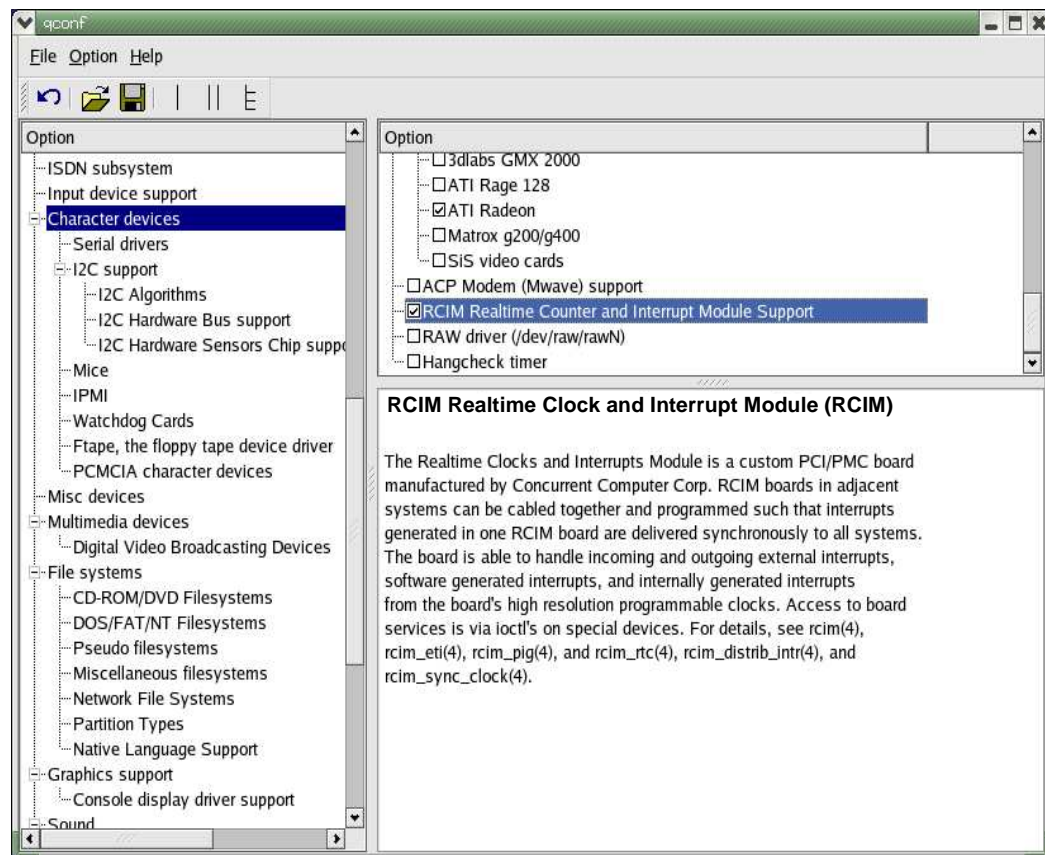

Building a Kernel

Regardless of which kernel configuration is used, the resulting kernel will be named with a “vmlinuz” prefix followed by the current kernel version string as it is defined in the top-level **Makefile**, followed with a “-custom” suffix added. For example:

```
vmlinuz-2.6.25.6-RedHawk-5.2-custom
```

The final suffix can be changed by specifying the **-k name** option to **ccur-config**. This defines *name* as the REDHAWKFLAVOR variable in the top-level **Makefile**, which remains in effect until changed again with **-k** or by editing **Makefile**. When building multiple kernels from the same kernel source tree, it is important to change the suffix to avoid overwriting existing kernels accidentally.

NOTES

The pre-built kernels supplied by Concurrent have suffixes that are reserved for use by Concurrent. Therefore, you should *not* set the suffix to: (empty string), “-trace”, or “-debug”.

Use the **ccur-config -c** option if you need to build driver modules for a kernel (see the section “Building Driver Modules” later in this chapter).

Once kernel configuration has completed, a kernel can be built by issuing the appropriate **make(1)** commands. There are many targets in the top-level **Makefile**, however the following are of special interest:

make bzImage	Build a standalone kernel.
make modules	Build any kernel modules that are specified in the kernel configuration.
make modules_install	Install modules into the module directory associated with the currently configured kernel. Note that the name of this directory is derived from the kernel version string as defined in the top-level Makefile . For example, if the REDHAWKFLAVOR is defined as “-custom” then the resulting modules directory will be “ /lib/modules/kernelversion-RedHawk-x.x-custom ”.
make install	Install the kernel into the /boot directory along with an associated System.map file.

NOTE

To completely build and install a new kernel, all of these **Makefile** targets must be issued in the order shown above.

For an example of a complete kernel configuration and build session, refer to Figure 11-1.

Figure 11-1 Example of Complete Kernel Configuration and Build Session

```

# cd /usr/src/linux-2.6.26.6-RedHawk-5.2
# ./ccur-config -k test debug-static
Configuring version: 2.6.26.6-RedHawk-5.2-test
Cleaning source tree...
Starting graphical configuration tool...
[ configure kernel parameters as desired ]

Configuration complete.

# make bzImage
# make modules
# make modules_install
# make install
[ edit /etc/grub.conf to reference new kernel and reboot ]

```

Building Driver Modules

It is often necessary to build driver modules for use with either one of the pre-existing kernels supplied by Concurrent or a custom kernel.

To build driver modules for a kernel, the following conditions must be met:

- The desired kernel must be the currently running kernel.
- The kernel source directory must be configured properly for the currently running kernel via **ccur-config**.

Note that if a custom kernel was built using the procedure outlined in the section “Building a Kernel,” then the kernel source directory is already configured properly and running **ccur_config** is not necessary.

The **-c** option to **ccur-config** can be used to ensure that the kernel source directory is properly configured. This option automatically detects the running kernel and configures the source tree to properly match the running kernel. Driver modules can then be properly compiled for use with the running kernel.

NOTE

The **-c** option to **ccur_config** is only intended for configuring the kernel source tree to build driver modules and should not be used when building a new kernel.

The **-n** option to **ccur_config** can also be specified when it is not necessary to change configuration parameters. With **-n**, the configuration GUI does not appear and no configuration customization is performed.

See the next section for an example of building a dynamic load module into a pre-built RedHawk kernel.

Example—Building a Dynamic Loadable Module in a Pre-built RedHawk Kernel

Adding functionality to a RedHawk system is attained by placing additional hardware controllers into the system. It is not necessary to make a custom kernel to add support for new hardware devices, unless there is a requirement for a static kernel driver.

The following example adds a Control RocketPort serial card support to a RedHawk system. The source for the Control RocketPort driver is contained in the RedHawk kernel source tree.

The RedHawk **trace** kernel is the running kernel in this example.

1. Run **ccur-config** to configure the kernel source tree.
Note that *kernelname* is the 'uname -r' output of the running kernel:

```
# cd /lib/modules/kernelname/build
# ./ccur-config -c
```

2. In the GUI window, set Device Drivers ->Character Devices->Non-standard serial port support->Control RocketPort support to a value of "M" (module). See Screen 11-2 for an illustration of the GUI (showing the Show Name, Show Range and Show Data Options selected).
3. Save the configuration, and exit the GUI.

Screen 11-2 Kernel Configuration GUI Adding Serial Card Support

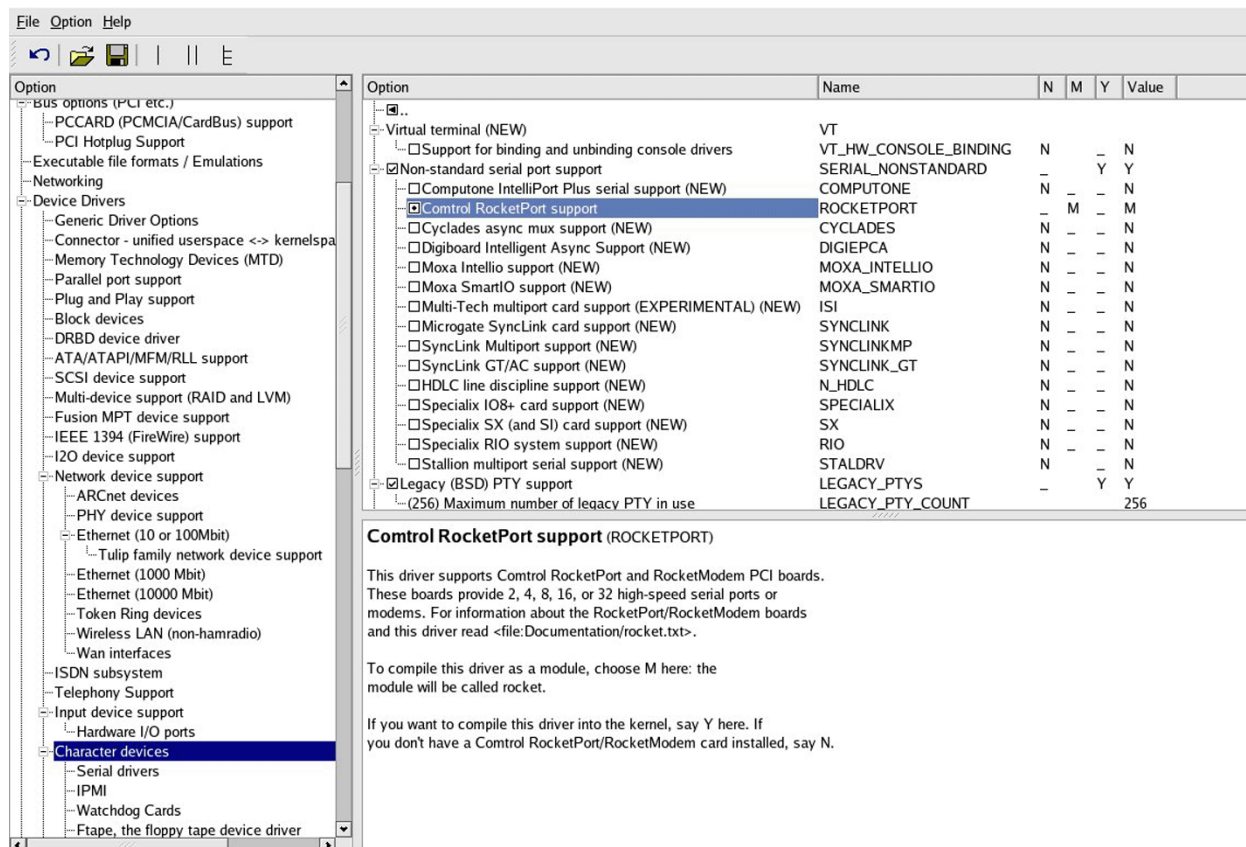

4. Run **make** to build the new kernel module:

```
# make REDHAWKFLAVOR=-trace modules
```

5. When the make completes, locate the rocket driver in the output; e.g.:

```
LD [M] drivers/char/rocket.ko
```

and copy it as follows:

```
# mkdir /lib/modules/kernelname/kernel/extras
# cp drivers/char/rocket.ko /lib/modules/kernelname/kernel/extras/
```

6. Set up the dependency files used by **modprobe(8)** to load modules.

```
# depmod
```

7. The file **/lib/modules/kernelname/build/Documentation/rocket.txt** contains configuration requirements pertaining to the Control RocketPort card. Device entries can be created and the driver loaded automatically by inserting the appropriate commands, **MAKEDEV(8)** and **modprobe(8)**, into the file **/etc/rc.modules** which will be executed when the kernel initializes.

- a. Insert the following alias into **/etc/modprobe.conf**:

```
alias char-major-46 rocket
```

- b. If the file **/etc/rc.modules** does not exist on your system it must be created. It should have file permissions of 0x755 in order to function. Include the following in the file:

```
#!/bin/bash
/sbin/MAKEDEV ttyR
modprobe rocket
```

For an example of adding a driver that is not in the kernel source tree, see **/usr/share/doc/ccur/examples/driver** on your RedHawk system.

Additional Information

There are many resources available that provide information to help understand and demystify Linux kernel configuration and building. A good first step is to read the **README** file located in the top-level of the installed RedHawk kernel source tree. In addition, the following HOWTO document is available via The Linux Documentation Project web site: <http://www.tldp.org/HOWTO/Kernel-HOWTO.html>

This chapter describes the tools provided in RedHawk Linux for kernel debugging and crash dump analysis.

Overview

Several open source patches with Concurrent enhancements are incorporated into RedHawk for kernel problem analysis.

The enhanced kernel debugger, **kdb**, is provided in the RedHawk “debug” kernels.

An enhanced linux kernel **kexec**-based crash dump (**kdump**) mechanism along with the **crash(8)** utility for reading crash dumps are used to take and analyze system crashes. **Crash** can also analyze live memory. Note that LKCD and **lcrash** facilities are no longer supported.

The sections below describe crash dump and analysis RedHawk systems.

Taking and Analyzing a System Crash

RedHawk includes **kdump(8)**, a **kexec**-based crash dump service that is used to take a crash dump and the **crash(8)** utility that can be used to analyze the dump. These are described in the following sections.

Activating kdump

The **/etc/sysconfig/kdump** configuration file contains definitions that control how **kdump** starts and operates.

kdump is activated through the setting **ACTIVE=1** in **/etc/sysconfig/kdump**. This is the default setting. Editing the file or issuing the command **service kdump on** sets **ACTIVE=1** in the file. Conversely, **kdump** can be deactivated by editing the file and setting **ACTIVE=0** or by running **service kdump off**.

By default, the **kdump** service starts from **rc.sysinit**. This is the only way **kexec**-based crash dumps can be supported in single user mode and also ensures readiness at the earliest possible time.

A LATE startup option can be set for diskless environments such as in a cluster where file systems/paths needed by **kdump** are not mounted until after other services have started.

Refer to the section “kdump Options Defined in the Configuration File” for more information about how to use `/etc/sysconfig/kdump`.

How a Crash Dump is Created

kdump prepares the environment of the running kernel to save a small set of crash files for analysis in the event of a kernel panic. The **crash** utility needs debug information in order to read a crash dump virtual memory image “vmcore” file. The debug information is contained in the **vmlinux** image of the running kernel when built with the `DEBUG_INFO` option. The **vmlinux** image is called a *namelist*.

If the `crashkernel=size@16M` boot parameter is specified and `ACTIVE=1` is defined in the `/etc/sysconfig/kdump` configuration file, the **kdump** service presaves a link to the matching kernel **vmlinux** image (namelist) along with the kernel `/proc/config.gz` file in the `/kdump/kerninfo` directory. It then preloads the crash kernel using `kexec -p` (see `kexec(8)`).

The **kdump** service constructs a string based on the values set in `/etc/sysconfig/kdump` which is provided to the `kexec -p` command. The default string specifies the installed RedHawk crash kernel, tells the crash kernel to use the current root file system and console device, and passes along the boot parameters `maxcpus=1 irqpoll 1`. If no `crashkernel` boot parameter is issued, the **kdump** service skips all setup. You can use the `service kdump echo` command to view a dry run of the `kexec -p` command.

After successfully loading the crash kernel, the system reboots into the crash kernel if a system crash is triggered. Trigger points are located in `panic()`.

The following conditions will execute a crash trigger point:

- A kernel panic occurs.
- `/proc/sys/kernel/panic_on_oops` is set and an oops occurs.
- `/proc/sys/vm/panic_on_oom` is set and an out of memory condition occurs.
- `/proc/sys/kernel/unknown_nmi_panic` is set and an unknown NMI occurs.
- `/proc/sys/kernel/unknown_nmi_panic` is set and the NMI button is pressed. Refer to the section “NMI Button” below for more information.
- `/proc/sys/kernel/sysrq` is set and `Alt-Sysrq-c` is issued from the keyboard.
- `/proc/sys/kernel/sysrq` is set and `echo c > /proc/sysrq-trigger` is issued.
- The `kdump` command is issued from the `kdb` prompt.

Installation/Configuration Details

The `ccur-kexec-tools-kexec-version-kdump` rpm installs two binary executable files, `/sbin/kexec` and `/sbin/kdump`, as well as the `/etc/init.d/kdump` service and its configuration file, `/etc/sysconfig/kdump`. The `kexec(8)` and `kdump(8)` man pages are also installed with this rpm.

The following are requirements to enable the system to take and analyze crash dumps. The kernel configuration parameters are included by default in all pre-built RedHawk kernels.

- The running kernel (the kernel to be debugged) must be built with the `KEXEC` and `DEBUG_INFO` kernel parameters, under **Processor Type and Features** in the Kernel Configuration GUI, set to `Y`.
- The crash kernel must be built with `KEXEC` and `CRASH_DUMP` kernel parameters, under **Processor Type and Features** in the Kernel Configuration GUI, set to `Y`.
- The kernels must be booted with the `crashkernel=size@16M` boot option. This specifies the memory reservation and offset where the crash kernel will be booted upon kernel panic.
- Via `/etc/sysconfig/kdump`, options define the behavior of the `kdump` service. See the section “kdump Options Defined in the Configuration File” below for information.

A custom kernel based on a pre-built RedHawk 4.2 or later kernel config file using `ccur-config(8)` and `make install` will meet all requirements for using `kdump` and `crash`. If using a separate custom kernel, ensure all the requirements above are met. See Chapter 11, *Configuring and Building the Kernel*, for more information about building a custom kernel.

kdump Options Defined in the Configuration File

The actions taken by the `kdump` service are determined by the options set in the `kdump` configuration file `/etc/sysconfig/kdump`. The file is fully commented with information describing the options and recommendations for setting values.

Current settings can be viewed using the `config` argument to `kdump` (see the section “kdump Command Line Interface” below).

By default, `kdump` is not active. To activate `kdump`, set `ACTIVE=1` in the configuration file or issue the command `service kdump on`, which sets `ACTIVE=1` in the configuration file.

With `kdump` active, the following occurs by default:

- The `kdump` service starts from `rc.sysinit`.

A `LATE` startup option can be set for diskless environments such as in a cluster where file systems/paths needed by `kdump` are not mounted until after other services have started. When you set `LATE=1`, the `kdump` service starts up with the following defaults as defined by `chkconfig(8)`: `12345 26 95`. This means that the service is active in runlevels 1, 2, 3, 4 and 5, and that it starts

with a priority of 26 and stops with a priority of 95. Use the `LEVELS`, `START`, and `STOP` options in the `kdump` config file to change these values. DO NOT DIRECTLY EDIT the `kdump` service `init` script as you would with a normal `init` script. Use the `kdump status` command to see the current `kdump` startup configuration (see the section “`kdump` Command Line Interface” below).

- The `namelist` setup is performed and the crash kernel is preloaded. If `crashkernel=size@16M` is not specified at boot time, no action is performed.
- By default, a dump is taken on kernel panic, dump on oops (`PANIC_ON_OOPS=1`) and out-of-memory (`PANIC_ON_OOM=1`). Options can be set to force a dump on unknown NMI (`UNKNOWN_NMI_PANIC`) also. If desired, these options can be unset so that a dump is taken only on kernel panic.
- `Kexec` is used to start the crash kernel at run level 1 using the current root file system and console device.
- Crash files are saved to disk using `gzip` compression.
- A reboot is performed immediately after crash files are saved. An option can be set for the kernel to remain running and not reboot after the save.

These actions and others can be customized by editing `/etc/sysconfig/kdump`. Additional options include:

- specifying a custom crash kernel and custom `initrd` when needed
- specifying a different root file system, `kerninfo` directory, console, save directory, compression or run level
- not saving the crash file, saving via `scp` or saving across NFS with all appropriate settings
- providing a script to customize after-panic actions

After making modifications to `/etc/sysconfig/kdump`, run the following:

```
# service kdump restart
```

kdump Command Line Interface

In addition to starting, stopping, restarting and reloading the `kdump` service, other `kdump` commands query the system and facilitate debugging configuration problems.

The `kdump` service takes arguments in the following form:

```
# service kdump arg
```

where `arg` includes:

help	displays a brief description of the arguments
start	reloads the crash kernel if configured properly, otherwise executes the configured <code>crashkernel</code> routine if the crash kernel is running
stop	cleans up and unloads the crash kernel

restart or reload	calls stop then start
config	displays the current valid kdump configuration values set in /etc/sysconfig/kdump after initialization
on	enables the start/stop/restart/reload actions
off	disables the start/stop/restart/reload actions
echo	displays a “dry run” echo of the crash kernel kexec string
stat	displays the readiness of the kernel for kdump start/stop/restart/reload actions plus system information that includes architecture, kernel name, uptime, current runlevel, system RAM, parsed /proc/cmdline , kexec build options, the readiness of the system to kexec the crashkernel, nmi button dump response and active sysrq and panic triggers.
status	displays the on/off status of kdump and when it starts during boot. For example: With ACTIVE=1 and LATE=0 (starts from rc.sysinit): <pre># service kdump status kdump rc:on 0:off 1:off 2:off 3:off 4:off 5:off 6:off 26 95</pre> With ACTIVE=1 and LATE=1 (starts as a normal service): <pre># service kdump status kdump rc:off 0:off 1:on 2:on 3:on 4:on 5:on 6:off 26 95</pre> Note that the two numbers at the end of the status line indicate the start and stop priorities as used by chkconfig(8) . The start priority is “26” and the stop priority is “95”.
files	displays the crash file save directory location, file system, total size, size of individual dumps and statistics on local file system usage.
setup	set up scp server for password free scp save option

Using crash to Analyze the Dump

Crash can be run on a dump file or on a live system. **Crash(8)** commands consist of common kernel core analysis tools such as kernel stack back traces of all processes, source code disassembly, formatted kernel structure and variable displays, virtual memory data, dumps of linked-lists, etc., along with several commands that delve deeper into specific kernel subsystems. Relevant **gdb** commands may also be entered, which in turn are passed on to the **gdb** module for execution.

Analyzing a Dump File

To run **crash** on a dump file, at least two arguments are required:

- The kernel object filename, referred to as the kernel *namelist*. This file is named **vmlinux** and is copied to the **/kdump/date-time**

- The dump file named **vmcore**.

In the event of a kernel panic, invoke **crash** as shown below. The arguments can be supplied in any order.

```
# cd /kdump/date-time
# pwd
/kdump/02-27-08.0711.04
# ls
config.gz vmcore.gz vmlinux.gz
# gunzip *
# crash vmlinux vmcore
```

If the files are compressed,
unzip them before using **crash**

```
KERNEL: vmlinux
DUMPFILE: vmcore
CPUS: 4
DATE: Tue Feb 27 07:11:04 2008
UPTIME: 00:02:34
LOAD AVERAGE: 0.12, 0.59, 0.46
TASKS: 85
NODENAME: ihawk
RELEASE: 2.6.26.6-RedHawk-5.2-trace
VERSION: #1 SMP PREEMPT Tue Feb 13 14:25:24 EST 2008
MACHINE: i686 (3046 Mhz)
MEMORY: 1 GB
PANIC: "SysRq : Trigger a crashdump"
PID: 4236
COMMAND: "crashme"
TASK: f787acd0 [THREAD_INFO: f5582000]
CPU: SysRq : Trigger a crashdump
STATE: TASK_RUNNING (SYSRQ)

crash>
```

Analyzing a Live System

To run **crash** on a live system, specify no arguments. **Crash** searches for the **vmlinux** file and opens **/dev/mem** as the memory image:

```
# crash

KERNEL: /boot/vmlinux-2.6.26.6-RedHawk-5.2-trace
DUMPFILE: /dev/mem
CPUS: 16
DATE: Tue Feb 27 15:32:45 2008
UPTIME: 1 days, 06:36:30
LOAD AVERAGE: 0.45, 1.06, 0.96
TASKS: 258
NODENAME: ihawk
RELEASE: 2.6.26.6-RedHawk-5.2-trace
VERSION: #1 SMP PREEMPT Tue Feb 20 18:11:17 EST 2008
MACHINE: i686 (2660 Mhz)
MEMORY: 4 GB
PID: 32078
COMMAND: "crash"
TASK: f7aac0b0 [THREAD_INFO: e6e64000]
CPU: 8
STATE: TASK_RUNNING (ACTIVE)

crash>
```

Getting Help

Online help for **crash** is available through the following actions:

- Specify **help** at the `crash>` prompt to display a list of crash commands, each with a link to display the help page on that command.
- Specify **crash -h** at the system prompt to display a full help screen listing all available options.
- Specify **crash -h [opt]** at the system prompt to view the help page on the command specified by *opt*.

More information about **crash(8)** is available on the man page and at the following web site: http://people.redhat.com/anderson/crash_whitepaper/index.html.

Kernel Debuggers

The Linux kernel debugger, **kdb**, is provided in the pre-built RedHawk “debug” kernels.

kdb

The **kdb** debugger allows the programmer to interactively examine kernel memory, disassemble kernel functions, set breakpoints in the kernel code and display and modify register contents.

kdb is configured by default in the RedHawk debug kernel. **kdb** is automatically invoked upon system panic, if the PAUSE key is pressed or CTRL-A is entered on the serial console.

While **kdb** does have some support for USB keyboards, it is found not to be reliable and is not supported in the RedHawk debug kernel. On systems with a USB keyboard, it is recommended that a serial console be configured and **kdb** used over the serial port. See Appendix H for instructions for setting up the serial console.

On systems having an NMI button, a debug kernel can be configured that allows pressing the NMI button to enter **kdb** and take a crash dump when exiting (see the section “NMI Button” below). The `kdump` command to **kdb** can also be used to request a **kdump** crash dump.

The `kdb=off` boot command disables entry into **kdb**. The `kdb=early` boot command makes the kernel enter **kdb** early in the boot process.

Information about using **kdb** is beyond the scope of this document. Refer to documentation at `/kernel-source/Documentation/kdb`.

NMI Interrupts

The Linux NMI watchdog feature generates “watchdog” NMI interrupts. NMIs (non-maskable interrupts) execute even if the system is locked up hard. By executing periodic NMI interrupts, the kernel can monitor whether any CPU has locked up and prints out debugging messages if it has.

Enabling NMI watchdog support is done with the `nmi_watchdog=N` boot command line parameter. `nmi_watchdog=0` disables NMI watchdog interrupts. When $N = 1$, each CPU performs its own NMI timing (currently this setting does not work and is changed to $=2$); when $N = 2$, generated NMIs are sent to all CPUs via a broadcast. `nmi_watchdog=-1` can be used on x86_64 kernels, which lets the kernel select the mode (1 or 2).

By default, `nmi_watchdog` is turned on in the RedHawk debug kernels (`nmi_watchdog=2` for i386; `nmi_watchdog=-1` for x86_64) and turned off in all other RedHawk kernels.

More information about the NMI watchdog feature can be found at */kernel-source/Documentation/nmi_watchdog.txt*.

NMI Button

Some systems have an NMI button. By default, it does not function. The problem lies in the fact that an NMI cannot be determined to be the result of pressing the NMI button or the periodic NMI watchdog.

In order to have the NMI button do something useful, the NMI watchdog must be disabled. This is accomplished via the `nmi_watchdog=0` boot command. This will cause **kdb** to be entered when the button is pressed. The **kdb** `kdump` command can be used to capture a crash dump if this is desired.

Using the `nmi_dump` boot command will also trigger a **kdump** crash dump to be captured (when the system is properly configured and the kernel has been loaded). See “How a Crash Dump is Created” on page 12-2.

Pluggable Authentication Modules (PAM)

This chapter discusses the PAM facility that provides a secure and appropriate authentication scheme accomplished through a library of functions that an application may use to request that a user be authenticated.

Introduction

PAM, which stands for Pluggable Authentication Modules, is a way of allowing the system administrator to set authentication policy without having to recompile authentication programs. With PAM, you control how the modules are plugged into the programs by editing a configuration file.

Most users will never need to touch this configuration file. When you use `rpm(8)` to install programs that require authentication, they automatically make the changes that are needed to do normal password authentication. However, you may want to customize your configuration, in which case you must understand the configuration file.

PAM Modules

There are four types of modules defined by the PAM standard. These are:

<i>auth</i>	provides the actual authentication, perhaps asking for and checking a password, and they set “credentials” such as group membership
<i>account</i>	checks to make sure that the authentication is allowed (the account has not expired, the user is allowed to log in at this time of day, and so on)
<i>password</i>	used to set passwords
<i>session</i>	used once a user has been authenticated to allow them to use their account, perhaps mounting the user's home directory or making their mailbox available

These modules may be stacked, so that multiple modules are used. For instance, `rlogin` normally makes use of at least two authentication methods: if `rhosts` authentication succeeds, it is sufficient to allow the connection; if it fails, then standard password authentication is done.

New modules can be added at any time, and PAM-aware applications can then be made to use them.

Services

Each program using PAM defines its own “service” name. The **login** program defines the service type *login*, **ftpd** defines the service type *ftp*, and so on. In general, the service type is the name of the program used to access the service, not (if there is a difference) the program used to provide the service.

Role-Based Access Control

Role-Based Access Control for RedHawk Linux is implemented using PAM. In the Role-Based Access Control scheme, you set up a series of roles in the **capability.conf(5)** file. A role is defined as a set of valid Linux capabilities. The current set of all valid Linux capabilities can be found in the **/usr/include/linux/capability.h** kernel header file or by using the `_cap_names[]` string array. They are described in greater detail in Appendix C.

Roles can act as building blocks in that once you have defined a role, it can be used as one of the capabilities of a subsequent role. In this way the newly defined role inherits the capabilities of the previously defined role. Examples of this feature are given below. See the **capability.conf(5)** man page for more information.

Once you have defined a role, it can be assigned to a user or a group in the **capability.conf(5)** file. A user is a standard Linux user login name that corresponds to a valid user with a login on the current system. A group is a standard Linux group name that corresponds to a valid group defined on the current system.

Files in **/etc/pam.d** correspond to a service that a user can use to log into the system. These files need to be modified to include a **pam_capability** session line (examples of adding **pam_capability** session lines to service files are given in the “Examples” section below). For example: the **/etc/pam.d/login** file (**/etc/pam.d/remote** if it exists) is a good candidate as it covers login via telnet. If a user logs into the system using a service that has not been modified, no special capability assignment takes place.

NOTE: If capabilities are used, the **/etc/pam.d/su** file should be modified as a security precaution to ensure that an invocation such as **su -l nobody daemon** will impart to *daemon* only the capabilities listed for user **nobody**, and will not impart any extra capabilities from the invoking user.

The following options can be specified when supplying a **pam_capability** session line to a file in **/etc/pam.d**:

conf=conf_file	specify the location of the configuration file. If this option is not specified then the default location will be /etc/security/capability.conf .
debug	Log debug information via syslog . The debug information is logged in the syslog authpriv class. Generally, this log information is collected in the /var/log/secure file.

Examples

The following examples illustrate adding session lines to `/etc/pam.d/login`. Also make these changes to `/etc/pam.d/remote` if it exists.

NOTE: The path to the PAM files on i386 systems is `/lib/security`.

The path on x86_64 systems is `/lib64/security`.

1. To allow the roles defined in the `/etc/security/capability.conf` file to be assigned to users who login to the system via `telnet(1)` append the following line to `/etc/pam.d/login`:

```
session required /lib/security/pam_capability.so
```

2. To allow the roles defined in the `/etc/security/capability.conf` file to be assigned to users who login to the system via `ssh(1)` append the following line to `/etc/pam.d/sshd`:

```
session required /lib/security/pam_capability.so
```

3. To allow roles defined in the `/etc/security/capability.conf` file to be assigned to substituted users via `su(1)`, and to ensure that those substituted users do not inherit inappropriate capabilities from the invoker of `su(1)`, append the following line to `/etc/pam.d/su`:

```
session required /lib/security/pam_capability.so
```

4. To have `ssh` users get their role definitions from a different `capability.conf` file than the one located in `/etc/security` append the following lines to `/etc/pam.d/sshd`:

```
session required /lib/security/pam_capability.so \
conf=/root/ssh-capability.conf
```

Thus, the roles defined in the `/root/ssh-capability.conf` file will be applied to users logging in via `ssh`.

Defining Capabilities

The `capability.conf` file provides information about the roles that can be defined and assigned to users and groups. The file has three types of entries: Roles, Users and Groups.

Roles

A role is a defined set of valid Linux capabilities. The current set of all valid Linux capabilities can be found in the `/usr/include/linux/capability.h` kernel header file or by using the `_cap_names[]` string array described in the `cap_from_text(3)` man page. The capabilities are also described in full detail in Appendix C. In addition, the following capability keywords are pre-defined:

```

all          all capabilities (except cap_setcap)
cap_fs_mask all file system-related capabilities
none        no capabilities whatsoever

```

As the name implies, it is expected that different roles will be defined, based on the duties that various system users and groups need to perform.

The format of a role entry in the **capability.conf** file is:

```

role      rolename      capability_list

```

Entries in the capability list can reference previously defined roles. For example, you can define a role called *basic* in the file and then add this role as one of your capabilities in the capability list of a subsequent role. Note that the capability list is a whitespace or comma separated list of capabilities that will be turned on in the user's inheritable set.

Users

A user is a standard Linux user login name that corresponds to a valid user with a login on the current system. User entries that do not correspond to valid users on the current system (verified by **getpwnam(3)**) are ignored.

The format of a user entry in the **capability.conf** file is:

```

user      username      rolename

```

The special username '*' can be used to assign a default role for users that do not match any listed users or have membership in a listed group:

```

user      *              default_rolename

```

Groups

A group is a standard Linux group name that corresponds to a valid group defined on the current system. Group entries that do not correspond to valid groups on the current system (verified by **getgrnam(3)**) are ignored.

The format of a group entry in the **capability.conf** file is:

```

group    groupname      rolename

```

Examples

1. The following example sets up an administrative role (admin) that is roughly equivalent to root:

```

role      admin          all

```

2. The following example sets up a desktop user role that adds `sys_boot` and `sys_time` to the inheritable capability set:

```

role      desktopuser    cap_sys_boot \
                        cap_sys_time

```

3. The following example sets up a poweruser user role, using the desktop user role created previously:

```
role    poweruser    desktopuser\  
                        cap_sys_ptrace\  
                        cap_sys_nice\  
                        cap_net_admin
```

4. To assign the desktopuser role to a user, enter the following in the USERS section of the **capability.conf** file:

```
user    joe          desktopuser
```

5. To assign the poweruser role to a group, enter the following in the GROUPS section of the **capability.conf** file:

```
group   hackers      poweruser
```

Implementation Details

The following items address requirements for full implementation of the PAM functionality:

- **Pam_capability** requires that the running kernel be modified to inherit capabilities across the **exec()** system call. Kernels that have been patched with the kernel patch shipped with this module can enable capability inheritance using the **INHERIT_CAPS_ACROSS_EXEC** configuration option accessible under **General Setup** on the Kernel Configuration GUI (refer to the “Configuring and Building the Kernel” chapter of this guide). All RedHawk Linux kernels have this option enabled by default.
- In order to use the **pam_capability** feature with **ssh**, the **/etc/ssh/sshd_config** file must have the following option set:

```
UsePrivilegeSeparation no
```

This chapter addresses issues relating to user-level and kernel-level device drivers under RedHawk Linux. It includes information about added functionality that facilitates writing device drivers as well as real-time performance issues. Prior knowledge of how to write Linux-based device drivers is assumed. Userspace I/O (UIO) drivers are also described.

Information about RedHawk support for a PCI-to-VME bridge device can be found in Chapter 15, “PCI-to-VME Support.”

Understanding Device Driver Types

It is possible to write simple user-level device drivers under RedHawk Linux. A user-level driver can access I/O space to read and write device registers, thus initiating a programmed I/O operation. With the assistance of a skeletal kernel driver, a user-level driver can also initiate actions upon receipt of an interrupt. This is accomplished by supporting functions which allow a signal handler in the user-level driver to be attached to the interrupt routine. Refer to the section “Kernel Skeleton Driver” later in this chapter for the location of a sample kernel driver template for handling an interrupt and sending a signal to a user-level process.

It is not practical to write a user-level driver which does DMA I/O operations under Linux. There are several problems that prohibit DMA operations from user-level; for example, there is currently no supported method for determining the physical address of a user space buffer. Kernel-level device drivers should be used for devices that utilize DMA for I/O operations.

Userspace I/O (UIO) can be used to write user-level device drivers for any number of I/O boards. UIO requires a small per-device kernel module, with the main part of the driver written in user space, utilizing the tools and libraries commonly used for userspace applications. Refer to “Userspace I/O Drivers (UIO)” on page 14-15.

Developing User-level Device Drivers

The sections that follow describe particulars of the RedHawk Linux operating system that affect writing user-level device drivers.

Accessing PCI Resources

During the boot process, devices on the PCI bus are automatically configured, have their interrupts assigned and have their registers mapped into memory regions where the device registers can be accessed via memory-mapped I/O operations. These memory regions are known as base address registers (BARs). A device can have up to six BARs. The content of the BARs vary depending upon the device. Consult the device’s manual for this information.

RedHawk Linux supports a PCI resource file system located in `/proc/bus` that simplifies the code needed to map the registers of a PCI device. This file system provides BAR files representing memory regions that can be mapped into the address space of a program, providing access to the device without having to know the physical address associated with the device. The PCI BAR file system also provides a *config-space* file which can be used to read and write to the device's PCI config space. The first 64 bytes of the *config-space* file are defined by the PCI specification. The remaining 192 bytes are device vendor-specific.

Each PCI hardware device has associated with it a Vendor ID and Device ID. These are fixed values that do not change over time or between systems. Because of the dynamic configuration of PCI devices at boot time, the domain, bus, slot and function numbers remain fixed once the system is booted, but may vary between systems depending on the underlying hardware, even for boards that appear to be plugged into the same PCI bus slot in each system. Paths within the `/proc/bus/pci` and BAR file systems are derived from the domain, bus, slot and function numbers assigned by the kernel, and are affected by the physical hardware layout of the host system. Changes, such as physically plugging a board into a different slot, adding a device to the system or modifications to the system BIOS can change the bus and/or slot number assigned to a particular device.

The PCI BAR scan interfaces described below offer a method for finding the bar file associated with a particular device. Without these interfaces, the hardware-dependent nature of these BAR file paths makes the task of programming user-level device drivers somewhat inconvenient, because the driver has to locate the slot address of the appropriate device in order to obtain access to its BAR files.

Using the library interface for the BAR file system and the fixed vendor ID and device ID values, the other values currently associated with the PCI devices can be obtained. These include the BAR file directory path for the device as well as information about each BAR file in that directory. It also returns IDs for vendor, device, class, subclass, IRQ number (if assigned), and domain, bus, slot and function numbers related to each device.

This support is enabled by default in all RedHawk pre-built kernels through the `PROC_PCI_BARMAP` kernel parameter, which is located under **Bus options** on the Kernel Configuration GUI.

PCI BAR Interfaces

The sections that follow explain the PCI BAR interfaces.

The library scan functions are iterative. If the system has more than one instance of the desired device type, these library functions must be called multiple times. One function is provided that returns the count of all matching devices in the system. Other functions will iteratively return information for devices that match the search criteria. Device information is returned in the `bar_context` type defined in `/usr/include/pci_bar.h`. This structure is created with a call to `bar_scan_open`. Multiple scans can be active concurrently, each having a unique `bar_context`.

The interfaces are briefly described as follows:

<code>bar_scan_open</code>	starts a new scan of PCI devices
<code>bar_scan_next</code>	obtains the next matching PCI device
<code>bar_device_count</code>	returns the number of matching devices remaining in the active scan

bar_scan_rewind	restarts a scan
bar_scan_close	closes the active scan and frees associated memory
free_pci_device	frees all allocated memory associated with a located device
bar_mmap	mmap 's the BAR file with proper page alignment
bar_munmap	munmap 's the bar_mmap 'd BAR file

Note that to use these interfaces, you must link your application with the **libccur_rt** library:

```
gcc [options] file -lccur_rt ...
```

An example illustrating the use of these functions is provided as **/usr/share/doc/ccur/examples/pci_barscan.c**.

bar_scan_open(3)

This function is used to create the initial context for a search of PCI devices. The returned **bar_context** is an opaque pointer type defined in **/usr/include/pcibar.h** that designates state data for the iterator interfaces. Its value must be provided to subsequent calls to **bar_scan_next**, **bar_device_count**, **bar_scan_rewind** and **bar_scan_close**.

Synopsis

```
#include <linux/pci_ids.h>
#include <pcibar.h>

bar_context bar_scan_open(int vendor_id, int device_id);
```

Arguments are defined as follows:

<i>vendor_id</i>	a vendor identification value defined in /usr/include/linux/pci_ids.h . or the special value ANY_VENDOR . ANY_VENDOR matches all <i>vendor_id</i> values for all devices on the host system.
<i>device_id</i>	a device identification value defined in /usr/include/linux/pci_ids.h . or the special value ANY_DEVICE . ANY_DEVICE matches all <i>device_id</i> values for all devices on the host system.

Refer to the man page for error conditions.

bar_scan_next(3)

This function returns a pointer to a struct **pci_device** object for the next matching PCI device found.

Synopsis

```
#include <linux/pci_ids.h>
#include <pcibar.h>

struct pci_device * bar_scan_next(bar_context ctx);
```

The argument is defined as follows:

ctx an active `bar_context` returned by `bar_scan_open`.

When no further matching devices are available, this function returns `NIL_PCI_DEVICE` and sets *errno* to zero. Refer to the man page for error conditions.

bar_device_count(3)

This function returns the number of unprocessed devices remaining in an active scan. When called immediately after a call to `bar_scan_open` or `bar_scan_rewind`, this is the total number of matching devices for the specified *vendor_id* and *device_id*. This value is reduced by 1 upon each call to `bar_scan_next`.

Synopsis

```
#include <linux/pci_ids.h>
#include <pcibar.h>

int bar_device_count(bar_context ctx);
```

The argument is defined as follows:

ctx an active `bar_context` returned by `bar_scan_open`.

On success, this function returns a non-negative count of the number of unreported devices that would be returned by subsequent calls to `bar_scan_next`. Refer to the man page for error conditions.

bar_scan_rewind(3)

This function resets the specified `bar_context` to the state it was in immediately after the initial call to `bar_scan_open`.

Synopsis

```
#include <linux/pci_ids.h>
#include <pcibar.h>

void bar_scan_rewind(bar_context ctx);
```

The argument is defined as follows:

ctx an active `bar_context` returned by `bar_scan_open`. If the value is `NIL_BAR_CONTEXT` or does not designate a valid `bar_context` object, this call has no effect.

bar_scan_close(3)

This function frees all allocated memory associated with the designated `bar_context`. The value `NIL_BAR_CONTEXT` is assigned to the `bar_context` object and may no longer be used after this call.

Synopsis

```
#include <linux/pci_ids.h>
#include <pcibar.h>

void bar_scan_close(bar_context ctx);
```

The argument is defined as follows:

ctx an active `bar_context` returned by `bar_scan_open`.

`free_pci_device(3)`

This function releases all allocated memory associated with the designated `struct pci_device` object.

Synopsis

```
#include <linux/pci_ids.h>
#include <pcibar.h>

void free_pci_device(struct pci_device * dev);
```

The argument is defined as follows:

dev a valid `struct pci_device` obtained from `bar_scan_next`.

`bar_mmap(3)`

This function can be used to map the specified BAR file into memory. It is a wrapper around `mmap(2)` that aligns small BAR files at the start of the mmap'ed BAR data rather than the beginning of the area that is mmap'ed. Use `bar_munmap(3)` to unmap files mapped using this function.

Synopsis

```
#include <linux/pci_ids.h>
#include <pcibar.h>

void * bar_mmap(char * barfilepath, void * start, size_t length, int
prot, int flags, int fd, off_t offset);
```

The arguments are defined as follows:

barfilepath the path of the BAR file to be mmap'ed

Refer to `mmap(2)` for a description of the other parameters.

`bar_munmap(3)`

This function must be used to unmap files that are mapped using `bar_mmap(3)`.

Synopsis

```
#include <linux/pci_ids.h>
#include <pcibar.h>

int bar_munmap(void * start, size_t length);
```

Refer to `munmap(2)` for a description of the parameters.

Kernel Skeleton Driver

When a device issues interrupts that must be handled by the device driver, it is not possible to build the device driver completely at user level because Linux has no method for attaching a user-level routine to an interrupt. It is however possible to build a simple kernel device driver that handles the device interrupt and issues a signal to the user-level application that is running a user-level driver. Because signals are delivered asynchronously to the execution of a program and because signals can be blocked during critical sections of code – a signal acts much like a user-level interrupt.

The following example of a skeletal kernel-level driver shows how to attach a signal to the occurrence of a device interrupt and the code for the interrupt service routine which will then trigger the signal. The full code for this skeletal driver can be found on a RedHawk installed system in the directory `/usr/share/doc/ccur/examples/driver`. You can use the sample driver, `sample_mod`, as a template for writing a simple kernel-level driver that handles an interrupt and sends a signal to a user-level process.

Understanding the Sample Driver Functionality

The sample driver uses real time clock (rtc) 0 as the hardware device that will generate the interrupts. Rtc 0 is one of the real-time clocks on Concurrent's Real-Time Clock and Interrupt Module (RCIM). The clock counts down to 0 at a predefined resolution and then starts over. Each time the count reaches 0, an interrupt is generated. Some of the setup for real time clock 0 is performed in the module's "init" routine where the device registers are mapped into memory space so that the driver may access those registers. The last section of code shown for the module's "init" routine is the code that attaches the interrupt routine to an interrupt vector.

```

*****
int sample_mod_init_module(void)
{
...
// find rcim board (look for RCIM II, RCIM I, and finally RCIM I old rev)
dev = pci_find_device(PCI_VENDOR_ID_CONCURRENT, PCI_DEVICE_ID_RCIM_II, dev);
if (dev == NULL) {
    //try another id
    dev = pci_find_device(PCI_VENDOR_ID_CONCURRENT_OLD, PCI_DEVICE_ID_RCIM, dev);
}
if (dev == NULL) {
    //try another id
    dev = pci_find_device(PCI_VENDOR_ID_CONCURRENT_OLD, PCI_DEVICE_ID_RCIM_OLD, dev);
}
if (dev == NULL) {
    //no rcim board, just clean up and exit
    unregister_chrdev(major_num, "sample_mod");
    return -ENODEV;
}

...

if ((bd_regs = ioremap_nocache(plx_mem_base, plx_mem_size)) == NULL)
    return -ENOMEM;

...

if ((bd_rcim_regs = ioremap_nocache(rcim_mem_base, rcim_mem_size)) == NULL)
    return -ENOMEM;

...

sample_mod_irq = dev->irq;
res = request_irq(sample_mod_irq, rcim_intr, SA_SHIRQ, "sample_mod", &rtc_info);

```

The complete initialization of the rtc 0 device is performed in the module's "open" method. For this example, the device is automatically set up so that interrupts will be generated by the device. When the device is opened, interrupts associated with rtc 0 are enabled, the device is programmed to count from 10000 to 0 with a resolution of 1 microsecond, and the clock starts counting. It generates an interrupt when the count reaches 0.

```
*****
int rcim_rtc_open(struct inode *inode, struct file *filep)
{
    u_int32_t val;

    if (rtc_info.nopens > 0) {
        printk(KERN_ERR "You can only open the device once.\n");
        return -ENXIO;
    }
    rtc_info.nopens++;
    if (!rtc_info.flag)
        return -ENXIO;
    writel(0, &bd_rcim_regs->request);
    writel(ALL_INT_MASK, &bd_rcim_regs->clear);
    writel(RCIM_REG_RTC0, &bd_rcim_regs->arm);
    writel(RCIM_REG_RTC0, &bd_rcim_regs->enable);
    writel(RTC_TESTVAL, &bd_rcim_regs->rtc0_timer); //rtc data reg
    val = RCIM_RTC_1MICRO | RCIM_RTC_START | RCIM_RTC_REPEAT;
    writel(val, &bd_rcim_regs->rtc0_control);
    return 0;
}
*****
```

The user-level driver must specify which signal should be sent when the kernel-level driver receives an interrupt. The user-level driver makes an `ioctl()` call, which is handled by the kernel-level driver's `ioctl` method. When the user-level driver calls this `ioctl()` function, it indicates to the kernel-level driver that the user-level process has already set up a signal handler for the specified signal and the user-level driver is now ready to receive a signal.

The calling user-space process specifies the signal number it wishes to receive from the module. The driver remembers the process ID associated with the requested signal number by using the "current" structure. The "signal/process id" pair is stored in the module's `rtc_info` structure and will later be used by the "notification" mechanism described below.

```
*****
int rcim_rtc_ioctl(struct inode *inode, struct file *filep, unsigned int cmd,
unsigned long arg)
{
    if (!rtc_info.flag)
        return (-ENXIO);

    switch (cmd)
    {
        // Attach signal to the specified rtc interrupt
        case RCIM_ATTACH_SIGNAL:
            rtc_info.signal_num = (int)arg;
            rtc_info.signal_pid = current->tgid;
            break;

        default:
            return (-EINVAL);
    }
    return (0);
}
*****
```

The actual notification is implemented in the module's interrupt handler. When an interrupt is received from rtc 0, this interrupt service routine determines whether to send a signal to a process that has requested it. If there is a registered "process id/signal number" pair in the `rtc_info` structure, the specified signal is sent to the corresponding process using the function `kill_proc()`.

```

*****
int rcim_intr(int irq, void *dev_id, struct pt_regs *regs)
{
    u_int32_t isr;

    isr = readl(&bd_rcim_regs->request);
    writel(0, &bd_rcim_regs->request);
    writel(ALL_INT_MASK, &bd_rcim_regs->clear);

    /* Use isr to determine whether the interrupt was generated by rtc 0 only if
    "rcim" module is not built into the kernel. If "rcim" is active, its
    interrupt handler would have cleared "request" register by the time we
    get here. */

    // if (isr & RCIM_REG_RTC0) {
        // Send signal to user process if requested
        if (rtc_info.signal_num && rtc_info.signal_pid &&
            (kill_proc(rtc_info.signal_pid, rtc_info.signal_num, 1) == -ESRCH))
        {
            rtc_info.signal_pid = 0;
        }
    // }

    return IRQ_HANDLED;
}
*****

```

When the device is closed, rtc 0 is shut down. The count value is reset to 0 and the clock is stopped. The interrupt/signal attachment is cleared so that no further signal will be sent if further interrupts are received.

```

*****
int rcim_rtc_close(struct inode *inode, struct file *filep)
{
    if (!rtc_info.flag)
        return (-ENXIO);
    rtc_info.nopens--;
    if (rtc_info.nopens == 0) {
        writel(~RCIM_RTC_START, &bd_rcim_regs->rtc0_control);
        writel(0, &bd_rcim_regs->rtc0_timer);
        rtc_info.signal_num = 0;
        rtc_info.signal_pid = 0;
    }
    return 0;
}
*****

```

Testing the Driver

The best way to test the sample kernel module is to build the kernel without the RCIM driver and then load the sample driver. However, this module is designed to work with or without the RCIM driver already built into the kernel.

The RCIM kernel module and the sample kernel module share the same interrupt line. When an interrupt occurs, RCIM's interrupt handler is invoked first and the hardware interrupt register on the RCIM board is cleared. Then the sample module's interrupt handler is invoked.

If both modules are loaded, the second handler will find the interrupt register cleared and if a check for "interrupt source" is performed, the handler will assume that the interrupt came from a device different from rtc 0. To overcome this obstacle, the following line in the sample module's interrupt handler has been commented out when both RCIM and the sample module are loaded:

```
//      if (isr & RCIM_REG_RTC0) { .
```

The code that follows is a simple user-level program which demonstrates how a user-level driver would attach a routine such that this routine is called whenever the RCIM skeletal driver's interrupt fires. The routine "interrupt_handler" is the routine which is called when the RCIM's rtc 0 interrupt fires. This program is terminated by typing Ctrl-C at the terminal where the program is run. Note that this sample code is also available in `/usr/share/doc/ccur/examples/driver/usersample`.

In order to load the sample module and successfully run the user sample program, all applications that use the RCIM driver should be aborted.

Below is the `usersample` program.

```
#include <stdio.h>
#include <fcntl.h>
#include <signal.h>
#include <errno.h>

#include "sample_mod.h"

static const char *devname = "/dev/sample_mod";
static int nr_interrupts = 0;
static int quit = 0;

void interrupt_handler (int signum)
{
    nr_interrupts++;

    if ((nr_interrupts % 100) == 0) {
        printf (".");
        fflush(stdout);
    }
    if ((nr_interrupts % 1000) == 0)
        printf (" %d interrupts\n", nr_interrupts);
}

void ctrl_c_handler (int signum)
{
    quit++;
}

int main()
{
    int fd;
    struct sigaction intr_sig = { .sa_handler = interrupt_handler };
    struct sigaction ctrl_c_sig = { .sa_handler = ctrl_c_handler };

    sigaction (SIGUSR1, &intr_sig, NULL);
    sigaction (SIGINT, &ctrl_c_sig, NULL);

    if ((fd = open (devname, O_RDWR)) == -1) {
        perror ("open");
        exit(1);
    }

    if (ioctl (fd, RCIM_ATTACH_SIGNAL, SIGUSR1) == -1) {
        perror ("ioctl");
        exit(1);
    }

    printf ("waiting for signals...\n");
    while (! quit)
        pause();

    printf ("\nhandled %d interrupts\n", nr_interrupts);
    close(fd);
    exit(0);
}
```

Developing Kernel-level Device Drivers

The sections that follow describe particulars of the RedHawk Linux operating system that affect writing and testing kernel-level device drivers.

Building Driver Modules

Instructions for building driver modules for use with either a pre-existing RedHawk kernel or a custom kernel are provided in Chapter 11, *Configuring and Building the Kernel*.

Kernel Virtual Address Space

There are some cases when the amount of kernel virtual address space reserved for dynamic mappings of the kernel support routines `vmalloc()` and `ioremap()` is not enough to accommodate the requirements of a device. The default value, 128 MB, is enough for all systems except those with I/O boards that have very large onboard memories which are to be `ioremap`'ed. An example is the VMIC reflective memory board installed on an iHawk system when it is populated with 128 MB of memory.

When 128 MB of reserved kernel virtual address space is not enough, this value can be increased via the `VMALLOC_RESERVE` tunable, which is located under **General Setup** on the Kernel Configuration GUI.

Real-Time Performance Issues

A kernel-level device driver runs in kernel mode and is an extension of the kernel itself. Device drivers therefore have the ability to influence the real-time performance of the system in the same way that any kernel code can affect real-time performance. The sections that follow provide a high-level overview of some of the issues related to device drivers and real-time.

It should be noted that while there are many open source device drivers that are available for Linux, these drivers have a wide range of quality associated with them, especially in regards to their suitability for a real-time system.

Interrupt Routines

The duration of an interrupt routine is very important in a real-time system because an interrupt routine cannot be preempted to execute a high-priority task. Lengthy interrupt routines directly affect the process dispatch latency of the processes running on the CPU to which the interrupt is assigned. The term *process dispatch latency* denotes the time that elapses from the occurrence of an external event, which is signified by an interrupt, until the process waiting for that external event executes its first instruction in user mode. For more information on how interrupts affect process dispatch latency, see the “Real-Time Performance” chapter.

If you are using a device driver in a real-time production environment, you should minimize the amount of work performed at interrupt level. RedHawk Linux supports several different mechanisms for deferring processing that should not be performed at interrupt level. These mechanisms allow an interrupt routine to trigger processing that will be performed in the context of a kernel daemon at program level. Because the priority of these kernel daemons is configurable, it is possible to run high-priority real-time processes at a priority level higher than the deferred interrupt processing. This allows a real-time process to have higher priority than some activity that might normally be run at interrupt level. Using this mechanism, the execution of real-time tasks is not delayed by any deferred interrupt activity. See the “Deferred Interrupt Functions (Bottom Halves)” section for more information about deferring interrupts.

Generally, a device's interrupt routine can interact with the device to perform the following types of tasks:

- acknowledge the interrupt
- save data received from the device for subsequent transfer to a user
- initiate a device operation that was waiting for completion of the previous operation

A device's interrupt routine should *not* perform the following types of tasks:

- copy data from one internal buffer to another
- allocate or replenish internal buffers for the device
- replenish other resources used by the device

These types of tasks should be performed at program level via one of the deferred interrupt mechanisms. You can, for example, design a device driver so that buffers for the device are allocated at program level and maintained on a free list that is internal to the driver. When a process performs read or write operations, the driver checks the free list to determine whether or not the number of buffers available is sufficient for incoming interrupt traffic. The interrupt routine can thus avoid making calls to kernel buffer allocation routines, which are very expensive in terms of execution time. Should a device run out of resources and only notice this at interrupt level, new resources should be allocated as part of the deferred interrupt routine rather than at interrupt level.

Deferred Interrupt Functions (Bottom Halves)

Linux supports several methods by which the execution of a function can be deferred. Instead of invoking the function directly, a “trigger” is set that causes the function to be invoked at a later time. These mechanisms, called bottom halves, are used by interrupt routines under Linux in order to defer processing that would otherwise have been done at interrupt level. By removing this processing from interrupt level, the system can achieve better interrupt response time as described above.

There are three choices for deferring interrupts: softirqs, tasklets and work queues. Tasklets are built on softirqs and therefore they are similar in how they operate. Work queues operate differently and are built on kernel threads. The decision over which bottom half to use is important. Table 14-1 summarizes the types, which are explained at length in the sections below.

Table 14-1 Types of Bottom Halves

Bottom Half Type	Context	Serialization
Softirq	Interrupt	None
Tasklet	Interrupt	Against the same tasklet
Work queues	Process	None (scheduled as process context)

Softirqs and Tasklets

Two mechanisms for deferring interrupt processing have different requirements in terms of whether or not the code that is deferred must be reentrant or not. These types of deferrable functions are softirqs and tasklets. A *softirq* must be completely reentrant because a single instance of a softirq can execute on multiple CPUs at the same time. *Tasklets* are implemented as a special type of softirq. The difference is that a given tasklet function will always be serialized with respect to itself. In other words, no two CPUs will ever execute the same tasklet code at the same time. This property allows a simpler coding style in a device driver, since the code in a tasklet does not have to be reentrant with respect to itself.

In standard Linux, softirqs and tasklets are usually executed from interrupt context immediately after interrupt handlers transition from interrupt to program level. Occasionally, standard Linux will defer softirq and tasklets to a kernel daemon. Both methods allow softirqs and tasklets to execute with interrupts enabled; however, because they are usually executed from interrupt context, softirqs and tasklets cannot sleep.

RedHawk has been enhanced with an option (that is on by default) to guarantee that softirqs and tasklets are only executed in the context of a kernel daemon. The priority and scheduling policy of these kernel daemons can be set via kernel configuration parameters. This allows the system to be configured such that a high-priority real-time task can preempt the activity of deferred interrupt functions.

Softirqs and tasklets are both run by the **ksoftirqd** daemon. There is one **ksoftirqd** daemon per logical CPU. A softirq or tasklet will run on the CPU that triggered its execution. Therefore, if a hard interrupt has its affinity set to a specific CPU, the corresponding softirq or tasklet will also run on that CPU. The priority of the **ksoftirqd** is determined by the `SOFTIRQ_PRI` and `SOFTIRQ_PREEMPT_BLOCK` kernel tunables, which are located under **General Setup** on the Kernel Configuration GUI. When `SOFTIRQ_PRI` is set to a positive number, that number is the priority at which **ksoftirqd** will run. By default, this tunable is set to zero, and the setting of `SOFTIRQ_PREEMPT_BLOCK` affects the daemon's priority. When set to `Y`, the **ksoftirqd** daemon will run as under the `SCHED_FIFO` scheduling policy at a priority of one less than the highest real-time priority. When set to `N`, the **ksoftirqd** daemon will run at priority zero.

Work Queues

Work queues are another deferred execution mechanism. Unlike softirqs and tasklets, standard Linux always processes work queues in the process context of kernel daemons and therefore the code in a work queue is allowed to sleep.

The kernel daemons that process work queues are called worker threads. Worker threads are always created as a gang of threads, one per CPU, with each thread bound to a single CPU. Work on the work queue is maintained per CPU and is processed by the worker thread on that CPU.

The kernel provides a default work queue that drivers may use. The worker threads that process the default work queue are called **events/cpu**, where *cpu* is the CPU that the thread is bound to.

Optionally, drivers may create private work queues and worker threads. This is advantageous to the driver if the queued work is processor-intensive or performance critical. It also lightens the load on the default worker threads and prevents starving the rest of the work on the default work queue.

Worker threads execute on a CPU when work is placed on the work queue. Therefore, if a hard interrupt has its affinity set to a specific CPU, and the interrupt handler queues work, the corresponding worker thread will also run on that CPU. Worker threads are always created with a nice value of -10 but their priority may be modified with the **run(1)** command.

Understanding Priorities

When configuring a system where real-time processes can run at a higher priority than the deferred interrupt daemons, it is important to understand whether those real-time processes depend upon the services offered by the daemon. If a high-priority real-time task is CPU bound at a level higher than a deferred interrupt daemon, it is possible to starve the daemon so it is not receiving any CPU execution time. If the real-time process also depends upon the deferred interrupt daemon, a deadlock can result.

Multi-threading Issues

RedHawk Linux is built to support multiple CPUs in a single system. This means that all kernel code and device drivers must be written to protect their data structures from being modified simultaneously on more than one CPU. The process of multi-threading a device driver involves protecting accesses to data structures so that all modifications to them are serialized. In general this is accomplished in Linux by using spin locks to protect these kinds of data structure accesses.

Locking a spin lock will cause preemption and/or interrupts to be disabled. In either case, the worst case process dispatch latency for a process executing on the CPU where these features are disabled is directly impacted by how long they are disabled. It is therefore important when writing a device driver to minimize the length of time that spin locks are held, which will affect the amount of time that preemption and/or interrupts are disabled. Remember that locking a spin lock will implicitly cause preemption or interrupts to be disabled (depending upon which spin lock interface is used). For more information about this topic, see the “Real-Time Performance” chapter.

The Big Kernel Lock (BKL) and ioctl

The Big Kernel Lock (BKL) is a spin lock in the Linux kernel, which is used when a piece of kernel source code has not been fine-grain multi-threaded. While much use of the BKL has been removed by systematically multi-threading the Linux kernel, the BKL is still the most highly contended and longest held lock in the Linux kernel.

By default, the Linux kernel will lock the BKL before calling the **ioctl(2)** function associated with a device driver. If a device driver is multi-threaded, then it is not necessary to lock the BKL before calling **ioctl**. RedHawk Linux allows a device driver to specify that the BKL should not be locked before calling **ioctl**. When a device is used to support real-time functions or when an application makes calls to a device's **ioctl**

routine on a shielded CPU, it is very important that the device driver be modified so the BKL is not locked. Otherwise, a process could stall spinning on the BKL spin lock for an extended period of time causing jitter to the programs and interrupts that are assigned to the same CPU.

The mechanism for specifying that the BKL should not be locked on entry to a device's `ioctl` routine is to set the `FOPS_IOCTL_NOBKL` flag in the `file_operations` structure in the device driver source code. Below is an example of how the RCIM device sets this flag:

```
static struct file_operations rcim_fops = {
    owner:          THIS_MODULE,
    open:           rcim_master_open,
    release:        rcim_master_release,
    ioctl:          rcim_master_ioctl,
    mmap:           rcim_master_mmap,
    flags:          FOPS_IOCTL_NOBKL,
};
```

After making this change, the device driver must be rebuilt. For a static driver this means rebuilding the entire kernel. For a dynamically loadable module, only that module must be rebuilt. See the “Configuring and Building the Kernel” chapter for more information.

Userspace I/O Drivers (UIO)

UIO is a standardized method for writing user level drivers. This still requires a small per-driver kernel module; however, the main part of the driver is written in user space, using the tools and libraries you are familiar with.

Using UIO, you can take any standard PCI card and make a simple userspace driver for any desired purpose. These drivers are easy to implement and test and they are isolated from kernel version changes. Bugs in your driver won't crash the kernel and updates of your driver can take place without recompiling the kernel.

Currently, UIO drivers can be used for char device drivers only and cannot be used to set up DMA operations from user space.

The small per-driver kernel module is required to:

- match the device ID and vendor ID of the board
- perform low-level initializations
- acknowledge interrupts

Once you have a working kernel module for your hardware, you can write the userspace driver using any of the tools and libraries normally used for writing user applications. The `lsuio(1)` tool can be used to list UIO devices and their attributes.

Each UIO device is accessed through a device file: `/dev/uio0`, `/dev/uio1`, and so on. Driver attributes used to read or write variables appear under the `/sys/class/uio/uioX` directory. Memory regions are accessed via `mmap(1)`.

Complete instructions for writing UIO device drivers can be found at `/usr/share/doc/ccur/examples/driver/uio/uio-howto.pdf` and are beyond the scope of this chapter.

Example UIO kernel and user drivers for both Concurrent's RCIM board and a PMC-16AIO board are supplied at `/usr/share/doc/ccur/examples/driver/uio`. Both contain comments explaining what functions the drivers perform.

RedHawk has UIO support enabled by default in its pre-built kernels through the UIO kernel tunable, which is located under `Userspace I/O` on the Kernel Configuration GUI.

Analyzing Performance

NightTrace RT, a graphical analysis tool supplied by Concurrent, allows you to graphically display information about important events in your application and in the kernel, and can be used for identifying patterns and anomalies in your application's behavior. The ability to interactively analyze the code under varying conditions is invaluable toward fine-tuning the real-time performance of your device driver.

The process of supplying trace points in user-level code, capturing trace data and displaying the results is fully described in the *NightTrace RT User's Guide*, publication number 0890398. User and kernel trace events can be logged and displayed for analysis.

Kernel tracing utilizes pre-defined kernel trace events included in the trace and debug kernels. User-defined events can be logged using the pre-defined CUSTOM trace event or created dynamically. All are displayed by NightTrace RT for analysis. Refer to Appendix D for details about kernel trace events.

This chapter describes RedHawk Linux support for a PCI-to-VMEbus bridge.

Overview

A PCI-to-VMEbus adapter can be used to connect the iHawk PCI-based system with a VMEbus system. This allows transparent access to all VME memory space and interrupt levels to control and respond to the VME card as though it were plugged directly into the iHawk PCI backplane.

RedHawk Linux includes support for the Model 618-3 and Model 620-3 PCI-to-VMEbus adapters from SBS Technologies. Using the adapter, memory is shared between the two systems. Two methods are utilized: memory mapping and Direct Memory Access (DMA). Memory mapping supports bi-directional random access bus mastering from either system. This allows programmed I/O access to VMEbus RAM, dual-port memory and VMEbus I/O. On each system, a bus master can access memory in the other system from a window in its own address space. Mapping registers allow PCI devices to access up to 32 MB of VMEbus address space and VMEbus devices to access up to 16 MB of PCI space.

Two DMA techniques are supported: Controller Mode DMA and Slave Mode DMA. Controller mode DMA provides high-speed data transfers from one system's memory directly into the other system's memory. Data transfers can be initiated in both directions by either processor at rates up to 35 MB per second and up to 16 MB per transfer.

VMEbus devices that have their own DMA controllers can use Slave Mode DMA instead of Controller Mode DMA. This allows a VMEbus DMA device to transfer data directly into PCI memory at data rates in excess of 15 MB per second.

The adapter consists of three parts: the PCI adapter card, the VMEbus adapter card and a fiber optic cable.

The PCI adapter card self-configures at boot time. It responds to and generates A32 memory and I/O accesses and supports D32, D16 and D8 data widths.

The VMEbus adapter card is configured via jumpers. The VMEbus adapter card responds to and generates A32, A24, and A16 accesses and supports D32, D16, and D8 data widths.

Software support for the adapter includes the SBS Linux Model 1003 PCI Adapter Support Software Version 2.2, with modifications for execution and optimization under RedHawk Linux. The software includes a device driver that can access dual-port and/or remote memory space from an application, and example programs to help applications programmers with adapter and system configuration.

Documentation

This chapter provides the information you will need to configure and use this support under RedHawk Linux.

For information beyond the scope of this chapter, refer to the following documents that are included with the RedHawk Linux documentation:

- *SBS Technologies Model 618-3, 618-9U & 620-3 Adapters Hardware Manual (sbs_hardware.pdf)*
- *SBS Technologies 946 Solaris, 965 IRIX 6.5, 983 Windows NT/2000, 993 VxWorks & 1003 Linux Support Software Manual (sbs_software.pdf)*

Installing the Hardware

The adapter consists of three parts: the PCI adapter card, the VMEbus adapter card and a fiber optic cable. Instructions for installing these are given below.

Normally, installation and configuration of the hardware is done by Concurrent Computer Corporation. This information is provided for those cases where a PCI-to-VME bridge is added to a system in a post-manufacturing environment.

Unpacking

When unpacking the equipment from the shipping container, refer to the packing list and verify that all items are present. Save the packing material for storing and reshipping the equipment.

NOTE

If the shipping container is damaged upon receipt, request that the carrier's agent be present during unpacking and inspection of the equipment.

Before attempting to install the cards in your system, read the following:

CAUTION

Avoid touching areas of integrated circuitry as static discharge can damage circuits.

It is strongly recommended that you use an antistatic wrist strap and a conductive foam pad when installing and removing printed circuit boards.

Configuring the Adapter Cards

There are no jumpers to configure on the PCI adapter card.

VME adapter card jumper configuration should take place before the VME adapter card is installed, or when the current settings of the VMEbus attributes that are controlled by the VME adapter card jumpers need to be changed.

Refer to Chapter 10 of the SBS Technologies Hardware Manual for information about configuring the VMEbus adapter card. The following additional information may prove useful:

- The System Jumpers must be set appropriately, based on whether this VME adapter card is used as the system controller in slot 1, or as a non-system controller in some other VME slot.
- To make use of the `bt_bind()` buffer support or the local memory device support (`BT_DEV_LM`) that lets devices on the VMEbus access memory on the iHawk system through VME slave windows, the Remote REM-RAM HI and LO jumpers must be set up to indicate the VMEbus base address and range of the VME slave windows out on the VMEbus.

The base address should be placed on a 16 MB boundary, and the size of this area should typically be set to (but not exceed) 16 MB in order to make use of the total amount of area supported by the SBS hardware; for example, to set up an A32 address range of 0xC0000000 to 0xC1000000, the jumpers should be configured to the settings below:

To set an A32 address range, the jumpers at the bottom of the REM-RAM should be set to:

A32 jumper IN
A24 jumper OUT

To specify a starting address of 0xC0000000, the row of LO address REM-RAM jumpers should be set to:

31 and 30 jumpers OUT
All other LO jumpers IN (29 through 16)

To specify an ending address of 0xC1000000, the row of HI address REM-RAM jumpers should be set to:

31, 30 and 24 jumpers OUT
All other HI jumpers IN (29-25, and 23-16)

Installing the PCI Adapter Card

Use the following procedure to install the PCI adapter in your iHawk system:

1. Ensure that the iHawk system is powered down.
2. Locate a vacant PCI card slot in the chassis that supports a bus master.
3. Remove the metal plate that covers the cable exit at the rear of the chassis.
4. Insert the PCI adapter card into the connector.
5. Fasten the adapter card in place with the mounting screw.
6. Replace the cover.

Installing the VMEbus Adapter Card

NOTE

VMEbus backplanes have jumpers to connect the daisy-chained, bus grant and interrupt acknowledge signals around unused card locations. Make sure these jumpers are removed from the slot in which the adapter card will be installed.

1. Ensure that the VMEbus chassis is powered down.
2. Decide whether the VMEbus adapter card is the system controller. If the VMEbus adapter card is the system controller, it must be installed in slot 1.

If the adapter card is not the system controller, locate an unoccupied 6U slot in the VMEbus card cage for the adapter.
3. Insert the card into the connector of the selected slot.

Connecting the Adapter Cable

NOTE

Keep the ends of the fiber-optic cable clean. Use alcohol-based fiber-optic wipes to remove minor contaminants such as dust and dirt.

Fiber-optic cables are made of glass: therefore, they may break if crushed or bent in a loop with less than a 2-inch radius.

1. Ensure that the iHawk computer system and the VMEbus chassis are powered off.
2. Remove the rubber boots on the fiber-optic transceivers as well as the ones on the fiber-optic cables. Be sure to replace these boots when cables are not in use.

3. Plug one end of the fiber-optic cable into the PCI adapter card's transceiver.
4. Plug the other end of the fiber-optic cable into the VMEbus adapter card's transceiver.
5. Turn power on to both PCI and VMEbus systems.
6. Ensure that the READY LEDs on both adapter cards are lit. They must be on for the adapter to operate.

Installing the Software

The software is contained on an optional product CD delivered with RedHawk Linux. It is installed using the **install-sbsvme** installation script.

To install the software, perform the following steps:

1. With RedHawk Linux Version 2.1 or later running on the iHawk system, log in as root and take the system down to single-user mode:
 - a. Right click on the desktop and select **New Terminal**.
 - b. At the system prompt, type **init 1**.
2. Locate the disc labeled "RedHawk Linux PCI-to-VME Bridge Software Library" and insert it into the CD-ROM drive.
3. To mount the cdrom device, execute the following command:

NOTE: **/media/cdrom** is used in the examples that follow. Depending on the type of drive attached to your system, the actual mount point may differ. Check **/etc/fstab** for the correct mount point.

```
mount /media/cdrom
```

4. To install, execute the following commands:

```
cd /media/cdrom  
./install-sbsvme
```

Follow the on-screen instructions until the installation script completes.

5. When the installation completes, execute the following commands:

```
cd /  
umount /media/cdrom  
eject
```

6. Remove the disc from the CD-ROM drive and store. Exit single-user mode (Ctrl-D).

Configuration

The sections below discuss configuration of the module under RedHawk Linux and other attributes that can be established at system initialization.

The btp Module

The pre-defined RedHawk kernels have the SBS Technologies PCI-to-VMEbus bridge configured as a module by default. This can be disabled if desired through the SBSVME option under the Device Drivers -> SBS VMEbus-to-PCI Support subsection on the Kernel Configuration GUI. The module is called "btp."

Device Files and Module Parameter Specifications

The `/dev/btp*` device files are created at initialization via `/etc/init.d/sbsvme`. The attributes for those files are defined in `/etc/sysconfig/sbsvme`. In addition, the following module parameter specifications can be made in this file. The default is no parameters.

`btp_major=num` Specifies the major device number (*num*). By default, it is 0 (zero) which allows the kernel to make the selection. If you supply a nonzero device number, it must not already be in use. The `/proc/devices` file can be examined to determine which devices are currently in use.

`icbr_q_size=size` Specifies the number of ICBR entries (*size*) to be allocated for the interrupt queue. Once set, this value cannot be changed without unloading and reloading the btp driver. The default value is 1 KB of interrupt queue space.

`lm_size=size1, size2, ...` Specifies an array of local memory (BT_DEV_LM) sizes in bytes with one for each SBS PCI-to-VME controller (unit) present in the system. If this value is set to 0 (zero), local memory is disabled for that specific unit only. The default value is 64 KB of local memory and the maximum value is 4 MB. Refer to the "Local Memory" section of this chapter for more information.

`trace=flag_bits` Specifies the device driver tracing level. This is used to control which trace messages the btp driver displays. The possible bits to use are the `BT_TRC_XXX` values located in `/usr/include/btp/btngpci.h`. Because tracing has an impact on performance, this feature should be used only for debugging btp driver problems. The default value is 0 (zero) for no trace messages.

The following are examples of btp module parameter specifications:

```
BTP_MOD_PARAMS='bt_major=200 trace=0xff lm_size=0'  
BTP_MOD_PARAMS='icbr_q_size=0x1000 lm_size=0x8000,0x4000'
```

VMEbus Mappings

Support for automatically creating and removing PCI-to-VMEbus mappings is included in the `/etc/init.d/sbsvme` initialization script. When mappings are defined in `/etc/sysconfig/sbsvme-mappings`, they are created during “`/etc/init.d/sbsvme start`” processing and removed during the “`stop`” processing.

The `/etc/sysconfig/sbsvme-mappings` file contains help information and commented-out templates for creating VMEbus mappings. The template examples can be used to create customized VMEbus mappings, if desired. The mappings are created by writing values to the `/proc/driver/btp/unit/vme-mappings` file, which is explained as comments within the `sbsvme-mappings` file and in the section “The `/proc` File System Interface” later in this chapter.

By making use of the `sbsvme-mappings` file to create PCI-to-VMEbus mappings during system initialization, you may place additional lines in the `/etc/rc.d/rc.local` script to invoke `shmconfig(1)` to create globally-visible shared memory areas that are bound to VMEbus space. A sample script is provided that illustrates this. Refer to the “Example Applications” section for details.

User Interface

Some modifications to the standard support software have been made for RedHawk Linux. In addition to installation modifications, the following have been added:

- Support for binding multiple buffers of various sizes. In a system with multiple user-level device drivers, this capability allows each driver to allocate its own bind buffer instead of having to share a single bind buffer between multiple devices. This capability also means that by allocating multiple large bind buffers, the total 16 MB area of hardware-supported VMEbus slave window space may be utilized. See the “Bind Buffer Implementation” section for more information. Example programs have been added that demonstrate how to allocate and bind multiple buffers to VMEbus space (see the “Example Applications” section).
- Support for creating and removing VMEbus space mappings that are not associated with a specific process, and obtaining the starting PCI bus address location of that mapping to allow shared memory binding. This can be accomplished in one of two ways:
 - using the `bt_hw_map_vme/bt_hw_unmap_vme` library functions
 - writing to the `/proc/driver/btp` file system

See the “Mapping and Binding to VMEbus Space” section for more details. Example programs demonstrate how to create, display and remove VMEbus mappings using both methods (see the “Example Applications” section).

API Functions

Table 15-1 lists the API functions included in the `libbt` library. The functions that have been modified or added are noted and described in the sections that follow. The remaining functions are described in the SBS Technologies Software Manual included with the RedHawk Linux documentation.

Table 15-1 PCI-to-VME Library Functions

Function	Description
<code>bt_str2dev</code>	Convert from string to logical device.
<code>bt_gen_name</code>	Generate the device name.
<code>bp_open</code>	Open a logical device for access.
<code>bt_close</code>	Close the logical device.
<code>bt_chkerr</code>	Check for errors on a unit.
<code>bt_clrerr</code>	Clear errors on a unit.
<code>bt_perror</code>	Print error message to stderr.
<code>bt_strerror</code>	Create a string error message.
<code>bt_init</code>	Initialize a unit.
<code>bt_read</code>	Read data from a logical device.
<code>bt_write</code>	Write data to a logical device.
<code>bt_get_info</code>	Get device configuration settings. See Note 1 below.
<code>bt_set_info</code>	Set device configuration settings. See Note 1 below.
<code>bt_icbr_install</code>	Install an interrupt call back routine.
<code>bt_icbr_remove</code>	Remove an interrupt call back routine.
<code>bt_lock</code>	Lock a unit.
<code>bt_unlock</code>	Unlock a previously locked unit.
<code>bt_mmap</code>	Create a memory mapped pointer into a logical device.
<code>bt_unmmap</code>	Unmap a memory mapped location.
<code>bt_dev2str</code>	Convert from a logical device type to a string.
<code>bt_ctrl</code>	Call directly into the driver I/O control function.
<code>bt_bind</code>	Bind application supplied buffers. See Note 1 below.
<code>bt_unbind</code>	Unbind bound buffers. See Note 1 below.
<code>bt_reg2str</code>	Convert register to string.
<code>bt_cas</code>	Compare and swap atomic transactions.
<i>(continued on next page)</i>	
Notes:	
1	Multiple buffers of various sizes are supported through these functions; see the “Bind Buffer Implementation” section.
2	This PCI-to-VME mapping/binding support is unique; see the “Mapping and Binding to VMEbus Space” section in this chapter.

Table 15-1 PCI-to-VME Library Functions (Continued)

Function	Description
bt_tas	Test and set atomic transaction.
bt_get_io	Read an adapter CSR register.
bt_put_io	Write an adapter CSR register.
bt_or_io	One shot a register.
bt_reset	Remotely reset the VMEbus.
bt_send_irq	Send an interrupt to the remote VMEbus.
bt_status	Return device status.
bt_hw_map_vme	Create a PCI-to-VMEbus mapping. See Note 2 below.
bt_hw_unmap_vme	Remove a PCI-to-VMEbus mapping. See Note 2 below.
Notes:	
1	Multiple buffers of various sizes are supported through these functions; see the “Bind Buffer Implementation” section.
2	This PCI-to-VME mapping/binding support is unique; see the “Mapping and Binding to VMEbus Space” section in this chapter.

Bind Buffer Implementation

The RedHawk sbsvme bind buffer support allows for multiple, different sized kernel bind buffers to be allocated, `bt_mmap()` and `bt_bound()` to VMEbus space at the same time. This section provides information about this bind buffer support, including how this support differs from the documentation on bind buffers in the SBS Technologies Software Manual.

Note that the only user interface difference between the SBS documentation and the RedHawk bind buffer implementation is in the use of the ‘value’ parameter on the `bt_set_info()` `BT_INFO_KFREE_BUF` call, which is discussed below. All other user interfaces are the same as shown in the SBS Technologies Software Manual.

`bt_get_info BT_INFO_KMALLOC_BUF`

Synopsis

```
bt_error_t bt_get_info(bt_desc_t btd, BT_INFO_KMALLOC_BUF,
    bt_devdata_t *value_p)
```

Multiple `bt_get_info()` `BT_INFO_KMALLOC_BUF` command calls can be made to allocate multiple kernel buffers, where each returned buffer address, which is stored at the `value_p` parameter location, may then be used on subsequent `bt_mmap()` and `bt_bind()` calls in order to `mmap` and bind this buffer to a location on the VMEbus.

`BT_INFO_KMALLOC_BUF` calls allocate a kernel bind buffer with a size equal to the last value set on the last successful `bt_set_info()` `BT_INFO_KMALLOC_SIZ` call. (If no such calls have been made when the `BT_INFO_KMALLOC_BUF` call is made, then the default size of 64 KB is used.)

Up to BT_KMALLOC_NBUFS (16) kernel buffers can be allocated at the same time with the BT_INFO_KMALLOC_BUF command. If there are already 16 bind buffers allocated, this BT_INFO_KMALLOC_BUF call fails and returns an error value of BT_EINVAL.

Note that if a bt_set_info() BT_INFO_KMALLOC_SIZ call is used to set the bind buffer size to zero, all subsequent BT_INFO_KMALLOC_BUF calls return with an error value of BT_EINVAL until a new bind buffer size is set to a non-zero value via a bt_set_info() BT_INFO_KMALLOC_SIZ call.

If the kernel is unable to allocate enough space for a new kernel bind buffer, this BT_INFO_KMALLOC_BUF call fails and returns an error value of BT_EINVAL.

bt_set_info BT_INFO_KMALLOC_SIZ

Synopsis

```
bt_error_t bt_set_info(bt_desc_t btd, BT_INFO_KMALLOC_SIZ,  
                      bt_devdata_t value)
```

When the bt_set_info() BT_INFO_KMALLOC_SIZ command is used to set a new bind buffer size, the command only affects future bt_get_info() BT_INFO_KMALLOC_BUF command calls. Any kernel bind buffers that have already been allocated with different bind buffer sizes are NOT affected by the new BT_INFO_KMALLOC_SIZ call.

In this way, different sized kernel bind buffers can be allocated by using a different BT_INFO_KMALLOC_SIZ 'value' parameter after making one or more bt_get_info() BT_INFO_KMALLOC_BUF calls.

It is encouraged, but not required, to use bind buffer sizes for the 'value' parameter that are a power of 2. Since the kernel bind buffer allocation is rounded up to a power of 2, specifying and using a power of 2 'value' parameter value eliminates unused sections of the allocated kernel bind buffers. Note that the initial default value for the kernel bind buffer size is 64 KB.

Typically, the maximum size kernel bind buffer that can be successfully allocated on a subsequent bt_get_info() BT_INFO_KMALLOC_BUF call is 4 MB. However, depending upon the amount of physical memory on the system and the other uses of system memory, it may not always be possible to successfully allocate a 4 MB kernel bind buffer. In this case, multiples of smaller sized bind buffers can be allocated, or alternatively, 4 MB kernel bind buffers can be allocated before other uses of system memory use up the memory resources.

bt_set_info BT_INFO_KFREE_BUF

Synopsis

```
bt_error_t bt_set_info(bt_desc_t btd, BT_INFO_KFREE_BUF,  
                      bt_devdata_t value)
```

The interface for the bt_set_info() BT_INFO_KFREE_BUF command is slightly different under RedHawk than what is documented in the SBS Technologies Software Manual.

Specifically, the 'value' parameter is not used in the SBS implementation but the RedHawk implementation uses this parameter in the following ways:

When the 'value' parameter is zero:

This call unbinds and frees *all* kernel bind buffers that are not currently `bt_mmap()`ed from user space. If at least one bind buffer is unbound and freed, a successful status (`BT_SUCCESS`) is returned.

If no bind buffers are found that can be unbound and freed, this call fails and `BT_EINVAL` is returned to the caller.

When the 'value' parameter is not equal to zero:

This call is for unbinding and freeing up just one specific kernel bind buffer. In this case, the caller's 'value' parameter should be equal to the kernel buffer address that was returned at the 'value_p' parameter location on the previous `bt_get_info()` `BT_INFO_KMALLOC_BUF` call.

If the buffer address specified in the 'value' parameter on this call does not correspond to a valid kernel bind buffer, this call fails and returns an error value of `BT_EINVAL`.

If the 'value' parameter on this call corresponds to a valid kernel bind buffer, but that buffer is currently `bt_mmap()`ed from user space, this call fails and a value of `BT_EFAIL` is returned. In this case, the buffer must first be `bt_unmmap()`ed before this call can succeed.

Additional Bind Buffer Information

The following sections describe additional areas where bind buffer support is affected under RedHawk.

The Bigphysarea Patch

The `bigphysarea` patch discussed in the SBS Technologies Software Manual is not supported or needed in the RedHawk `sbsvme btp` device driver. By using multiple large bind buffers, it is possible to support the full 16MB of VMEbus slave window space for accessing iHawk memory from the VMEbus.

Unloading the btp Module

The `sbsvme 'btp'` kernel module can not be unloaded while there are any kernel bind buffers currently `bt_mmap()`ed in a process' address space. Processes must first remove their mappings to kernel bind buffers with `bt_unmmap()` call(s) before the kernel driver module is unloaded.

When there are no bind buffers currently `bt_mmap()`ed from user space, the `btp` kernel module can be unloaded with a `"/etc/init.d/sbsvme stop"` command, and any kernel bind buffers currently allocated are implicitly unbound (if currently bound) from the hardware VMEbus slave window area and freed up for other future kernel memory allocations.

bt_bind rem_addr_p Parameter

The 'rem_addr_p' parameter on bt_bind() calls specifies an offset within the remote VMEbus slave window where the caller wishes to bind a kernel bind buffer. Note that this value is an offset, and not an absolute VMEbus physical address. This offset value is from the base VMEbus address defined by the REM-RAM LO jumper setting located on the SBS VME adapter card.

The user can either specify an actual 'rem_addr_p' offset value, or let the btp driver find an appropriate bind address location by using the BT_BIND_NO_CARE value for the 'rem_addr_p' parameter. When this value is used, upon successful return from the bt_bind() call the 'rem_addr_p' memory location contains the offset value where the kernel btp driver bound the bind buffer.

As an example, if the REM-RAM LO jumper settings are set to a value of 0xC0000000 and the offset value is 0x10000, the actual bind address where this buffer can be accessed from the VMEbus would be 0xC0010000.

Local Memory

In addition to the kernel bind buffer support, the btp driver also supports the concept of local memory. This feature is made available through use of the BT_DEV_LM device type, instead of the BT_DEV_A32, BT_DEV_A24, and other VMEbus device types typically used for the bind buffer feature.

The local memory buffer consists of local iHawk memory that is allocated and bound to the VMEbus slave window area when the btp driver is loaded. This memory allocation and binding remains in effect as long as the btp driver is loaded. If the btp driver is unloaded with a "/etc/init.d/sbsvme stop" command, this local memory buffer is unbound from VMEbus space and freed up for other kernel uses.

The local memory buffer is always bound to the bottom area of the VMEbus slave window as defined by the REM-RAM LO jumper settings on the VME adapter card. For example, if the local memory size is 64 KB, and the REM-RAM LO jumper settings are set to a value of 0xC0000000, the local memory buffer is bound to the VMEbus at physical VMEbus addresses 0xC0000000 through 0xC0000FFF.

Note that since the local memory buffer always occupies the bottom area of the VMEbus remote slave window, the kernel bind buffers may not be bound to this area whenever local memory support is enabled. By default, the local memory support is enabled with a local memory buffer size of 64 KB, which leaves 16 MB - 64 KB of VMEbus slave window space for bind buffers (assuming that the REM-RAM LO jumper settings are set to a range that covers 16 MB).

The size of the local memory buffer can be increased by modifying the 'lm_size' parameter in the `/etc/sysconfig/sbsvme` configuration file (see the "Configuration" section earlier in this chapter. Note that the maximum supported 'lm_size' value is 4 MB. If a larger value is specified, the btp driver's buffer allocation does not succeed, and the local memory feature is disabled at btp driver load time.

The local memory support can be disabled by setting the 'lm_size' btp module parameter to zero. When set to zero, the btp driver does not allocate a local memory buffer, and the entire VMEbus slave window area is free for kernel bind buffer use.

The local memory support is very similar to the bind buffer support:

- Both local memory and bind buffers are accessible from the VMEbus through the slave window area.
- Both the local memory and bind buffer buffer areas can be accessed by specifying the appropriate device type when using the `bt_read()`, `bt_write()` and `bt_mmap()` functions.

The main differences between the local memory and bind buffer support are:

- There may be only one local memory buffer area. This buffer is set up at `bt` driver load time and remains allocated and bound until the `bt` driver is unloaded.

Contrastingly, multiple bind buffers of different sizes can be dynamically allocated and bound, and dynamically unbound and freed.

- The local memory buffer always occupies the bottom of the VMEbus slave window area.

Contrastingly, for bind buffers the user can either specify the location/offset where each bind buffer is to be bound to VMEbus space, or let the kernel dynamically find the next free location/offset to use.

Mapping and Binding to VMEbus Space

RedHawk provides a method of creating VMEbus space mappings that are not associated with a specific process and remain intact after the process that created the mapping exits. These mappings can be created and removed independently, either through the `bt_hw_map_vme` and `bt_hw_unmap_vme` library functions or by writing to a `/proc` file system interface.

The unique PCI bus starting address that corresponds to an active VMEbus space area mapping can be obtained and used with `shmbind(2)` or `shmconfig(1)` to bind this segment to a region of I/O space.

This functionality is described in the sections that follow.

`bt_hw_map_vme`

This function creates a new PCI-to-VMEbus mapping.

Synopsis

```
bt_error_t bt_hw_map_vme(bt_desc_t btd, void **phys_addr_p,
                        bt_devaddr_t vme_addr, size_t map_len, bt_swap_t swapping)
```

Arguments

<code>btd</code>	the device descriptor that was returned from a successful <code>bt_open()</code> function call.
<code>phys_addr_p</code>	the user space location where the local PCI bus starting/base address for this mapping is returned

vme_addr	the starting/base target VMEbus physical address. This address must be aligned on a 4 KB boundary.
map_len	the size of hardware mapping to be created. This value is rounded up to a multiple of 4 KB.
swapping	the byte swapping method to use for hardware mapping. The BT_SWAP_XXX defines included in the <code>/usr/include/btp/btngpci.h</code> header file can be used.

Return Values

When successful, a value of BT_SUCCESS is returned. The PCI bus address returned at the `phys_addr_p` location can be used with `shmbind(2)` or `shmconfig(1)` to create a shared memory area that may be used to access this range of remote VMEbus addresses.

When unsuccessful, an appropriate `bt_error_t` value is returned indicating the reason for the failure:

BT_EDESC	An invalid <code>btd</code> descriptor was specified. The descriptor must be a descriptor returned from a <code>bt_open()</code> call of a BT_DEV_A32, BT_DEV_A24 or BT_DEV_A16 device type.
BT_EINVAL	An invalid <code>vme_addr</code> , <code>map_len</code> , <code>phys_addr_p</code> or <code>swapping</code> parameter was specified.
BT_ENXIO	The sbsvme hardware is not online or not connected properly.
BT_ENOMEM	The required number of sbsvme hardware mapping registers could not be allocated.
BT_ENOMEM	The memory for the kernel data structures that are used for tracking this mapping could not be allocated.

bt_hw_unmap_vme

This function removes a PCI-to-VMEbus mapping previously created with the `bt_hw_map_vme` function or by writing to the `/proc/driver/btp/unit/vme-mappings` file.

Synopsis

```
bt_error_t bt_hw_unmap_vme(bt_desc_t btd, void *phys_addr)
```

Parameters

btd	the device descriptor that was returned from a successful <code>bt_open()</code> function call.
phys_addr	the PCI bus starting address for the VMEbus mapping to be removed

Return Values

When successful, a value of `BT_SUCCESS` is returned.

When unsuccessful, an appropriate `bt_error_t` value is returned indicating the reason for the failure:

<code>BT_EDESC</code>	An invalid <code>bt_d</code> descriptor was specified. The descriptor must be a descriptor that was returned from a <code>bt_open()</code> call of a <code>BT_DEV_A32</code> , <code>BT_DEV_A24</code> or <code>BT_DEV_A16</code> device type.
<code>BT_ENOT_FOUND</code>	The mapping specified by the <code>phys_addr</code> parameter does not exist.

The /proc File System Interface

When the `sbsvme` `btp` kernel module is loaded, the following `/proc` file(s) are created:

`/proc/driver/btp/unit/vme-mappings`

where `unit` is the unit number of the `sbsvme` PCI bridge card. The first card is unit number 0. On systems with multiple bridges, the second card is unit number 1, etc.

Existing PCI-to-VMEbus mappings can be viewed by reading the file. Mappings can be created and removed by writing to the file. These techniques are described below.

Displaying VMEbus Mappings

Reading the `vme-mappings` file using `cat (1)` displays all currently established VMEbus mappings. The following output shows two PCI-to-VMEbus mappings:

```
$ cat /proc/driver/btp/0/vme-mappings
pci=0xf8019000 vme=0x00008000 size=0x0001000 space=A16 admod=0x2d swap=5
pci=0xf8011000 vme=0x00fe0000 size=0x0008000 space=A24 admod=0x39 swap=0
```

<code>pci=</code>	indicates the local PCI bus address where the mapping begins
<code>vme=</code>	indicates the starting VMEbus address
<code>size=</code>	indicates the size/length of the mapping
<code>space=</code>	indicates the VMEbus address space type for the mapping
<code>admod=</code>	indicates the VMEbus address modifier described by the <code>BT_AMOD_XXX</code> defines in <code>/usr/include/btp/btdef.h</code> .
<code>swap=</code>	indicates the bit swapping method described by the <code>BT_SWAP_XXX</code> defines in <code>/usr/include/btp/btngpci.h</code> .

Creating VMEbus Mappings

Mappings to VMEbus space can be created by writing to the `vme-mappings` file. Note that you must have `CAP_SYS_ADMIN` privileges to write to this file. To create a mapping, the following three parameters must be specified in the order given here:

<code>vme=</code>	specifies the starting, page-aligned VMEbus address to be mapped (e.g., <code>0xffff000</code>).
-------------------	---

`size=` specifies the size of the mapping, which should be a multiple of a page (e.g., 0x1000). Note that the sbsvme hardware is limited to mapping a total of 32 MB of VMEbus space.

`space=` specifies the VMEbus address space type for the mapping: A32, A24 or A16.

The following optional parameters may also be supplied, in any order, following the required parameters listed above:

`admod=` specifies the VMEbus address modifier described by the `BT_AMOD_xxx` defines in `/usr/include/btp/btdef.h`. If not specified, the following default values are used:

```
BT_AMOD_32    0x0d
BT_AMOD_24    0x3d
BT_AMOD_16    0x2d
```

`swap=` specifies the bit swapping method described by the `BT_SWAP_xxx` defines in `/usr/include/btp/btngpci.h`. If not specified, the default `BT_SWAP_DEFAULT` value is used.

The following example shows creating two VMEbus mappings by writing to the `vme-mappings` file.

```
$ echo "vme=0xe1000000 size=0x10000 space=A32" > /proc/driver/btp/0/vme-mappings
$ echo "vme=0xc0000000 size=0x1000 space=A32 swap=7 admod=0x9" > /proc/driver/btp/0/vme-mappings
```

Note that when the sbsvme btp kernel driver is unloaded with `"/etc/init.d/sbsvme stop"` (see "VMEbus Mappings"), all current VMEbus mappings are removed before the driver is unloaded. If mappings exist and `"modprobe -r btp"` is used to unload the driver, the unload will fail until all VMEbus mappings are removed.

Removing VMEbus Mappings

A mapping to VMEbus space can be removed by writing the local PCI bus location of the mapping to the `vme-mappings` file. Note that you must have `CAP_SYS_ADMIN` privileges to write to this file. The PCI bus location is returned by `bt_hw_map_vme()` and by `cat`'ing the `vme-mappings` file. For example:

```
$ cat /proc/driver/btp/0/vme-mappings
pci=0xf8019000 vme=0x00008000 size=0x0001000 space=A16 admod=0x2d swap=5
pci=0xf8011000 vme=0x00fe0000 size=0x0008000 space=A24 admod=0x39 swap=0

$ echo "pci=0xf8019000" > /proc/driver/btp/0/vme-mappings

$ cat /proc/driver/btp/0/vme-mappings
pci=0xf8011000 vme=0x00fe0000 size=0x0008000 space=A24 admod=0x39 swap=0
```

Example Applications

Example programs are supplied that demonstrate features of the sbsvme btp device driver and facilitate its use. They can be found in `/usr/share/doc/ccur/examples/sbsvme`. The programs are useful tools for:

- debugging
- uploading and downloading binary data
- receiving and counting programmed interrupts
- testing hardware
- creating VMEbus mappings and bindings to shared memory areas

Table 15-2 lists the example programs. An asterisk (*) indicates the program was added to RedHawk Linux and is described in the following sections. Other programs are described in the SBS Technologies Software Manual.

Table 15-2 PCI-to-VME Example Programs

Name	Description	Functions Used
bt_bind	Binds a local buffer to the remote VMEbus, waits for user input, and then prints the first 256 bytes of the bound buffer.	bt_bind() bt_unbind()
bt_bind_mult *	Shows how to bind multiple local buffers to the remote VMEbus. Optionally writes values to the local buffers before waiting for user input. After user input occurs, it prints out the first 16 bytes of each page of each of the local buffers.	bt_bind() bt_unbind()
bt_bind_multsz *	Shows how to create multiple bind buffers with different sizes.	bt_bind() bt_unbind()
bt_cat	Similar to the 'cat' program. Allows reading from the remote VMEbus to stdout, or writing data to the remote VMEbus from stdin.	bt_read() bt_write()
bt_datachk	Reads and writes from a device using a specific pattern and then verifies that no data or status errors occurred.	bt_read() bt_write()
bt_dumpmem	Reads and prints to stdout 256 bytes of remote VMEbus data.	bt_mmap()
bt_getinfo	A script that gets all the driver parameters and displays their values to stdout.	n/a
bt_hwmap *	Creates a VMEbus mapping.	bt_hw_map_vme()
bt_hwunmap *	Removes a VMEbus mapping.	bt_hw_unmap_vme()
bt_icbr	Registers for and receives interrupts for a given interrupt type.	bt_icbr_install() bt_icbr_remove()
bt_info	Gets or sets driver parameters.	bt_get_info() bt_set_info()
bt_readmem	Reads and prints to stdout 256 bytes of remote VMEbus data.	bt_read()
bt_reset	Resets the remote VMEbus.	bt_reset()

(continued on next page)

Table 15-2 PCI-to-VME Example Programs (Continued)

Name	Description	Functions Used
bt_revs	Outputs the software driver version and hardware firmware version information to stdout.	bt_open()
bt_sendi	Sends an interrupt to the remote bus.	bt_send_irq()
readdma *	Same as readmem, except this program reads larger amounts of data, which results in the DMA hardware being used in the kernel driver instead of cpu copying the data.	bt_read()
shmat *	Takes a shared memory key parameter to attach and read from a shared memory area. Used by the shmconfig-script program.	shmconfig(1) shmat(2)
shmbind *	Creates and attaches to a shared memory area that is mapped to a PCI-to-VMEbus mapping and reads or writes to it.	shmget(2) shmbind(2) shmat(2)
shmconfig-script *	A script that creates a PCI-to-VMEbus mapping via the <code>/proc</code> file system and creates a shared memory area that is bound to the VMEbus area.	shmconfig(1)
vme-mappings *	A script that shows how to create, display and remove PCI-to-VMEbus mappings via the <code>/proc</code> file system.	n/a
writemem *	Writes out 256 bytes of data to the remote VMEbus, reads the 256 bytes of data back from the remote VMEbus and then outputs this data to stdout.	bt_read() bt_write()
writedma *	Same as writemem, except this program writes larger amounts of data, which results in the DMA hardware being used in the kernel driver instead of cpu copying the data. This example only writes the data to the remote VMEbus; it does not read the data back from the remote VMEbus.	bt_write()

bt_bind_mult

The `bt_bind_mult` example application uses the `bt_bind()` function to bind multiple equally-sized buffers to the remote bus. It waits for user input, then prints the first 4 words of each page of each bound buffer. It also optionally writes data to buffer before waiting.

Usage: `bt_bind_mult -[natulws]`

OPTION	FUNCTION
-n <nbufs>	Number of buffers to allocate and bind. Default is 2.
-a <vmeaddr>	VME address to bind buffer. Defaults to <code>BT_BIND_NO_CARE</code> .
-t <logdev>	Logical device. (<code>BT_DEV_MEM</code> , <code>BT_DEV_IO</code> , <code>BT_DEV_DEFAULT</code> , etc.) Default is to <code>BT_DEV_DEFAULT</code> .
-u <unit>	Unit number to open. Default is unit 0.
-l <len>	Length of the buffer to bind. Default is one page.
-w <value>	Initially write this value to the first 4 words of each page in the buffer.
-s <swapbits>	Sets the swap bits value for the call to <code>bt_bind()</code> . Note that the symbolic names are not recognized.

bt_bind_multsz

The `bt_bind_multsz` example application uses the `bt_bind()` function to bind multiple buffers of various sizes to the remote bus. It waits for user input, then prints the first 4 words of each page of each bound buffer. It also optionally writes data to buffer before waiting.

Usage: `bt_bind_multsz -[atuws]`

OPTION	FUNCTION
<code>-a <vmeaddr></code>	VME address to bind buffer. Defaults to <code>BT_BIND_NO_CARE</code> .
<code>-t <logdev></code>	Logical device. (<code>BT_DEV_MEM</code> , <code>BT_DEV_IO</code> , <code>BT_DEV_DEFAULT</code> , etc.) Default is to <code>BT_DEV_DEFAULT</code> .
<code>-u <unit></code>	Unit number to open. Default is unit 0.
<code>-w <value></code>	Initially write this value to the first 4 words of each page in the buffer.
<code>-s <swapbits></code>	Sets the swap bits value for the call to <code>bt_bind()</code> . Note that the symbolic names are not recognized.

bt_hwmap

The `bt_hwmap` example application uses the `bt_hw_map_vme` function to create a hardware mapping to an area of VMEbus space.

Usage: `bt_hwmap -a[ltus]`

OPTION	FUNCTION
<code>-a <addr></code>	VMEbus physical address. This argument is required.
<code>-l <len></code>	Length of VMEbus area to map onto the PCI bus. Default is one page (0x1000).
<code>-t <logdev></code>	Logical device to access. (<code>BT_DEV_A32</code> , <code>BT_DEV_A24</code> , <code>BT_DEV_A16</code> , <code>BT_DEV_IO</code> , <code>BT_DEV_RR</code>). Default is to <code>BT_DEV_A32</code> .
<code>-u <unit></code>	Unit number to open. Default is unit 0.
<code>-s <swapbits></code>	Sets the swap bits value for the call to <code>bt_bind()</code> . Note that the symbolic names are not recognized. Default is <code>BT_SWAP_DEFAULT</code> .

bt_hwunmap

The `bt_hwmap` example application uses the `bt_hw_unmap_vme` function to remove a hardware mapping from an area of VMEbus space.

Usage: `bt_hwunmap -p[tu]`

OPTION	FUNCTION
<code>-p <pciaddr></code>	Local PCI bus physical address of the mapping to be removed. This argument is required.
<code>-t <logdev></code>	Logical device. (<code>BT_DEV_A32</code> , <code>BT_DEV_A24</code> , <code>BT_DEV_A16</code> , <code>BT_DEV_IO</code> , <code>BT_DEV_RR</code>). Default is to <code>BT_DEV_A32</code> .
<code>-u <unit></code>	Unit number to open. Default is unit 0.

readdma

This example program is the same as `bt_readmem`, except it reads larger amounts of data, which results in the DMA hardware being used in the kernel driver instead of CPU copying the data.

Usage: `readdma -[atulo]`

OPTION	FUNCTION
-a <addr>	Address at which to start data transfer. Default = 0x00000000.
-t <logdev>	Logical device to access. Default is to BT_DEV_A32.
-u <unit>	Unit number to open. Default is unit 0.
-l <length>	Bytes to read. Round down to pagesize. Default is 0x1000.
-o <outlen>	Number of bytes output at the start of each page boundary. Default is 16 bytes. This value must be <= 409.

shmat

This example program is invoked by the `shmconfig-script` script. It takes the shared memory 'key' value and attaches to and reads from the shared memory area that is bound to VMEbus space.

Usage: `shmat -k shmkey -s size [-o outlen]`

OPTION	FUNCTION
-k <shmkey>	Shared memory key value, in decimal, or in hex with a leading '0x' or '0X'.
-s <size>	Size in bytes of the shared memory area.
-o <outlen>	Number of bytes at the start of each shared memory page to output to stdout, in hex. Default is 32 bytes.

shmbind

This example program uses `shmget(2)`, `shmbind(2)` and `shmat(2)` to attach a shared memory area to a PCI-to-VMEbus mapping. You can read or write to the VMEbus space using the shared memory attached area. The PCI-to-VME hardware mapping needs to already be created.

Usage: `shmbind -p pci_addr -s size [-r | -w value] [-o len]`

OPTION	FUNCTION
-p <pci_addr>	Local PCI bus address where VME mapping is located, in hex.
-s <size>	Size in bytes of the shared memory area to create, in hex.
-r	Read from the shared memory area. (Default.)
-w <value>	Write to the shared memory area, using the specified value, in hex.
-o <len>	Number of bytes at the start of each shared memory page to output to stdout, in hex. Default is 32 bytes.

shmconfig-script

This is an example script of how to use **shmconfig(1)** to create a shared memory area that is bound to a specific VMEbus area with a PCI-to-VMEbus mapping. This script invokes the shmat example program after the shared memory area is created.

vme-mappings

This is an example script that shows how to create, examine and remove PCI-to-VMEbus mappings using the `/proc/driver/btp/unit/vme-mappings` file.

writemem

This example program uses the `bt_write()` Bit 3 Mirror API function to write to any of the Bit 3 logical devices.

Usage: `writemem -[atud]`

OPTION	FUNCTION
-a <addr>	Address at which to start data transfer. Default = 0x00000000.
-t <logdev>	Logical device to access (BT_DEV_RDP, BT_DEV_A32, etc.)
-u <unit>	Unit number to open. Default is unit 0.
-d <value>	Starting data value to write. Default is 0.

All numeric values use C radix notation.

Example: Write the first 256 bytes of data from BT_DEV_RDP starting at address 0x00001000:

```
./writemem -a 0x00001000
```

writedma

This example program is the same as `writemem`, except it writes larger amounts of data, which results in the DMA hardware being used in the kernel driver instead of cpu copying the data. This example only writes the data to the remote VMEbus; it does not read the data back from the remote VMEbus.

Usage: `writedma -[atuld]`

OPTION	FUNCTION
-a <addr>	Starting VME address. Default = 0x00000000.
-t <logdev>	Logical device to access. Default is to BT_DEV_A32.
-u <unit>	Unit number to open. Default is unit 0.
-l <length>	Number of bytes to write. Round down to pagesize. Default is 0x1000.
-d <value>	Starting data value to write. Default is 0.

Example Message Queue Programs

This appendix contains example programs that illustrate the use of the POSIX and System V message queue facilities. Additional example programs are provided online in the `/usr/share/doc/ccur/examples` directory.

POSIX Message Queue Example

The example program given here is written in C. In this program, a parent process opens a POSIX message queue and registers to be notified via a real-time signal when the queue transitions from empty to non-empty. The parent spawns a child and waits on the child until the child sends a message to the empty queue. The child sends the message, closes its descriptor and exits.

The parent receives the real-time signal and captures the `sigev_value` (`si_value`) as delivered by the `siginfo_t` structure in the signal handler. The parent also tests delivery of the `si_code` (`SI_MSGQ`) before receiving the child's test message. The parent verifies that delivery of the `si_value` (which is a union) was correct as previously registered by the `sigev_value`. The signal handler also displays the real-time signal value received (`SIGRTMAX`) using `psignal`. The `psignal` function doesn't know how to name `SIGRTMAX`, so it calls it an unknown signal, prints the value and exits.

To build this program, specify the following:

```
gcc mq_notify_rtsig.c -Wall -g -l rt -o mq_notify_rtsig
```

```
#include <sys/types.h>
#include <sys/stat.h>
#include <sys/wait.h>
#include <sys/time.h>
#include <unistd.h>
#include <mqueue.h>
#include <stdlib.h>
#include <ctype.h>
#include <stdio.h>
#include <errno.h>
#include <string.h>
#include <fcntl.h>
#include <time.h>
#include <sched.h>
#include <signal.h>
#include <bits/siginfo.h>

#define MSGSIZE 40
#define MAXMSG 5
#define VAL 1234
```

```

void handlr(int signo, siginfo_t *info, void *ignored);

int val, code;

int main(int argc, char **argv)
{
    struct sigaction act;
    struct sigevent notify;
    struct mq_attr attr;
    sigset_t set;
    char *mqname = "/mq_notify_rtsig";
    char rcv_buf[MSGSIZE];
    mqd_t mqdes1, mqdes2;
    pid_t pid, cpid;
    int status;

    memset(&attr, 0, sizeof( attr));

    attr.mq_maxmsg = MAXMSG;
    attr.mq_msgsize = MSGSIZE;

    mq_unlink(mqname);

    mqdes1 = mq_open(mqname, O_CREAT|O_RDWR, 0600, &attr);

    sigemptyset(&set);
    act.sa_flags = SA_SIGINFO;
    act.sa_mask = set;
    act.sa_sigaction = handlr;
    sigaction(SIGRTMAX, &act, 0);

    notify.sigev_notify = SIGEV_SIGNAL;
    notify.sigev_signo = SIGRTMAX;
    notify.sigev_value.sival_int = VAL;

    mq_notify(mqdes1, &notify);

    printf("\nmq_notify_rtsig:\tTesting notification sigev_value\n\n");

    printf("mq_notify_rtsig:\tsigev_value=%d\n", \
        notify.sigev_value.sival_int);

    if( (pid = fork()) < 0) {
        printf("fork: Error\n");
        printf("mq_notify_rtsig: Test FAILED\n");
        exit(-1) ;
    }

    if(pid == 0) { /* child */

        cpid = getpid() ;

        mqdes2 = mq_open(mqname, O_CREAT|O_RDWR, 0600, &attr);

        printf("child:\t\ttsending message to empty queue\n");

        mq_send(mqdes2, "child-test-message", MSGSIZE, 30);

```

System V Message Queue Example

The example program given here is written in C. In this program, a parent process spawns a child process to off load some of its work. The parent process also creates a message queue for itself and the child process to use.

When the child process completes its work, it sends the results to the parent process via the message queue and then sends the parent a signal. When the parent process receives the signal, it reads the message from the message queue.

```
#include <stdio.h>
#include <sys/types.h>
#include <sys/ipc.h>
#include <sys/msg.h>
#include <signal.h>
#include <errno.h>

#define MSGSIZE 40/* maximum message size */
#define MSGTYPE 10/* message type to be sent and received */

/* Use a signal value between SIGRTMIN and SIGRTMAX */
#define SIGRT1(SIGRTMIN+1)

/* The message buffer structure */
struct my_msgbuf {
    long mtype;
    char mtext[MSGSIZE];
};
struct my_msgbuf msg_buffer;

/* The message queue id */
int msqid;

/* SA_SIGINFO signal handler */
void sighandler(int, siginfo_t *, void *);

/* Set after SIGRT1 signal is received */
volatile int done = 0;

pid_t parent_pid;
pid_t child_pid;

main()
{
    int retval;
    sigset_t set;
    struct sigaction sa;

    /* Save off the parent PID for the child process to use. */
    parent_pid = getpid();

    /* Create a private message queue. */
    msqid = msgget(IPC_PRIVATE, IPC_CREAT | 0600);
    if (msqid == -1) {
        perror("msgget");
        exit(-1);
    }
}
```

```

/* Create a child process. */
child_pid = fork();

if (child_pid == (pid_t)-1) {
    /* The fork(2) call returned an error. */
    perror("fork");

    /* Remove the message queue. */
    (void) msgctl(msqid, IPC_RMID, (struct msqid_ds *)NULL);

    exit(-1);
}

if (child_pid == 0) {
    /* Child process */

    /* Set the message type. */
    msg_buffer.mtype = MSGTYPE;

    /* Perform some work for parent. */
    sleep(1);

    /* ... */

    /* Copy a message into the message buffer structure. */
    strcpy(msg_buffer.mtext, "Results of work");

    /* Send the message to the parent using the message
     * queue that was inherited at fork(2) time.
     */
    retval = msgsnd(msqid, (const void *)&msg_buffer,
                    strlen(msg_buffer.mtext) + 1, 0);

    if (retval) {
        perror("msgsnd(child)");

        /* Remove the message queue. */
        (void) msgctl(msqid, IPC_RMID, (struct msqid_ds *)NULL);

        exit(-1);
    }

    /* Send the parent a SIGRT signal. */
    retval = kill(parent_pid, SIGRT1);
    if (retval) {
        perror("kill SIGRT");

        /* Remove the message queue. */
        (void) msgctl(msqid, IPC_RMID, (struct msqid_ds *)NULL);
        exit(-1);
    }
    exit(0);
}

/* Parent */

/* Setup to catch the SIGRT signal. The child process
 * will send a SIGRT signal to the parent after sending
 * the parent the message.
 */
sigemptyset(&set);
sa.sa_mask = set;
sa.sa_sigaction = sighandler;

```

```

sa.sa_flags = SA_SIGINFO;
sigaction(SIGRT1, &sa, NULL);

/* Do not attempt to receive a message from the child
 * process until the SIGRT signal arrives. Perform parent
 * workload while waiting for results.
 */
while (!done) {
    /* ... */
}

/* Remove the message queue.
(void) msgctl(msqid, IPC_RMID, (struct msqid_ds *)NULL);
*/

/* All done.
*/
exit(0);
}

/*
 * This routine reacts to a SIGRT1 user-selected notification
 * signal by receiving the child process' message.
 */
void
sighandler(int sig, siginfo_t *sip, void *arg)
{
    int retval;
    struct ucontext *ucp = (struct ucontext *)arg;

    /* Check that the sender of this signal was the child process.
    */
    if (sip->si_pid != child_pid) {
        /* Ignore SIGRT from other processes.
        */
        printf("ERROR: signal received from pid %d\n", sip->si_pid);
        return;
    }

    /* Read the message that was sent to us.
    */
    retval = msgrcv(msqid, (void*)&msg_buffer,
        MSGSIZE, MSGTYPE, IPC_NOWAIT);

    done++;

    if (retval == -1) {
        perror("mq_receive (parent)");
        return;
    }

    if (msg_buffer.mtype != MSGTYPE) {
        printf("ERROR: unexpected message type %d received.\n",
            msg_buffer.mtype);
        return;
    }

    printf("message type %d received: %s\n",
        msg_buffer.mtype, msg_buffer.mtext);
}

```

Kernel Tunables for Real-time Features

Table B-1 contains a list of unique features in RedHawk Linux and the kernel configuration settings that support them. These include features developed by Concurrent for real-time operation, optional package support and features incorporated from open source patches.

For each function, the Kernel Configuration GUI option and the tunable name are given to help you view and modify the settings as needed. Additionally, the default settings for each feature in each of the RedHawk Linux pre-built kernels are provided. For more information about configuring and building a kernel, see Chapter 11.

Information about individual features is available in various locations. In Table B-1, the following references are provided:

- Page numbers (active hypertext links) where information included in this *RedHawk Linux User's Guide* is provided.
- Names and publication numbers of other appropriate Concurrent documents.

Other sources where information may be obtained include:

- Information provided in a separate help window of the Kernel Configuration GUI that displays when the parameter is selected.
- Text files in the **Documentation** directory of the kernel source tree.
- Linux documentation sites on the Internet.

Table B-1 Kernel Tunables for Real-time Features

Functionality	Kernel Configuration GUI Option	Tunable Name	Default Settings*/ Pre-built Kernels	Concurrent Documentation Reference
Shielded CPUs				
Enable CPU Shielding	General Setup	SHIELD	Y / all	page 2-1
Enable CPU Downing		CPU_IDLING	Y / all	page 2-28
RCU Processing		RCU_ALTERNATIVE	Y / all	page 7-4
Lock per-CPU daemons to their CPUs		DAEMON_CPU_LOCK	Y / all	n/a
Rescheduling Variables	General Setup	RESCHED_VAR	Y / all	page 5-3
Timekeeping				
Enable tickless system	Processor Type and Features	NO_HZ	Y / all	page I-1
Enable/disable tickless system at system boot		NO_HZ_ENABLED	Y / all	
High Resolution Process Accounting	General Setup	HRACCT	Y / all	page 7-2
TSC Reliability	Processor Type and Features	REQUIRE_TSC	Y / all i386	page 7-2
		REQUIRE_RELIABLE_TSC	Y / all	
Enable RCIM as system clocksource	Device Drivers	RCIM_CLOCKSOURCE	Y / all	RCIM User's Guide (0898007)
RCIM PPS support		RCIM_PPS	Y / all	RCIM User's Guide (0898007)
PPS API support		PPSAPI	Y / all	
PPS API on serial		PPSAPI_SERIAL	Y / all	
NTP Support for PPS	Processor Type and Features	NTP_PPS	Y / all	
RCIM Support	Device Drivers	RCIM	Y / all	RCIM User's Guide (0898007)
POSIX Message Queues	General Setup	POSIX_MQUEUE	Y / all	page 3-2
Post/Wait Support	General Setup	POST_WAIT	Y / all	page 5-37
Inherit Capabilities Across exec	General Setup	INHERIT_CAPS_ACROSS_EXEC	Y / all	page 13-5
* Y = set, N = not set, M = tunable enabled when kernel module is loaded				

Table B-1 Kernel Tunables for Real-time Features (Continued)

Functionality	Kernel Configuration GUI Option	Tunable Name	Default Settings*/ Pre-built Kernels	Concurrent Documentation Reference
Process Scheduling	Processor Type and Features	SCHED_SMT	Y / all	page 2-34
		SCHED_SMT_IDLE	N / all	
Optional RedHawk Products				
Frequency-based Scheduler (FBS)	Frequency-Based Scheduling	FBSCHED	Y / all	FBS User's Guide (0898005)
Performance Monitor (PM)	Frequency-Based Scheduling	FBSCHED_PM	Y / all	FBS User's Guide (0898005)
SNARE Audit	General Setup	AUDIT	N / all	RedHawk-FAQ
SBS VMEbus-to-PCI	Device Drivers	SBSVME	M / all	page 15-1
/proc Filesystem				
/proc/ccur	Pseudo File Systems	PROC_CCUR_DIR	Y / all	n/a
/proc/pid/affinity		PROC_PID_AFFINITY	Y / all	n/a
/proc/pid/resmem		PROC_PID_RESMEM	Y / all	n/a
PCI BAR Access	Bus options	PROC_PCI_BARMAP	Y / all	page 14-1
Memory Mapping				
Process space mmap/ usermap support	Pseudo File Systems	PROCMEM_MMAP	Y / all	page 9-1
File permission access to another process' address space		PROCMEM_ANYONE	Y / all	
Enable writes into another process' address space		PROCMEM_WRITE	Y / all	
Interrupt Processing				
Softirq daemon priority	General Setup	SOFTIRQ_PRI	0 / all	page 14-12
Softirq preemption blocking		SOFTIRQ_PREEMPT_BLOCK	Y / all	
Enable RCIM IRQ extensions	Device Drivers	RCIM_IRQ_EXTENSIONS	Y / all	RCIM User's Guide (0898007)
* Y = set, N = not set, M = tunable enabled when kernel module is loaded				

Table B-1 Kernel Tunables for Real-time Features (Continued)

Functionality	Kernel Configuration GUI Option	Tunable Name	Default Settings*/ Pre-built Kernels	Concurrent Documentation Reference
Full 4GB address range for read(1), write(1)	Pseudo File Systems	UNSIGNED_OFFSETS	Y / all	n/a
Enable shmbind call	Kernel Tracing	SHMBIND	Y / all	page 3-16
Kernel Virtual Address Space for Dynamic Allocation	General Setup	VMALLOC_RESERVE	128 / all i386 4096 / all x86_64	page 14-11
Cross Processor Interrupt Reduction				
Preload vmalloc page tables at boot	General Setup	VMALLOC_PGTABLE_PRELOAD	Y / generic (i386 non-PAE only)	page G-5
Graphic Page Preallocation	Device Drivers	PREALLOC_GRAPHICS_PAGES	10240 / all	page G-3
Softlockup detection	Kernel Hacking	DETECT_SOFTLOCKUP	N / all	page 2-34
Lock break handling	General Setup	LOCK_BREAK_THROTTLE	Y / all	n/a
		LOCK_BREAK_THROTTLE_LIMIT	30 / all	n/a
XFS Filesystem				
Enable XFS	File Systems	XFS_FS	Y / all	page 8-1
Real-time subvolume support		XFS_RT	Y / all	
Kernel Preemption	Processor Type and Features	PREEMPT	Y / all	page 1-6
Ptrace Extensions	General Setup	PTRACE_EXT	Y / all	page 1-6
NUMA Support	Processor Type and Features	NUMA	Y / all	page 10-1
		K8_NUMA	Y / all x86_64 only	
		X86_64_ACPI_NUMA	Y / all x86_64 only	
		PAGE_REPLICATION	Y / all	
		PAGE_REPLICATION_DYNAMIC	Y / all	
		MEMSHIELD_ZONE_NORMAL	Y / all x86 only	
MEMSHIELD_ZONELIST_ORDER	Y / all			
* Y = set, N = not set, M = tunable enabled when kernel module is loaded				

Table B-1 Kernel Tunables for Real-time Features (Continued)

Functionality	Kernel Configuration GUI Option	Tunable Name	Default Settings*/ Pre-built Kernels	Concurrent Documentation Reference
System Dumps				
Enable kdump crash dumps	Processor Type and Features	KEXEC	Y / all	page 12-1
Generate debug symbols		DEBUG_INFO	Y / all	
Enable kernel crash dumps		CRASH_DUMP	Y / kdump only	
Kernel Debug				
KDB support	Kernel Hacking	KDB	Y / debug only	page 12-8
KDB support		KDB_OFF	N / debug only	
Include Concurrent support		KDB_MODULES	Y / debug only	
KDB catastrophic error handling		KDB_CONTINUE_CATASTROPHIC	0 / debug only	
Kernel Tracing				
Enable kernel tracing	Kernel Tracing	TRACE	Y / trace, debug N / generic	page D-1
Use RCIM as timestamp source		TRACE_USE_RCIM	Y / debug, trace N / generic	n/a
nVIDIA Graphics Support	Device Drivers	NVIDIA	M / all	Release Notes (0898003)
Hyper-threading	Processor Type and Features	X86_HT	Y / all	page 2-28
UIO Support	Userspace I/O	UIO	Y / all	page 14-15
* Y = set, N = not set, M = tunable enabled when kernel module is loaded				

This appendix lists the capabilities included in RedHawk Linux and the permissions that each capability provides.

Overview

Capabilities is a method in Linux where the privileges traditionally associated with superuser are divided into distinct units that can be independently enabled and disabled. An unscrupulous user can use some of the permissions provided by capabilities to defeat the security mechanisms provided by Linux; therefore, this functionality should be used with due caution. Capabilities are defined in `/usr/include/linux/capability.h`.

For more information about how capabilities work in Linux, refer to the `capabilities(7)` man page. For information about the PAM facility that provides an authentication scheme utilizing capabilities, refer to Chapter 13.

Capabilities

This section describes the permissions provided by each of the capabilities defined under RedHawk Linux. Features from standard Linux as well as features unique to RedHawk Linux are included in this discussion.

CAP_CHOWN This capability overrides the restriction of changing user or group file ownership when the current effective user ID, group ID, or one of the supplemental group IDs do not match the file's UID/GID attributes.

CAP_DAC_OVERRIDE

Except for the file access restrictions enforced by files marked as immutable or append-only (see `chattr(1)`), this capability overrides any file discretionary access control (DAC) restrictions that would normally be enforced with the owner/group/world read/write/execute filesystem permission attributes and Access Control List (ACL) restrictions, if ACL support is configured into the kernel for that filesystem (see `acl(5)` for more details).

Read and write access DAC restrictions may always be overridden with this capability. Execute DAC restrictions may be overridden with the capability as long as at least one owner/group/world execute bit is set.

This capability also overrides permission access restrictions when using the `fsintrpt(3)` and `fsresume(3)` commands.

CAP_DAC_READ_SEARCH

This capability overrides any file discretionary access control (DAC) restrictions that would normally be enforced with the owner/group/world read/execute filesystem permission attributes and Access Control List (ACL) restrictions if ACL support is configured into the kernel for that filesystem (see **acl(5)** for more details).

This capability always allows read access to files and directories, and search (execute) access to directories.

This capability also overrides permission access restrictions when using the **fsintrpt(3)** and **fsresume(3)** commands.

CAP_FOWNER This capability:

- overrides all Discretionary Access Control (DAC) restrictions regarding file attribute changes where the file owner ID must be equal to the user ID.
- allows the FBS_RMID and FBS_SET **fsctl(2)** commands when the fbs creator user ID and user ID do not match the caller's effective user ID

This capability does not override Data Access Control (DAC) restrictions.

CAP_FSETID This capability overrides the restriction that the effective group ID (or one of the supplementary group IDs) shall match the file group ID when setting the S_ISGID bit on that file.

CAP_IPC_LOCK This capability allows for the locking of memory through the **mlock(2)** and **mlockall(2)** system service calls.

It also allows locking and unlocking of shared memory segments through the **shmctl(2)** SHM_LOCK and SHM_UNLOCK commands.

CAP_IPC_OWNER This capability overrides the IPC permission set that is associated with an IPC shared memory segment, message queue or semaphore array. The IPC permissions have the same format and meaning as the read/write owner, group and world permissions associated with files. Note that execute permissions are not used. The **ipcs(1)** command may be used to view the owner and permissions of the current IPC resources.

CAP_KILL This capability overrides the restriction that the real or effective user ID of a process sending a signal must match the real or effective user ID of the process receiving the signal.

This capability also overrides the restriction on KDSIGACCEPT **ioctl(2)** calls that requires the calling process to be the owner of the tty or have the CAP_SYS_TTY_CONFIG capability.

CAP_LEASE This capability lets a user take out a lease on a file, with the **fcntl(2)** F_SETLEASE command, even when the process' user ID does not match the file system user ID value.

CAP_LINUX_IMMUTABLE

This capability allows the modification of the `S_IMMUTABLE` and `S_APPEND` file attributes. See the `chattr(1)` man page for more information on these file attributes.

CAP_MKNOD

This capability allows the user to make use of the privileged aspects of `mknod(1)/mknod(2)`. It also allows use of the `XFS_IOC_FSSETDM_BY_HANDLE` xfs filesystem `ioctl(2)` command.

CAP_NET_ADMIN

This capability allows for the following network administration activities:

- setting debug and priority options on sockets
- administration of IP firewall, masquerading and accounting
- interface configuration
- multicasting
- reading and writing of network device hardware registers
- adding/deleting tunnels
- modification of routing tables
- setting TOS (type of service)
- activation of ATM control sockets

CAP_NET_BIND_SERVICE

This capability allows binding to TCP/UDP and Stream Control Transmission Protocol (SCTP) sockets below 1024, and to ATM VCIs below 32.

This capability also causes a reserved port to be used when creating an RPC client transport.

CAP_NET_BROADCAST

This capability is not currently used.

CAP_NET_RAW

This capability allows the creation of `SOCK_RAW` and `SOCK_PACKET` sockets, and the use of the `SO_BINDTODEVICE` `setsockopt(2)` socket option.

CAP_SETGID

This capability overrides the restrictions placed on non-root process' group ID value for the `setregid(2)`, `setgid(2)`, `setresgid(2)`, `setfsgid(2)` and `setgroups(2)` system services.

This capability also allows a process to send a socket level credential control message that contains a group ID value that does not match the current process' current, effective or saved group ID. (Additionally, the credential control message process ID must match the process' thread group ID or the process must also have the `CAP_SYS_ADMIN` capability, and the credential control message user ID must match the process' saved, effective or current user ID, or have the `CAP_SETUID` capability.)

CAP_SETPCAP

This capability allows a process to transfer any capability in the process' permitted set to any process ID (PID), and to remove any capability in the process' permitted set from any PID.

CAP_SETUID This capability allows setting the current user ID to any user ID, including the user ID of superuser. Extreme caution should be used in granting this capability.

This capability also allows a process to send a socket level credential control message that contains a user ID value that does not match the current process' current, effective or saved user ID. (Additionally, the credential control message process ID must match the process' thread group ID or the process must also have the `CAP_SYS_ADMIN` capability, and the credential control message group ID must match the process' saved, effective or current group ID, or have the `CAP_SETGID` capability.)

This capability also overrides the limitation that processes that are ptraced by this process may not inherit the user or group ID of a "set user or group ID on execution" executable that the ptraced process executes.

CAP_SYS_ADMIN This capability provides the following system administration activities:

- allows use of `bdflush(2)`
- overrides the open file limit
- allows examination and configuration of disk quotas
- allows examination and configuration of disk usage on a per user or per group basis under the xfs filesystem (if `XFS_QUOTA` is enabled)
- allows `umount()` and `mount()`
- allows copying of a process' namespace during `fork(2)/clone(2)` calls
- allows `msgctl(2)`, `semctl(2)` and `shmctl(2)` `IPC_SET` and `IPC_RMID` commands for message queues, semaphores and shared memory areas that do not have a user ID or creator user ID value that matches the process' effective user ID
- allows `shmctl(2)` `SHM_PHYSBIND` commands for shared memory areas where the user ID or creator user ID of the shared memory area does not match the process' effective user ID
- overrides the limit on the maximum number of processes per process on `fork(2)/clone(2)` calls when the non-root user does not have the `CAP_SYS_RESOURCE` capability
- allows wakeups on `pw_post(2)`, `pw_postv(2)`, `server_wake1(2)` and `server_wakevec(2)` calls when the process(es) to be awakened do not have the same user ID or saved user ID as the calling process' effective user ID or user ID value
- allows use of the `RCIM_WRITE_EEPROM` and `RCIM_TESTIRQ` `ioctl(2)` `RCIM` driver commands
- allows use of the system dump `ioctl(2)` commands, and the setting of the `sysctl(2)` `kernel.dump.device` variable
- allows configuration of serial ports
- allows `sethostname(2)` and `setdomainname(2)` calls
- allows the use of `swapon(8)` and `swapoff(8)` calls

- allows the open of raw volume zero and the CCISS_SETINTINFO and CCISS_SETNODENAME **ioctl(2)** commands in the Disk Array driver for HP SA 5xxx and 6xxx Controllers
- allows **ioctl(2)** commands in the Mylex DAC960 PCI RAID Controller driver
- allows the open of raw volume zero in the Compaq SMART2 Controller Disk Array driver
- allows the use of floppy root-only **ioctl(2)** commands (those commands with bit 0x80 set), and also the FDSETPRM and FDDEFPRM set geometry commands
- allows use of the following block device **ioctl(2)** commands: BLKPG add/delete partition, BLKRRPART re-read partition, BLKRASET set read-ahead for block device, BLKFRASET set filesystem read-ahead, BLKBSZSET set logical block size, BLKFLSBUF flush buffer cache, BLKROSET set device read-only
- allows setting the encryption key on loopback filesystems
- allows network block device **ioctl(2)** commands
- allows modification of the memory type range registers (MTRR)
- allows use of **ioctl(2)** commands for power management when APM is enabled in the kernel
- allows use of some **ioctl(2)** commands for certain BIOS settings
- allows use of the VM86_REQUEST_IRQ **vm86(2)** support
- allows use of the CDROMRESET, CDROM_LOCKDOOR and CDROM_DEBUG **ioctl(2)** CDROM commands
- allows DDIOCSDBG DDI debug **ioctl(2)** on sbpcd CDROM driver
- allows use of the root-only Direct Rendering Manager (DRM) **ioctl(2)** commands and the DRM **mmap(2)** DMA memory command
- allows use of the root-only **ioctl(2)** commands in the Specialix RIO smart serial card driver
- allows reading the first 16 bytes of the VAIO EEPROM hardware Sensors chip on the I2C serial bus
- allows writes to the **/proc/ide/iden/config** file, modification of the IDE drive settings, and the following IDE **ioctl(2)** commands: HDIO_DRIVE_TASKFILE (execute raw taskfile), HDIO_SET_NICE (set nice flags), HDIO_DRIVE_RESET (execute a device reset), HDIO_GET_BUSSTATE (get the bus state of the hardware interface), HDIO_SET_BUSSTATE (set the bus state of the hardware interface)
- allows use of the SNDRV_CTL_IOCTL_POWER sound **ioctl(2)** command
- allows the use of various root-only **ioctl(2)** commands for various PCI-based sound cards, such as Live! and Sound Blaster 512
- allows use of the experimental networking SIOCGIFDIVERT and SIOCSIFDIVERT Frame Diverter **ioctl(2)** commands
- allows the sending of the SCM_CREDENTIALS socket level control message, when the user ID of the credentials do not

- match the current process' effective, saved or current user ID value
- allows administration of md devices (Multiple Devices - RAID and LVM)
- allows adding and removing a Digital Video Broadcasting interface
- allows the VIDIOC_S_FBUF **ioctl(2)** command for the Philips saa7134-based TV card video4linux device driver, if the CAP_SYS_RAWIO capability is not enabled
- allows the use of the VIDIOCSFBUF and VIDIOC_S_FBUF **ioctl(2)** commands in the bttv and Zoran video device drivers, if the CAP_SYS_RAWIO capability is not enabled
- allows the use of the VIDIOCSFBUF **ioctl(2)** command in the planb video device driver if the CAP_SYS_RAWIO capability is not enabled
- allows the use of the VIDIOCSFBUF **ioctl(2)** command in the stradis 4:2:2 mpeg decoder driver
- allows the use of the Intelligent Input/Output (I2O) **ioctl(2)** commands
- allows manufacturer commands in ISDN CAPI support driver
- allows reading up to 256 bytes (non-standardized portions) of PCI bus configuration space, and also allows use of the **pciconfig_read(2)** and **pciconfig_write(2)** system service calls
- allows use of the root-only pcmcia **ioctl(2)** commands
- allows use of the FSACTL_SEND_RAW_SRB **ioctl(2)** command in the aacraid Adaptec RAID driver
- allows read and write to the QLogic ISP2x00 nvram
- allows access to the MegaRAID **ioctl(2)** commands
- allows use of the MTSETDRVBUFFER SCSI tape driver **ioctl(2)** command
- allows write access to the **/proc** SCSI debug file, if SCSI_DEBUG is enabled in the kernel (also requires the CAP_SYS_RAWIO capability)
- allows the sending of arbitrary SCSI commands via the SCSI_IOCTL_SEND_COMMAND **ioctl(2)** command (also requires the CAP_SYS_RAWIO capability)
- allows use of the SCSI scatter-gather SG_SCSI_RESET **ioctl(2)** command, **/proc/sg/allow_dio** and **/proc/sg/def_reserved_size write(2)**, (also requires the CAP_SYS_ADMIN capability)
- allows use of the IXICTL_TESTRAM and IXICTL_HZ **ioctl(2)** commands for the Quicknet Technologies Telephony card driver
- allows some autofs root-only **ioctls**
- allows getting and setting the extended attributes of filesystem objects (**getfattr(1)**, **setfattr(1)**)
- allows root-only **ioctl(2)** commands for NetWare Core Protocol (NCP) filesystems
- allows setting up a new smb filesystem connection

- allows the UDF_RELOCATE_BLOCKS **ioctl(2)** command on udf filesystems (used on some CD-ROMs and DVDs)
- allows administration of the random device
- allows binding of a raw character device (**/dev/raw/rawn**) to a block device
- allows configuring the kernel's syslog (printk behavior)
- allows writes to the **/proc/driver/btp/unit#/vme-mappings** file, if SBSVME is enabled in the kernel, to create and remove PCI-to-VMEbus mappings
- allows writes to **/proc/driver/graphics-memory** to modify size of the pre-allocated graphics memory pool

CAP_SYS_BOOT This capability allows use of the **reboot(2)** system service call.

CAP_SYS_CHROOT

This capability allows use of the **chroot(2)** system service call.

CAP_SYS_MODULE

This capability allows the insertion and deletion of kernel modules using **sys_delete_module(2)**, **init_module(2)**, **rmmod(8)** and **insmod(8)**.

This capability also lets you modify the kernel capabilities bounding set value, **cap_bset**, where this value is accessible via the **sysctl(2)** **kernel.cap-bound** parameter.

CAP_SYS_NICE This capability allows:

- raising the scheduling priority on processes with the same user ID
- setting the priority on other processes with a different user ID
- setting the SCHED_FIFO and SCHED_RR scheduling policies for processes that have the same user ID
- changing the scheduling policy of processes with a different user ID
- changing the cpu affinity for processes with a different user ID via the **sched_setaffinity(2)** or **/proc/pid/affinity** file
- allows the use of **fbsconfigure(3)**

CAP_SYS_PACCT This capability allows configuration of process accounting through the **acct(2)** system service call.

CAP_SYS_PTRACE

This capability lets a process **ptrace(2)** any other process.

This capability also allows the process to **ptrace(2)** setuid executables, regardless of the CAP_SETUID setting.

CAP_SYS_RAWIO This capability allows the following raw I/O activities:

- the **shmctl(2)** SHM_PHYSBIND command
- the **resched_cntl(2)** RESCHED_SET_VARIABLE command
- **mmap(2)** of PCI Bus space and access to the PCI Base Address Registers (BAR)

- **open(2)** of **/dev/port** and **/proc/kcore**
- use of the **ioperm(2)** and **iopl(2)** system service calls
- the filesystem **ioctl(2)** FIBMAP command
- **open(2)** of the **/dev/cpu/microcode** file, if MICROCODE is enabled in the kernel
- the following Disk Array driver for HP SA 5xxx and 6xxx Controllers **ioctl(2)** commands: CCISS_PASSTHRU, CCISS_BIG_PASSTHRU, CCISS_DEREGDISK, CCISS_REGNEWD
- the **open(2)** of Disk Array driver for Compaq SMART2 Controllers, and the IDAPASSTHRU **ioctl(2)** command
- the configuration of IDE controllers, and the following IDE **ioctl(2)** commands: HDIO_DRIVE_TASKFILE, HDIO_DRIVE_CMD, HDIO_DRIVE_TASK, HDIO_SCAN_HWIF, HDIO_UNREGISTER_HWIF
- the Fibre Channel Host Bus Adapter CPQFCTS_SCSI_PASSTHRU **ioctl(2)** command
- write access to the **/proc** SCSI debug file, if SCSI_DEBUG is enabled in the kernel (CAP_SYS_ADMIN is also required)
- sending of arbitrary SCSI commands via the SCSI_IOCTL_SEND_COMMAND **ioctl(2)** command (CAP_SYS_ADMIN is also required)
- use of the SCSI scatter-gather SG_SCSI_RESET **ioctl(2)** command, **/proc/sg/allow_dio** and **/proc/sg/def_reserved_size write(2)** (also requires the CAP_SYS_ADMIN capability)
- the ATMSIGD_CTRL **ioctl(2)** command
- use of the VIDIOC_SFBUF and VIDIOC_S_FBUF **ioctl(2)** commands in the bttv and Zoran video device drivers, if the CAP_SYS_ADMIN capability is not enabled
- use of the VIDIOC_SFBUF **ioctl(2)** command in the planb video device driver if the CAP_SYS_ADMIN capability is not enabled
- use of the HDLCDRVCTL_SETMODEMPAR and HDLCDRVCTL_CALIBRATE **ioctl(2)** commands in the baycom epp radio and HDLC packet radio network device drivers
- the SIOCSCCFG, SIOCSCCINI, SIOCSCSMEM, and SIOCSCCCAL **ioctl(2)** commands in the Z8530 based HDLC cards for AX.25 device driver
- the SIOCYAMSCFG **ioctl(2)** command in the AM radio modem device driver
- the COSAIOSTRT, COSAIODOWNLD, COSAIORMEM and COSAIOBMSET **ioctl(2)** commands for the SRP and COSA synchronous serial card device driver
- the FBIO_ALLOC and FBIO_FREE **ioctl(2)** commands for the SiS frame buffer device driver
- the VIDIOC_S_FBUF **ioctl(2)** command for the Philips saa7134-based TV card video4linux device driver, if the CAP_SYS_ADMIN capability is not enabled

CAP_SYS_RESOURCE

This capability lets the user:

- override disk quota limits
- override the IPC message queue size limit on a **msgctl(2)** **IPC_SET** command
- override the number of processes per process on **fork(2)**/**clone(2)** calls, when the non-root user does not have the **CAP_SYS_ADMIN** capability
- increase this user's resource limits with the **setrlimit(2)** system service
- set the real-time clock (rtc) periodic IRQ rate, or enable the periodic IRQ interrupts for a frequency that is greater than 64Hz
- override the limit on the number of console terminal opens/allocations
- override the limit on the number of console keyboard keymaps
- when allocating additional space on ufs, ext2 and ext3 filesystems, override the limit on the amount of reserved space. **Note:** the ext2 filesystem also honors the files system user ID when checking for resource overrides, allowing override using **setfsuid(2)** also.
- on ext3 filesystems, modify data journaling mode

CAP_SYS_TIME This capability allows:

- setting or adjusting the time via **clock_gettime(2)**, **stime(2)**, **settimeofday(2)** and **adjtimex(2)**
- use of the **RTC_SET_TIME** and **RTC_EPOCH_SET** **ioctl(2)** commands for the **/dev/rtc** real-time clock device

CAP_SYS_TTY_CONFIG

This capability allows:

- use of the **vhangup(2)** system service
- use of all the console terminal and keyboard **ioctl(2)** commands, including cases when the user is not the owner of the console terminal

Note that the use of the **KDKBDREP**, **KDSETKEYCODE**, **VT_LOCKSWITCH** and **VT_UNLOCKSWITCH** console terminal and keyboard **ioctl(2)** commands require this capability even when the user is the owner of the console terminal.

Kernel Trace Events

This appendix lists the pre-defined kernel trace events that are included in the RedHawk Linux trace and debug kernels as well as methods for defining and logging custom events within kernel modules.

Refer to the *NightTrace RT User's Guide*, publication number 0890398, for a complete description of how to supply trace points in user-level code, capture trace data and display the results.

Pre-defined Kernel Trace Events

Table D-1 provides a list of all the kernel trace events that are pre-defined within the RedHawk Linux trace and debug kernels.

Table D-1 Pre-defined Kernel Trace Events

Type of Trace Event	Trace Event Name	Description
System Calls	SYSCALL_ENTRY	A system call was entered. (i386 systems only)
	SYSCALL_EXIT	A system call exited. (i386 systems only)
	SYSCALL32_ENTRY	A 32-bit system call was entered. (x86_64 systems only)
	SYSCALL32_EXIT	A 32-bit system call exited. (x86_64 systems only)
	SYSCALL64_ENTRY	A 64-bit system call was entered. (x86_64 systems only)
	SYSCALL64_EXIT	A 64-bit system call exited. (x86_64 systems only)
FBS	FBS_SYSCALL	An FBS system call was made. Possible types include: 0 - fbsop 1 - fbsctl 2 - fbsget 3 - pmctl 4 - pmop 5 - fbwait 6 - fbstrig 7 - fbsavail 8 - fbsdir
	FBS_OVERRUN	A process scheduled on FBS incurred an overrun.

Table D-1 Pre-defined Kernel Trace Events (Continued)

Type of Trace Event	Trace Event Name	Description
Traps	TRAP_ENTRY	A trap was entered.
	TRAP_EXIT	A trap exited.
Interrupts	IRQ_ENTRY	An IRQ handler was entered.
	IRQ_EXIT	An IRQ exited.
	SMP_CALL_FUNCTION	A function call was made via cross processor interrupt.
	REQUEST_IRQ	A dynamic IRQ assignment was made.
	SOFT_IRQ_ENTRY	A softirq handler was entered. Possible types include: 1 - conventional bottom-half 2 - real softirq 3 - tasklet action 4 - tasklet hi-action
	SOFT_IRQ_EXIT	A softirq handler exited.
Process Management	SCHEDCHANGE	The scheduler made a context switch.
	PROCESS	A process management function was performed. Possible types include: 1 - kernel thread created 2 - fork or clone 3 - exit 4 - wait 6 - wakeup
	PROCESS_NAME	Associates a process ID with a process name prior to a fork, clone, or exec.
	SIGNAL	A signal was sent to a task. Possible types include: 1 - signal ignored 2 - signal dropped 3 - signal queued 4 - signal delivered
File System	FILE_SYSTEM	A file system function was performed. Possible types include: 1 - wait for data buffer started 2 - wait for data buffer finished 3 - exec 4 - open 5 - close 6 - read 7 - write 8 - seek 9 - ioctl 10 - select 11 - poll

Table D-1 Pre-defined Kernel Trace Events (Continued)

Type of Trace Event	Trace Event Name	Description
Timers	TIMER	A timer function was performed. Possible types include: <ul style="list-style-type: none"> 1 - timer expired 2 - set_itimer() system call 3 - schedule_timeout() kernel routine
Work Queues	WORKQUEUE_THREAD	A work queue thread was created.
	WORKQUEUE_WORK	A work queue handler was executed.
Memory Management	MEMORY	A memory management function was performed. Possible types include: <ul style="list-style-type: none"> 1 - page allocation 2 - page freeing 3 - pages swapped in 4 - pages swapped out 5 - wait for page started 6 - wait for page finished
	GRAPHICS_PGALLOC	An additional graphics bind page was dynamically allocated.
Sockets	SOCKET	A socket function was performed. Possible types include: <ul style="list-style-type: none"> 1 - generic socket system call 2 - socket created 3 - data sent on socket 4 - data read from socket
IPC	IPC	A System V IPC function was performed. Possible types include: <ul style="list-style-type: none"> 1 - generic System V IPC call 2 - message queue created 3 - semaphore created 4 - shared memory segment created
Networking	NETWORK	A network function was performed. Possible types include: <ul style="list-style-type: none"> 1 - packet received 2 - packet transmitted
Custom Event	CUSTOM	This is a user-defined event. Note: For information on logging this event and dynamically creating other custom kernel trace events, refer to the section “User-defined Kernel Trace Events” below.

Table D-1 Pre-defined Kernel Trace Events (Continued)

Type of Trace Event	Trace Event Name	Description
Kernel Trace Management	BUFFER_START	This event marks the beginning of a trace buffer.
	BUFFER_END	This event marks the end of a trace buffer.
	PAUSE	Tracing was paused.
	RESUME	Tracing was resumed.
	EVENT_MASK	The tracing event mask was changed.
	EVENT_CREATED	A new trace event was dynamically created.
	EVENT_DESTROYED	A dynamically created trace event was destroyed.

User-defined Kernel Trace Events

There is a pre-defined “custom” kernel trace event that can be used for any user-defined purpose. The description for using this CUSTOM kernel trace event is described in the next section. Other user-defined events can be created dynamically using the calls described in the section “Dynamic Kernel Tracing” below.

Pre-defined CUSTOM Trace Event

TRACE_CUSTOM may be used to log the pre-defined CUSTOM trace event. The caller provides an integer identifier (*sub_id*) to differentiate multiple uses of the CUSTOM event. The caller may also provide any arbitrary string of data to be logged with the event.

Synopsis

```
#include <linux/trace.h>
void TRACE_CUSTOM (int sub_id, const void* ptr, int size);
```

Arguments are defined as follows:

sub_id a user-supplied ID
ptr a pointer to arbitrary data to be logged with the event
size the size of the data

Dynamic Kernel Tracing

In addition to the pre-defined CUSTOM kernel trace event described above, user-defined kernel trace events can be dynamically created. All are displayed by NightTrace RT for analysis.

For dynamic kernel tracing, the following calls are used, which are described below:

- **trace_create_event** – allocates an unused trace event ID and associates it with a given name
- **trace_destroy_event** – deallocates the event ID
- **TRACE_LOG_EVENT** – a generic trace point function that may be used to log a dynamic event

trace_create_event

This call allocates an unused trace event ID and associates it with the given name.

Synopsis

```
#include <linux/trace.h>
int trace_create_event (const char* name);
```

The argument is defined as follows:

name is a unique, user-defined name for the trace event. This name is truncated to 31 characters.

The event ID is returned. An attempt is made to return an ID that was not used (created and destroyed) recently. An `EVENT_CREATED` trace event is logged with this call.

On failure, one of the following is returned:

- ENOSPC All dynamic event IDs are in use.
- EINVAL The given name pointer is NULL or points to a NULL string.
- EEXIST The given name is non-unique.
- ENOMEM Memory allocation error.

trace_destroy_event

This call deallocates the trace event ID that was allocated with `create_trace_event`.

Synopsis

```
#include <linux/trace.h>
void trace_destroy_event (int id);
```

The argument is defined as follows:

id the event ID that was allocated with `create_trace_event`.

An `EVENT_DESTROYED` trace event is logged with this call.

TRACE_LOG_EVENT

This may be used to log a trace point for the newly-created dynamic trace event.

Synopsis

```
#include <linux/trace.h>
```

```
void TRACE_LOG_EVENT (int id, const void* ptr, int size);
```

Arguments are defined as follows:

<i>id</i>	the event ID
<i>ptr</i>	a pointer to arbitrary data to be logged with the event
<i>size</i>	the size of the data

Migrating 32-bit Code to 64-bit Code

This appendix provides information needed to migrate 32-bit code to 64-bit processing on x86_64 architectures.

Introduction

RedHawk Linux Version 2.X and later can execute on the 64-bit AMD Opteron and EM64T processors as well as on the 32-bit Intel Pentium Xeon processors. The x86_64 version of RedHawk Linux is a full 64-bit operating system that executes both 32-bit and 64-bit applications in native mode on the x86_64 processor.

The Opteron processor utilizes the AMD64 Instruction Set Architecture (ISA), which is nearly identical to recent Intel processors that support the EM64T ISA (e.g. all Intel Nocona processors). Both AMD64 and EM64T are capable of true 64-bit execution, and are collectively known as “x86_64” architectures.

The “long” execution mode of x86_64 processors has two submodes: “64-bit” and “compatibility.” Existing 32-bit application binaries can run without recompilation in compatibility mode under RedHawk Linux, or the applications can be recompiled to run in 64-bit mode.

32-bit applications run natively with no “emulation mode” to degrade performance. For this reason, many applications do not need to be ported to 64-bits.

NOTE

Real-time extensions and features are *not* available to 32-bit applications running under a 64-bit operating system (i.e. x86_64). In order to use real-time features, migrate 32-bit applications to 64-bit or boot a 32-bit operating system instead.

Software optimized for x86_64 can make use of the large addressable memory and 64-bit architectural enhancements required by the most demanding applications, such as scientific computing, database access, simulations, CAD tools, etc. If an application would benefit from the larger virtual and physical address space afforded by 64-bit processing, information in this section will help you migrate your code.

Porting existing 32-bit applications to 64-bits involves the following areas, which are discussed in detail in the sections that follow:

- Source code written for 32-bits will likely require modifications to execute in 64-bit mode.
- Binaries that have been compiled for 32-bit operation need to be recompiled for 64-bit before running in 64-bit mode.

- The build process (makefiles, project files, etc.) may need to be updated to build 64-bit executables and add portability checking options for compilation.
- Only 64-bit device drivers can be used with 64-bit operating systems. Applications that install device drivers may not work correctly if there is no 64-bit version of the required driver. All drivers supplied with RedHawk Linux are 64-bit compatible.

In addition, hints to get the most performance from your applications are provided.

The **AMD64 Developer Resource Kit** is a complete resource for programmers porting or developing applications and drivers for the Opteron processor. The AMD64 DRK contains technical information including documentation, white papers, detailed presentations and reference guides. This Kit is available from the www.amd.com web site.

Procedures

In order to systematically address modifying your code for porting to 64-bits, follow the guidelines below. All source files should be reviewed and modified accordingly, including header/include files, resource files and makefiles. Specifics regarding these steps are provided in the sections that follow.

- Use `#if defined __x86_64__` or `__amd64__` for code specific to AMD64 architecture.
- Convert all inline assembly code to use intrinsic functions or native assembly subroutines.
- Modify calling conventions in existing assembly code as needed.
- Review use of any pointer arithmetic and confirm results.
- Review references to pointers, integers and physical addresses and use the variable size data types to accommodate the differences between 32 and 64-bit architectures.
- Examine makefiles to build 64-bit executables and add portability checking options.

Coding Requirements

Data Type Sizes

The main issue with 32-bit and 64-bit portability is that there should be no presumption about the size of an address or its relationship to the size of an `int`, `long`, etc.

Table E-1 shows the sizes of the various ANSI data types under RedHawk Linux on AMD64 systems.

Table E-1 Sizes of Data Types

ANSI Data Type	Size in Bytes
<code>char</code>	1
<code>short</code>	2
<code>int</code>	4
<code>long</code>	8
<code>long long</code>	8
<code>intptr_t</code> , <code>uintptr_t</code>	8
<code>float</code>	4
<code>double</code>	8
<code>long double</code>	16

You can use the `sizeof` operator to get the size of the various data types; for example, if you have a variable `int x` you can get the size of `x` with `sizeof(x)`. This usage works even for structs or arrays. For example, if you have a variable of a struct type with the name `a_struct`, you can use `sizeof(a_struct)` to find out how much memory it is taking up.

Longs

Longs become 64-bit, therefore, you need to examine all direct or implied assignments or comparisons between `long` and `int` values. Examine all casts that allow the compiler to accept assignment and comparison between longs and integers to ensure validity. Use the value of the `BITS_PER_LONG` macro to determine the size of longs.

If ints and longs must remain different sizes (for example, due to existing public API definitions), implement an assertion that ascertains that the value of the 64-bit item does not exceed the maximum value of the 32-bit item and generate an exception condition to handle the case if it does occur.

Pointers

Pointers become 64-bit, therefore, you also need to examine all direct or implied assignments or comparisons between pointers and `int` values. Remove all casts that allow the compiler to accept assignment and comparison between pointers and integers. Change the type to a type of variable size (equal to pointer size). Table E-2 shows the variable size data types.

Table E-2 Variable Size Data Types

ANSI Data Type	Definition
<code>intptr_t</code>	Signed integral type to hold a pointer
<code>uintptr_t</code>	Unsigned integral type to hold a pointer
<code>ptrdiff_t</code>	Signed type to hold the signed difference of two pointer values
<code>size_t</code>	Unsigned value indicating the maximum number of bytes to which a pointer can refer
<code>ssize_t</code>	Signed value indicating the maximum number of bytes to which a pointer can refer

Arrays

Under 32-bit code, `int` and `long` could be used to hold the size of arrays. Under 64-bit, arrays can be longer than 4 GB. Instead of `int` or `long`, use the `size_t` data type for portability. It will become 64-bit signed integral type when compiled for 64-bit targets, or 32-bit for 32-bit targets. The return values from both `sizeof()` and `strlen()` are both of type `size_t`.

Declarations

You also need to alter any declarations of variables, parameters or function/method return types that must be changed to 64-bit to use one of the size variant types shown in Table E-2.

Explicit Data Sizes

When it is necessary to explicitly address data size, use the data types in Table E-3. There are no ANSI data types that specifically address data size; these types are specific to Linux.

Table E-3 Fixed Precision Data Types

Data Type	Definition
<code>int64_t</code>	64-bit signed integer
<code>uint64_t</code>	64-bit unsigned integer
<code>int32_t</code>	32-bit signed integer
<code>uint32_t</code>	32-bit unsigned integer
<code>int16_t</code>	16-bit signed integer
<code>uint16_t</code>	16-bit unsigned integer
<code>int8_t</code>	8-bit signed integer
<code>uint8_t</code>	8-bit unsigned integer

Constants

Constants, especially hex or binary values, are likely to be 32-bit specific. For example, a 32-bit constant 0x80000000 becomes 0x0000000080000000 in 64-bit. Depending upon how it is being used, the results may be undesirable. Make good use of the ~ operator and type suffixes to avoid this problem; for example, the 0x80000000 constant might be better as ~0x7fffffff instead.

APIs

Code might need to be changed to use 64-bit APIs. Some APIs use data types which the compiler will interpret as 64-bit in conflict with explicit 32-bit data types.

Calling Conventions

Calling conventions specify how processor registers are used by function callers and callees. This applies when porting hand coded assembly code that interoperates with C code and for in-line assembly statements. The Linux calling conventions for the x86_64 are given in Table E-4.

Table E-4 Calling Conventions

Register	Status	Use
%rax	Volatile	Temporary register; with variable arguments passes information about the number of SSE registers used; first return register
%rbx	Non-volatile	Optionally used as base pointer, must be preserved by callee
%rdi, %rsi, %rdx, %rcx, %r8, %r9	Volatile	Used to pass integer arguments 1,2,3,4,5,6
%rsp	Non-volatile	Stack pointer
\$rbp	Non-volatile	Optionally used as frame pointer, must be preserved by callee
%r10	Volatile	Temporary register, used for passing a function's static chain pointer
%r11	Volatile	Temporary register
%r12-%r15	Non-volatile	Must be preserved by callee
%xmm0-%xmm1	Volatile	Used to pass and return floating point arguments
%xmm2-%xmm7	Volatile	Used to pass floating point arguments
%xmm8-%xmm15	Volatile	Temporary registers
%mmx0-%mmx7	Volatile	Temporary registers
%st0	Volatile	Temporary register; used to return long double arguments
%st1-%st7	Volatile	Temporary registers
%fs	Volatile	Reserved for system use as thread-specific data register

Conditional Compilation

In cases where there is the need to supply conditional code for 32-bit vs. 64-bit execution, the macros in Table E-5 can be used.

Table E-5 Macros for Conditional Compilation

Macro	Definition
<code>__amd64__</code>	Compiler will generate code for AMD64
<code>__i386</code>	Compiler will generate code for x86

Miscellaneous

A variety of other issues can arise from sign extension, memory allocation sizes, shift counts, and array offsets. Be especially careful about any code that makes assumptions about the semantics of integer overflow.

Compiling

Existing makefiles should build native 64-bit executables on the x86_64 processor with little or no modifications.

The following `gcc` switches can be used to catch portability issues. Refer to the `gcc(1)` man page for details.

```
-Werror -Wall -W -Wstrict-prototypes -Wmissing-prototypes  
-Wpointer-arith -Wreturn-type -Wcast-qual -Wwrite-strings  
-Wswitch -Wshadow -Wcast-align -Wuninitialized -ansi  
-pedantic -Wbad-function-cast -Wchar-subscripts -Winline  
-Wnested-externs -Wredundant-decl
```

Testing/Debugging

Follow standard RedHawk Linux testing and debugging techniques for 64-bit code.

Performance Issues

The information in this section discusses how to get the best performance from your 64-bit application.

Memory Alignment and Structure Padding

Alignment issues won't cause exceptions but can cause a performance hit. Misalignment is handled at runtime at the expense of several clock cycles. The performance side-effects of poorly aligned operands can be large.

Data within structures will be aligned on natural boundaries which can lead to inefficient code due to wasted space. Natural alignment means that 2-byte objects are stored on 2-byte boundaries, 4-byte objects on 4-byte boundaries, etc.

For example, the following structure definition will consume 24 bytes when generating 64-bit code:

```
typedef struct _s {
    int x;
    int *p;
    int z;
} s, *ps;
```

The pointer `p` will be aligned on an 8-byte boundary which will cause 4 bytes of padding to be added after the `x` member. In addition, there will be an additional 4 bytes of padding after the `z` member to pad the structure out to an even eight byte boundary.

The most efficient structure packing will be achieved by placing the members from largest to smallest in the structure. The following declaration is more efficient. It will take only 16 bytes and does not require any padding:

```
typedef struct _s }
    int *p;
    int x;
    int z;
} s;
```

Because of potential padding, the safest way to find the constant offset of fields within a structure is to use the `offsetof()` macro, which is defined in `stddef.h`.

Kernel-level Daemons on Shielded CPUs

The Linux kernel uses many kernel daemons to perform system functions. Some of these daemons are replicated on every CPU in the system. Shielding a CPU from processes will not remove one of these “per-CPU” daemons.

The following daemons can create serious jitter problems on process-shielded CPUs. Fortunately, these daemons can be avoided by configuring and using the system carefully.

`kmodule` *cpu* These daemons are created and executed each time a kernel module is unloaded. It is highly recommended that kernel modules are not unloaded while real-time applications are running on the system.

`migration`/*cpu* These are the task migration daemons responsible for migrating tasks off a particular CPU. These daemons will run on a process-shielded CPU if a process running on that CPU is forced to migrate off that processor. Forced migration may happen when any of the following interfaces are used:

```
/proc/pid/affinity
sched_setaffinity(2)
/proc/shield/procs
cpucntl(2)
delete_module(2)
```

Applications that are running on shielded CPUs should use these interfaces only when background process jitter can be tolerated.

Forced migration is also done by various kernel features, which can be enabled with the CPU_FREQ and NUMA kernel configuration options. These options have been disabled by default in all RedHawk Linux kernel configurations.

`kswapd`*node* These are the page swap-out daemons that swap pages out to a swap device to reclaim pages when memory runs low.

When the kernel is built with the NUMA configuration option enabled, there may be several of these daemons, each biased to a single CPU. When a CPU is process-shielded or downed (using **`cpu(1)`**), the daemon is moved to a non-shielded active CPU. When the CPU is no longer shielded or down, the daemon is moved back.

When NUMA is disabled, there is one system-wide daemon that is not biased to any particular CPUs; therefore, **`kswapd`** will not run on CPUs shielded from processes and is only a problem on a non-shielded CPU.

NUMA is enabled by default only on prebuilt RedHawk x86_64 kernels.

kapmd This is the Advanced Power Management (APM) daemon that processes power management requests. It is always biased to CPU 0. APM may be disabled with the kernel boot parameter "apm=off" or may be completely eliminated by disabling the APM kernel configuration option. APM has been disabled by default in all RedHawk Linux kernel configurations. Because this daemon is not a per-CPU daemon, it will not run on CPUs shielded from processes and is therefore a problem only on a non-shielded CPU.

The following daemons may execute on process-shielded CPUs. However, because they perform necessary functions on behalf of processes or interrupts that have been biased to that CPU, and because these daemons are only activated as a result of actions initiated by the processes or interrupts that are biased to a shielded CPU, these daemons are considered less problematic in terms of their impact on determinism.

ksoftirqd/cpu These are the softirq daemons that execute softirq routines for a particular CPU. One of these daemons will run on a process-shielded CPU if a device driver interrupt handler biased to that CPU uses softirqs either directly or indirectly via tasklets. Softirqs are used directly by the local timer, SCSI, and networking interrupt handlers. Tasklets are used by many device drivers.

The priority of the **ksoftirqd** is determined by the `SOFTIRQ_PRI` kernel tunable, which is located under General Setup on the Kernel Configuration GUI. When `SOFTIRQ_PRI` is set to a positive number, that number is the priority at which **ksoftirqd** will run. By default, this tunable is set to zero, and the setting of `SOFTIRQ_PREEMPT_BLOCK` affects the daemon's priority. When set to Y, the **ksoftirqd** daemon will run as under the `SCHED_FIFO` scheduling policy at a priority of one less than the highest real-time priority. When set to N, the **ksoftirqd** daemon will run at priority zero.

events/cpu These are the default work queue threads that perform work on behalf of various kernel services initiated by processes on a particular CPU. They also may perform work that has been deferred by device driver interrupt routines that have been biased to the same CPU. These daemons execute with a nice value of -10.

aio/cpu These are work queue threads that complete asynchronous I/O requests initiated with the `io_submit(2)` system call by processes on a particular CPU. These daemons execute with a nice value of -10.

reiserfs/cpu These are work queue threads used by the Reiser File System. These daemons execute with a nice value of -10.

xfsdatad/cpu
xfslogd/cpu These are work queue threads used by the IRIX Journaling File System (XFS). These daemons execute with a nice value of -10.

cio/*cpu*

kblockd/*cpu*

wanpipe_wq/*cpu*

These are work queue threads used by various device drivers. These threads perform work on behalf of various kernel services initiated by processes on a particular CPU. They also perform work that has been deferred by device driver interrupt routines that have been biased to the same CPU. These daemons execute with a nice value of -10.

Note also that any third-party driver may create private work queues and work queue threads that are triggered by processes or interrupt handlers biased to a shielded CPU. These daemons are always named *name/cpu* and execute with a nice value of -10.

Cross Processor Interrupts on Shielded CPUs

This appendix discusses the impact of cross processor interrupts on shielded CPUs and methods to reduce or eliminate these interrupts for best performance.

Overview

On a RedHawk platform configured with one or more shielded CPUs, certain activities on the other CPUs can cause interrupts to be sent to the shielded CPUs. These cross processor interrupts are used as a method for forcing another CPU to handle some per-CPU specific task, such as flushing its own data cache or flushing its own translation look-aside buffer (TLB) cache.

Since cross processor interrupts can potentially cause noticeable jitter for shielded CPUs, it is useful to understand the activities that cause these interrupts to occur, and also how to configure your system so that some of these interrupts can be eliminated.

Memory Type Range Register (MTRR) Interrupts

On Intel P6 family processors (Pentium Pro, Pentium II and later) the Memory Type Range Registers (MTRRs) can be used to control processor access to memory ranges. This is most useful when you have a video (VGA) card on a PCI or AGP bus. Enabling write-combining allows bus write transfers to be combined into a larger transfer before bursting over the PCI/AGP bus. This can increase performance of image write operations by 2.5 times or more.

The NVIDIA device driver contained in RedHawk kernels will make use of the CPU's Page Attribute Table (PAT) registers instead of the MTRR registers if the PAT registers are supported by the processors in the system. Only when the system's processors do not contain PAT support will the NVIDIA driver fall back to using the MTRR registers. Therefore, for most systems, the issues described below concerning MTRR related cross processor interrupt do *not* apply.

While the MTRRs provide a useful performance benefit, whenever a new MTRR range is set up or removed, a cross processor interrupt will be sent to all the other CPUs in order to have each CPU modify their per-CPU MTRR registers accordingly. The time that it takes to process this particular interrupt can be quite lengthy, since all the CPUs in the system must first sync-up/handshake before they modify their respective MTRR registers, and they must handshake yet again before they exit their respective interrupt routines. This

class of cross processor interrupt can have a severe effect on determinism having been measured at up to three milliseconds per interrupt.

When the X server is first started up after system boot, a MTRR range is set up, and one of these MTRR cross processor interrupts is sent to all other CPUs in the system. Similarly, when the X server exits, this MTRR range is removed, and all other CPUs in the system receive yet another MTRR interrupt.

Three methods can be used to eliminate MTRR related cross processor interrupts during time-critical application execution on shielded CPUs:

1. Reconfigure the kernel so that the MTRR kernel configuration option is disabled. When using the Kernel Configuration GUI, this option is located under the **Processor Type and Features** section and is referred to as “MTRR (Memory Type Range Register) support”. This eliminates MTRR cross processor interrupts since the kernel support for this feature is no longer present. Note that this option has a potentially severe performance penalty for graphic I/O operations.
2. Start up the X server before running the time-critical applications on the shielded CPU(s), and keep the X server running until the time-critical activity has completed. The MTRR interrupts will still occur, but not during time-critical activities.
3. The MTRR range can be preconfigured so that no cross processor interrupts occur. Use the following procedure for preconfiguration of the MTRRs used by the X server:
 - a. After the system is booted, but before the X server has started up, examine the current MTRR settings. You need to be in either init state 1 or 3.

```
cat /proc/mtrr
reg00: base=0x00000000 ( 0MB), size=1024MB: write-back, count=1
reg01: base=0xe8000000 (3712MB), size= 128MB: write-combining, count=1
```

- b. After the X server is started up, re-examine the MTRR register settings:

```
cat /proc/mtrr
reg00: base=0x00000000 ( 0MB), size=1024MB: write-back, count=1
reg01: base=0xe8000000 (3712MB), size= 128MB: write-combining, count=2
reg02: base=0xf0000000 (3840MB), size= 128MB: write-combining, count=1
```

- c. In this example, the new X server entry is the last entry, “reg02”. If your system has multiple graphics cards, or shows more than one new entry, then these additional entries should also be accommodated with additional **rc.local** script entries.
 - d. Now add additional line(s) to your **/etc/rc.d/rc.local** script to account for the X server MTRR entries. In our example we have just one X server entry to account for:

```
echo "base=0xf0000000 size=0x8000000 type=write-combining" > /proc/mtrr
```

- e. Whenever the hardware configuration is modified on the system, it is a good idea to check that the MTRR entries in **/etc/rc.d/rc.local** are still correct by starting up the X server and using:

```
cat /proc/mtrr
```

to examine the MTRR output and check for differences from the previous MTRR settings.

Graphics Interrupts

A number of cross processor interrupts are issued while running graphics applications.

A kernel graphics driver such as the NVIDIA driver will allocate and setup various cache-inhibited graphics memory buffers for writing and reading data to and from the NVIDIA graphics processing unit (GPU).

Whenever these buffers are added or removed during graphics execution, cross processor interrupts are sent to each of the other CPUs in the system in order to have them flush their data and translation lookaside buffer (TLB) caches for these types of buffer cache-mode transitions. These types of cross processor interrupts can have a fairly severe impact that has been measured to be from 50 to 250 microseconds per interrupt. Cache-inhibited kernel graphics buffer allocations and deallocations occur when:

- starting up or exiting the X server
- running graphics applications
- switching from a non-graphics tty back to the graphics screen with a Ctrl Alt F# keyboard sequence

For systems with NVIDIA PCIe and/or PCI graphics card(s), these types of cross processor interrupts may be eliminated or reduced when a pool of cache-inhibited buffer pages is pre-allocated. As graphics buffer allocations are made, the pages needed to satisfy these requests are taken from the pre-allocated freelist of pages. Since these pages are already cache-inhibited, there is no need to issue additional flush operations when these pages are used. When a buffer allocation is removed, the pages are placed back onto the page freelist, thus remaining cache-inhibit clean. Should the pool of pre-allocated pages be empty when a request is made, pages will be dynamically allocated and cross processor interrupts will be issued in the normal fashion. Therefore, it is usually best to pre-allocate enough pages so that the pool of available pages never becomes empty.

To enable this support, the `PREALLOC_GRAPHICS_PAGES` kernel parameter must have a positive value representing the number of pre-allocated pages in the pool. A value of 10240 is configured into all pre-built RedHawk Linux kernels.

To disable this support, you may use a pre-built RedHawk Linux kernel and specify the “`no_pregraph_pgs`” grub line kernel parameter, or you may build a custom kernel and specify a a value of 0 (zero) for the `PREALLOC_GRAPHICS_PAGES` kernel parameter. This support is always disabled on systems where no NVIDIA PCI/PCIe graphics cards are present, regardless of the `PREALLOC_GRAPHICS_PAGES` parameter value.

The `PREALLOC_GRAPHICS_PAGES` option is located under the **Device Drivers -> Graphics Support** subsection of the Kernel Configuration GUI.

The `/proc/driver/graphics-memory` file can be examined while running graphics applications to observe the maximum amount of graphics memory pages actually in use at any time. For example:

```
$ cat /proc/driver/graphics-memory
Pre-allocated graphics memory:      10240 pages
Total allocated graphics memory:    10240 pages
Graphics memory in use:             42 pages
Maximum graphics memory used:       42 pages
```

You may write to the file to increase or decrease the number of pages in the pool. This allows you to test your system with various values before changing the kernel configuration parameter. The following example lowers the number of pre-allocated pages in the pool to 5120:

```
$ echo 5120 > /proc/driver/graphics-memory
```

The user must have CAP_SYS_ADMIN capability to write to this file. Note that the page value written to the file must be larger than or equal to the current value of the “Graphics memory in use” field. If the number of currently allocated pages needs to be lowered, exit the X server.

Specifying an unrealistically large value will result in page allocation failures and the allocation will be backed out. After writing to the file, read the file to verify that the page allocation change was successful.

Note that on some systems, when the NVIDIA driver is loaded or unloaded, a Page Attribute Table (PAT) cross processor interrupt is sent to each CPU. To minimize the jitter involved, avoid loading or unloading the NVIDIA module during time-critical applications. You may pre-load the NVIDIA driver before running time-critical applications, or during system boot with the following command:

```
$ modprobe nvidia
```

NVIDIA CUDA Interrupts

NVIDIA CUDA is a general purpose parallel computing architecture that makes use of the parallel compute engine that is present in NVIDIA graphics processing units (GPUs) to solve many complex computational problems in a fraction of the time required on a CPU.

Since CUDA applications make use of cache-inhibited buffers to interface with the NVIDIA GPU(s), the same preallocated graphics buffer support mentioned in the previous section will also help to greatly reduce jitter on shielded CPUs in a system where CUDA applications are being executed.

Use of the preallocated graphics buffers by CUDA applications will automatically occur as long as there are free preallocated buffers in the pool; no special CUDA application coding or configuration is required.

User Address Space TLB Flush Interrupts

Processes that are biased to execute on a shielded CPU and that share their address space with processes that execute on other CPUs may receive user-space TLB flush cross processor interrupts. Processes that make use of shared memory areas but which are sharing their address space only with processes on the same CPU will *not* observe any cross processor interrupts due to any shared memory activity.

Multithreaded applications that use the pthreads library and Ada applications are examples of shared memory applications – even though the programmer has not explicitly made calls to create shared memory. In these types of programs, the pthreads library and the Ada run time are creating shared memory regions for the user. Therefore, these applications are subject to this type of cross processor interrupt when threads from the same thread group or same Ada program execute on separate CPUs in the system.

A user address TLB flush cross processor interrupt is generated when another process that is sharing the same address space is executing on a different CPU and causes a modification to that address space's attributes. Activities such as memory references that cause page faults, page swapping, `mprotect()` calls, creating or destroying shared memory regions, etc., are examples of address space attribute modifications that can cause this type of cross processor interrupt. This class of cross processor interrupt has minimal impact that has been measured at less than 10 microseconds per interrupt. When large amounts of memory are shared, the impact can be more severe.

In order to eliminate these types of cross processor interrupts, users are encouraged to use and write their applications such that time-critical processes executing on shielded CPUs avoid operations which would affect a shared memory region during the time-critical portion of their application. This can be accomplished by locking pages in memory, not changing the memory protection via `mprotect()` and not creating new shared memory regions or destroying existing shared memory regions.

H

Serial Console Setup

This appendix provides the steps needed to configure a serial console under RedHawk Linux.

Note that a serial console is needed if you wish to use the **kdb** kernel debugger on a system with a USB keyboard.

1. Modify the boot command line to include the following kernel option:

```
console=tty#,baud#
```

where `tty#` is the serial port to use for the console and `baud#` is the serial baud rate to use. Generally, this almost always looks like:

```
console=ttyS0,115200
```

2. Change the `/etc/inittab` file to include the following line:

```
S0:2345:respawn:/sbin/agetty 115200 ttyS0 vt100
```

The `baud#` and `tty#` must match the same values that were given in the boot option in step 1. The final keyword specifies the terminal type, which is almost always `vt100` but can be customized if necessary. See the **agetty(8)** man page for more information.

This line can be added anywhere in the file, although it is generally added at the end. The purpose of this line is to get a login on the serial console after the system boots into multi-user mode.

3. If root login is desired on the serial console (generally it is) you must change or remove the `/etc/securetty` file. See the **securetty(5)** man page for more details.
4. Connect a suitable data terminal device to the serial port and ensure that it is configured to communicate at the chosen baud rate. Depending on the specific device being used, a null-modem may be required.

Note that an inexpensive Linux PC is an excellent choice for a data terminal device. See the **minicom(1)** man page for more information about creating a serial communication session.

A Windows PC can also be used, but the explanation of that is beyond the scope of this documentation.

Another use for a serial console is to configure a real time shell to examine a system that is likely to hang. This procedure should be completed on the configured serial console before starting any application load that is experiencing problems.

1. Configure a serial console on a system that is likely to hang. For example:

- Add this string to your grub boot command line:

```
console=ttyS0,115200
```

- Add this line to your **/etc/inittab** file:
S0:2345:respawn:/sbin/agetty 115200 ttyS0 vt100
 - Add a "ttyS0" entry to the **/etc/securetty** file.
 - Connect a serial cable to your lowest numbered serial port and to the serial port of another computer or laptop.
2. If the other computer is Linux:
- Open a shell.
 - # **minicom -s**.
 - Use <CR>'s to get to the Serial Port Setup.
 - Change device to **/dev/ttyS0**.
 - Change baud to 115200.
 - Exit (Do not "Exit Minicom").
 - From the login prompt, login as root.

If the other computer is Windows:

- Bring up the Hyperterm application.
 - Connect using COM 1.
 - Set the baud rate to 115200.
 - From the login prompt, login as root.
3. From the root login, run the **RTConsole.sh** script shown below. As an argument, give it a higher real time priority than any of your tasks. For example:

```
# ./RTConsole.sh 90
```

This procedure provides a login shell which should remain active during a 'hang' and give you access and visibility into the system for debugging. A good start would be to run **top(1)** to determine which process is dominating the system.

When debugging is finished the system should be rebooted:

```
# reboot
```

RTConsole.sh

```
#!/bin/bash
if [ $UID -ne 0 ]
then
    echo "Must be root to execute."
    exit
fi

if [ $# -eq 0 ]
then
    echo "Usage: RTConsole <Login shell priority>"
    exit
fi

for i in $(ps -e -o pid,cmd | fgrep /0 | fgrep -v fgrep | awk '{print $1}');
do
    run -s fifo -P $1 -p $i
done
run -s fifo -P $1 -p $$PPID
```

Boot Command Line Parameters

Table I-1 lists boot command line parameters that operate uniquely to RedHawk. It does not include all boot command line parameters available under Linux. For that list, refer to the file **Documentation/kernel-parameters.txt** in your kernel source directory or type **info grub**.

Boot parameters define functionality that is built into a kernel. The boot commands can be added to **/etc/grub.conf** for automatic inclusion when the kernel boots, or specified on the boot command line when booting the kernel.

Information about individual features is available in various locations. In Table I-1, the following references are provided:

- Page numbers (active hypertext links) where information included in this *RedHawk Linux User's Guide* is provided
- Names and publication numbers of other appropriate Concurrent documents

Other sources where information may be obtained include:

- Files under the **Documentation** directory of the kernel source tree
- Linux documentation sites on the Internet

Table I-1 Boot Command Line Parameters

Parameter	Options	Description	Concurrent Documentation Reference
crashkernel	=size@16M	Reserves memory and non-default location for loading a “crash” kernel containing the core image of a corrupt kernel for purposes of saving and analyzing a crash dump. size is the size of reserved memory: 32M, 64M (default) or 128M 16M is the offset address	page 12-1
kdb	=on	Enables entry to the kdb kernel debugger.	page 12-8
	=off	Disables entry to kdb.	/kernel-source/ Documentation/kdb
	=early	Makes the kernel enter kdb early in the boot process.	
memmap	=size<delimiter>address	Defines memory regions to be reserved. <delimiter> is ‘@’ for System RAM, ‘\$’ for Reserve or “#” for ACPI.	page 2-22
	=exactmap	Specifies that the exact BIOS map is used.	
mm	=size<delimiter>address	Alias for memmap (x86_64 only). Defines memory regions to be reserved.	page 2-22
	=ex	Alias for exactmap (x86_64 only). Specifies that the exact BIOS map is used.	
nmi_dump		Enables pressing the system NMI button to enter the debugger. Exiting the debugger loads the crash kernel and takes a dump, unless nmi_watchdog=0.	page 12-9

Table I-1 Boot Command Line Parameters (Continued)

Parameter	Options	Description	Concurrent Documentation Reference
nmi_watchdog	=0	Turns the NMI watchdog feature off. Default setting on RedHawk kernels.	page 12-9 <i>/kernel-source/Documentation/nmi_watchdog.txt</i>
	=1	Each CPU performs its own NMI timing. Requires APIC support in the kernel. Currently this setting does not work and is changed to =2.	
	=2	Uses external NMI timer; generated interrupts are sent to all CPUs via broadcast. Default setting for i386 debug kernel.	
	=-1	Kernel selects values 1 or 2. x86_64 only. Default setting for x86_64 debug kernel.	
no-hz	=yes	Includes the NO_HZ kernel code if NO_HZ and NO_HZ_ENABLED are configured in the kernel.	page B-1
	=no	Disables the NO_HZ kernel code if NO_HZ and NO_HZ_ENABLED are configured in the kernel.	
noirqbalance	n/a	Can be used to turn IRQ balancing off if the kernel tunable IRQBALANCE is enabled in the kernel. The default is not enabled (recommended for shielded CPUs). Not enabled/off prevents periodic adjustments of IRQ affinities for balancing the interrupt load across CPUs.	page 2-10
no_pregraph_pgs	n/a	Disables all of the preallocated graphics pages support, which is used to minimize cross processor interrupts.	page 10-5
numa	=off	Disables NUMA support on an x86_64 system with the kernel tunable NUMA enabled in the kernel. This will create a system with a single NUMA node, with all CPUs belonging to that node. This differs from not having NUMA support built into the kernel, in which there is a flat memory system with no nodes and NUMA user interfaces return errors when called.	page 10-1

Table I-1 Boot Command Line Parameters (Continued)

Parameter	Options	Description	Concurrent Documentation Reference
prefer_highmem	n/a	Disables the use of the local NUMA node's "normal zone" pages before selecting a remote NUMA node's "highmem zone" pages (when the local NUMA node's highmem zone pages have already been fully allocated).	page 10-15
rcim	= <i>rcimoptions</i>	Defines configuration options for the RCIM, such as interrupt characteristics and associations, timing sources and RCIM master hostname.	RCIM User's Guide (0898007)
rhash_entries	= <i>n</i>	Sizes the IP route cache table, flushed periodically by ksoftirqd, to a fixed number of entries. By default, the size is based dynamically on the amount of available memory. Use this entry to define a smaller size to reduce excessive ksoftirqd runs.	page 2-34
tsc_sync	=auto	Check if the BIOS synced the TSCs correctly. If not, re-sync the TSCs. This is the default.	page 7-1
	=check	Only check if the BIOS synced the TSCs correctly. If the BIOS failed, disable TSCs as a possible clocksource.	
	=force	Re-sync all the TSCs at the end of boot unconditionally.	
vmalloc	= <i>nm</i> [KMG]	The size of the total vmalloc allocation area. Increasing this value also increases the large vmalloc area unless vmalloc_sm is used to increase the small vmalloc area. These two boot parameters may be used either together or independently. K, M or G can be used to specify size units: kilobytes, megabytes or gigabytes, respectively.	page G-5
vmalloc_sm	= <i>nm</i> [KMG]	The size in bytes of the small vmalloc allocation area. See vmalloc above.	page G-5

Glossary

This glossary defines terms used in RedHawk Linux. Terms in *italics* are also defined here.

affinity

An association between processes or interrupts and the CPUs on which they are allowed to execute. They are prohibited from executing on CPUs not included in their affinity mask. If more than one CPU is included in the affinity mask, the kernel is free to migrate the process or interrupt based on load and other considerations, but only to another CPU in the affinity mask. The default condition is affinity to execute on all CPUs in the system; however, specifications can be made through `mpadvise(3)`, `shield(1)`, `sched_setaffinity(2)` and the `/proc` file system. Using affinity with *shielded CPUs* can provide better determinism in application code.

AGP

A bus specification by Intel which gives low-cost 3D graphics cards faster access to main memory on personal computers than the usual PCI bus.

async-safe

When a library routine can be safely called from within signal handlers. A thread that is executing some async-safe code will not *deadlock* if it is interrupted by a signal. This is accomplished by blocking signals before obtaining locks.

atomic

All in a set of operations are performed at the same time and only if they can all be performed simultaneously.

authentication

Verification of the identity of a username, password, process, or computer system for security purposes. *PAM* provides an authentication method on RedHawk Linux.

blocking message operation

Suspending execution if an attempt to send or receive a message is unsuccessful.

blocking semaphore operation

Suspending execution while testing for a semaphore value.

breakpoint

A location in a program at which execution is to be stopped and control of the processor switched to the debugger.

busy-wait

A method of *mutual exclusion* that obtains a lock using a hardware-supported test and set operation. If a process attempts to obtain a busy-wait lock that is currently in a locked state, the locking process continues to retry the test and set operation until the process that currently holds the lock has cleared it and the test and set operation succeeds. Also known as a *spin lock*.

capabilities

A division of the *privileges* traditionally associated with superuser into distinct units that can be independently enabled and disabled. The current set of all valid Linux capabilities can be found in `/usr/include/linux/capability.h` and detailed in Appendix C. Through *PAM*, a non-root user can be configured to run applications that require privileges only root would normally be allowed.

condition synchronization

Utilizing sleep/wakeup/timer mechanisms to delay a process' progress until an application-defined condition is met. In RedHawk Linux, the `postwait(2)` and `server_block(2)/server_wake(2)` system calls are provided for this purpose.

context switch

When a multitasking operating system stops running one process and starts running another.

critical section

A sequence of instructions that must be executed in sequence and without interruption to guarantee correct operation of the software.

deadlock

Any of a number of situations where two or more processes cannot proceed because they are both waiting for the other to release some resource.

deferred interrupt handling

A method by which an interrupt routine defers processing that would otherwise have been done at interrupt level. RedHawk Linux supports *softirqs*, *tasklets* and *work queues*, which execute in the context of a kernel daemon. The priority and scheduling policy of these daemons can be configured so that a high-priority *real-time* task can *preempt* the activity of deferred interrupt functions.

determinism

A computer system's ability to execute a particular code path (a set of instructions executed in sequence) in a fixed amount of time. The extent to which the execution time for the code path varies from one instance to another indicates the degree of determinism in the system. Determinism applies to both the amount of time required to execute a time-critical portion of a user's application and to the amount of time required to execute system code in the kernel.

deterministic system

A system in which it is possible to control the factors that impact *determinism*. Techniques available under RedHawk Linux for maximizing determinism include *shielded CPUs*, *fixed priority scheduling policy*, *deferred interrupt handling*, *load balancing* and unit control of *hyper-threading*.

device driver

Software that communicates directly with a computer hardware component or peripheral, allowing it to be used by the operating system. Also referred to as device module or driver.

direct I/O

An unbuffered form of I/O that bypasses the kernel's buffering of data. With direct I/O, the file system transfers data directly between the disk and the user-supplied buffer.

discretionary access control

Mechanisms based on usernames, passwords or file access permissions that check the validity of the credentials given them at the discretion of the user. This differs from mandatory controls, which are based on items over which the user has no control, such as the IP address.

execution time

The amount of time it takes to complete a task. Using the high resolution process accounting facility in RedHawk Linux, execution time measurements for each process are broken down into system, user, interrupted system and interrupted user times measured with the high resolution time stamp counter (TSC).

FBS

See *Frequency-Based Scheduler (FBS)*.

fixed priority scheduling policy

A scheduling policy that allows users to set static priorities on a per-process basis. The scheduler never modifies the priority of a process that uses one of the fixed priority scheduling policies. The highest fixed-priority process always gets the CPU as soon as it is runnable, even if other processes are runnable. There are two fixed priority scheduling policies: SCHED_FIFO and SCHED_RR.

flavor

A variation of a single entity. RedHawk Linux has three flavors of pre-built kernels, each containing different characteristics and configurations. A customized kernel would constitute another flavor. The flavor designation is defined in the top level Makefile and appended as a suffix to the kernel name when the kernel is built; e.g, <kernelname>-**trace**.

Frequency-Based Scheduler (FBS)

A task synchronization mechanism used to initiate processes at specified frequencies based on a variety of timing sources, which include high-resolution clocks provided by the Real-Time Clock and Interrupt Module (*RCIM*), an external interrupt source, or the completion of a cycle. The processes are then scheduled using a priority-based scheduler. When used in conjunction with the *Performance Monitor (PM)*, FBS can be used to determine the best way of allocating processors to various tasks for a particular application.

The *NightSim* tool is a graphical interface to the Frequency-Based Scheduler and Performance Monitor.

GRUB

GRand Unified Bootloader. A small software utility that loads and manages multiple operating systems (and their variants). GRUB is the default bootloader for RedHawk Linux.

hyper-threading

A feature of the Intel Pentium Xeon processor that allows for a single physical processor to run multiple threads of software applications simultaneously. Each processor has two sets of architecture state while sharing one set of processor execution resources. Each architecture state can be thought of as a logical CPU resulting in twice as many logical CPUs in a system. A uniprocessor system with hyper-threading enabled has two logical CPUs, making it possible to *shield* one of them from interrupts and background processes. Hyper-threading is enabled by default in all RedHawk Linux i386 pre-built kernels.

info page

Info pages give detailed information about a command or file. Its companion, *man pages*, tend to be brief and provide less explanation than info pages. Info pages are interactive with a navigable menu system. An info page is accessed using the **info(1)** command.

interprocess communication (IPC)

A capability that allows one process to communicate with another process. The processes can be running on the same computer or on different computers connected through a network. IPC enables one application to control another application, and for several applications to share the same data without interfering with one another. IPC methods include pipes, *message queues*, *semaphores*, *shared memory* and sockets.

interprocess synchronization

Mechanisms that allow cooperating processes to coordinate access to the same set of resources. RedHawk Linux supplies a variety of interprocess synchronization tools including *rescheduling variables*, *busy-wait* and *sleepy-wait mutual exclusion* mechanisms and *condition synchronization* tools.

jitter

The size of the variation in the arrival or departure times of a periodic action. When the worst-case time measured for either executing a code segment or responding to an interrupt is significantly different than the typical case, the application's performance is said to be experiencing jitter. Jitter normally causes no problems as long as the actions all stay within the correct period, but *real-time* tasks generally require that jitter be minimized as much as possible.

journaling file system

A file system whereby disk transactions are written sequentially to an area of disk called a journal or log before being written to their final locations within the filesystem. If a crash occurs before the journal entry is committed, the original data is still on the disk and only new changes are lost. When the system reboots, the journal entries are replayed and the update that was interrupted is completed, greatly simplifying recovery time. Journaling file systems in RedHawk Linux include ext3, xfs and reiserfs.

kernel

The critical piece of an operating system which performs the basic functions on which more advanced functions depend. Linux is based on the kernel developed by Linus Torvalds and a group of core developers. Concurrent has modified the Linux kernel distributed by Red Hat to provide enhancements for *deterministic real-time* processing. RedHawk Linux supplies three pre-built kernels with the following *flavors*: generic, debug and trace. They reside as files named **vmlinuz-<kernelversion>-RedHawk-<revision.level>-<flavor>** in the **/boot** directory.

Kernel Configuration GUI

The graphical interface from which selections are made for configuring a kernel. In RedHawk Linux, running the **ccur-config** script displays the GUI where selections can be made.

load balancing

Moving processes from some CPUs to balance the load across all CPUs.

man page

A brief and concise online document that explains a command or file. A man page is displayed by typing **man** at the shell prompt followed by a space and then the term you want to read about. Man pages in RedHawk Linux include those provided with the Red Hat Linux distribution as well as those describing functionality developed by Concurrent.

memory object

Named regions of storage that can be mapped to the address space of one or more processes to allow them to share the associated memory. Memory objects include *POSIX shared memory* objects, regular files, and some devices, but not all file system objects (terminals and network devices, for example). Processes can access the data in a memory object directly by mapping portions of their address spaces onto the objects, which eliminates copying the data between the *kernel* and the application.

message queues

An *interprocess communication (IPC)* mechanism that allows one or more processes to write messages which will be read by one or more reading processes. RedHawk Linux includes support for *POSIX* and *System V* message queue facilities.

module

A collection of routines that perform a system-level function. A module may be loaded and unloaded from the running *kernel* as required.

mutex

A *mutual exclusion* device useful for protecting shared data structures from concurrent modifications and implementing *critical sections*. A mutex has two possible states: unlocked (not owned by any thread) and locked (owned by one thread). A thread attempting to lock a mutex that is already locked by another thread is suspended until the owning thread unlocks the mutex first.

mutual exclusion

A mechanism that ensures that only one of a set of cooperating processes can be executing in a *critical section* at a time by serializing access to shared resources. Three types of mechanisms are typically used to provide mutual exclusion—those that involve *busy-waiting*, those that involve *sleepy-waiting*, and a combination of the two.

NightProbe

A graphical user interface (GUI) developed by Concurrent that permits *real-time* recording, viewing, and modification of program data within one or more executing programs. It can be used during development and operation of applications, including simulations, data acquisition, and system control.

NightSim

A graphical user interface (GUI) to the *Frequency-Based Scheduler (FBS)* and *Performance Monitor (PM)* facilities.

NightStar RT Tools

A collection of development tools supplied by Concurrent that provide a graphical interface for scheduling, monitoring, debugging and analyzing run time behavior of *real-time* applications. The toolset includes the *NightSim* periodic scheduler, *NightProbe* data monitor, *NightTrace* event analyzer, *NightTune* tuner and *NightView* debugger.

NightTrace

A graphical tool developed by Concurrent used for analyzing the dynamic behavior of multiprocess and/or multiprocessor user applications and operating system activity. The NightTrace RT toolset consists of an interactive debugging and performance analysis tool, trace data collection daemons, and an Application Programming Interface (API).

NightTune

A graphical tool developed by Concurrent for analyzing system and application performance including CPU usage, context switches, interrupts, virtual memory usage, network activity, process attributes, and CPU shielding. NightTune allows you to change the priority, scheduling policy, and CPU affinity of individual or groups of processes using pop-up dialogs or drag-and-drop actions. It also allows you to set the shielding and hyper-threading attributes of CPUs and change the CPU assignment of individual interrupts.

NightView

A general-purpose, graphical source-level debugging and monitoring tool designed by Concurrent for *real-time* applications written in C, C++, and Fortran. NightView RT can monitor, debug, and patch multiple real-time processes running on multiple processors on the local system or on different targets with minimal intrusion.

nonblocking message operation

Not suspending execution if an attempt to send or receive a message is unsuccessful.

nonblocking semaphore operation

Not suspending execution while testing for a *semaphore* value.

NUMA

Non-Uniform Memory Architecture. A memory architecture used in some multiprocessors where access to different classes of memory takes significantly different amounts of time. A processor can access its own local memory faster than non-local memory (memory which is local to another processor or shared between processors).

PAM

Pluggable Authentication Module. A method that allows a system administrator to set access and *authentication* policies without having to separately recompile individual programs for such features. Under this scheme, a non-root user can be configured to run applications that require *privileges* only root would normally be allowed.

PCI

Peripheral Component Interface. A peripheral bus that provides a high-speed data path between the processor and peripheral devices like video cards, sound cards, network interface cards and modems. PCI provides “plug and play” capability, runs at 33MHz and 66 MHz and supports 32-bit and 64-bit data paths.

Performance Monitor (PM)

A facility that makes it possible to monitor use of the CPU by processes that are scheduled on a *frequency-based scheduler*. Values obtained assist in determining how to redistribute processes among processors for improved *load balancing* and processing efficiency. *NightSim* is a graphical interface to the Performance Monitor.

Pluggable Authentication Module (PAM)

See *PAM*.

POSIX

A standard specifying semantics and interfaces for a UNIX-like kernel interface, along with standards for user-space facilities. There is a core POSIX definition which must be supported by all POSIX-conforming operating systems, and several optional standards for specific facilities; e.g., POSIX message queues.

preemption

When a process that was running on a CPU is replaced by a process with a higher priority. Kernel preemption included in RedHawk Linux allows a lower priority process to be preempted, even if operating in kernel space, resulting in improved system response. Process preemption can be controlled through the use of *rescheduling variables*.

priority inheritance

A mechanism that momentarily passes along the priority of one process to another as needed to avoid *priority inversion*.

priority inversion

When a higher-priority process is forced to wait for the execution of a lower-priority process.

privilege

A mechanism through which users or processes are allowed to perform sensitive operations or override system restrictions. Superuser possesses all (root) privileges. Through *capabilities*, privileges can be enabled or disabled for individual users and processes.

process

An instance of a program that is being executed. Each process has a unique PID, which is that process' entry in the kernel's process table.

process dispatch latency

The time that elapses from the occurrence of an external event, which is signified by an interrupt, until the process waiting for that external event executes its first instruction in user mode.

RCIM

Real-Time Clock and Interrupt Module. A multifunction PCI card designed by Concurrent for fully deterministic event synchronization in multiple CPU applications. The RCIM includes a synchronized clock, multiple programmable real-time clocks, and multiple input and output external interrupt lines. Interrupts can be shared (distributed) across interconnected systems using an RCIM chain.

real-time

Responding to a real-world event and completing the processing required to handle that event within a given deadline. Computations required to respond to the real-world event must be complete before the deadline or the results are considered incorrect. RedHawk Linux is a true real-time operating system (RTOS) because it can guarantee a certain capability within a specified time constraint.

rescheduling variable

A data structure, allocated on a per-process basis by the application, that controls a single process' vulnerability to rescheduling.

robust mutex

A *mutex* that gives applications a chance to recover if one of the application's threads dies while holding the mutex.

RPM

RPM Package Manager. A management system of tools, databases and libraries used for installing, uninstalling, verifying, querying, and updating computer software packages. See the **rpm(8)** man page for complete information.

semaphore

A location in memory whose value can be tested and set by more than one process. A semaphore is a form of *sleepy-wait mutual exclusion* because a process that attempts to lock a semaphore that is already locked will be blocked or put to sleep. RedHawk Linux provides *POSIX* counting semaphores that provide a simple interface to achieve the fastest performance, and *System V* semaphores that provide many additional functions (for example the ability to find out how many waiters there are on a semaphore or the ability to operate on a set of semaphores).

shared memory

Memory accessible through more than one process' virtual address map. Using shared memory, processes can exchange data more quickly than by reading and writing using the regular operating system services. RedHawk Linux includes standardized shared memory interfaces derived from *System V* as well as *POSIX*.

shielded CPU

A CPU that is responsible for running high-priority tasks that are protected from the unpredictable processing associated with interrupts and system daemons. Each CPU in a RedHawk Linux system can be individually shielded from background processes, interrupts and/or the local timer interrupt.

shielded CPU model

A model whereby tasks and interrupts are assigned to CPUs in a way that guarantees a high grade of service to certain important real-time functions. In particular, a high-priority task is bound to one or more shielded CPUs, while most interrupts and low priority tasks are bound to other CPUs. The CPUs responsible for running the high-priority tasks are

shielded from the unpredictable processing associated with interrupts and the other activity of lower priority processes that enter the kernel via system calls.

shielded processor

See *shielded CPU*.

sleepy-wait

A method of *mutual exclusion* such as a *semaphore* that puts a process to sleep if it attempts to obtain a lock that is currently in a locked state

SMP

Symmetric multi-processing. A method of computing which uses two or more processors managed by one operating system, often sharing the same memory and having equal access to input/output devices. Application programs may run on any or all processors in a system.

softirq

A method by which the execution of a function can be delayed until the next available “safe point.” Instead of invoking the function, a “trigger” that causes it to be invoked at the next safe point is used instead. A safe point is any time the kernel is not servicing a hardware or software interrupt and is not running with interrupts blocked.

spin lock

A *busy-wait* method of ensuring *mutual exclusion* for a resource. Tasks waiting on a spin lock sit in a busy loop until the spin lock becomes available.

System V

A standard for *interprocess communication (IPC)* objects supported by many UNIX-like systems, including Linux and System V systems. System V IPC objects are of three kinds: System V *message queues*, *semaphore* sets, and *shared memory* segments.

tasklet

A software interrupt routine running when the software interrupt is received at a return to user space or after a hardware interrupt. Tasklets do not run concurrently on multiple CPUs, but are dynamically allocatable.

TLB

Translation Look-aside Buffer. A table used in a virtual memory system, that lists the physical address page number associated with each virtual address page number. A TLB is used in conjunction with a cache whose tags are based on virtual addresses. The virtual address is presented simultaneously to the TLB and to the cache so that cache access and the virtual-to-physical address translation can proceed in parallel

trace event

Logged information for a point of interest (trace point) in an application's source code or in the kernel that can be examined by the *NightTrace* tool for debugging and performance analysis.

work queues

A method of deferred execution in addition to *softirqs* and *tasklets*, but unlike those forms, Linux processes work queues in the process context of kernel daemons and therefore are capable of sleeping.

Paths

- /boot directory 11-1
- /dev/mqueue 3-2
- /etc/pam.d 13-2
- /etc/rc.sysinit 2-17
- /etc/security/capability.conf 13-2, 13-3
- /etc/sysconfig/kdump 12-3
- /etc/sysconfig/sbsvme 15-6
- /etc/sysconfig/sbsvme-mappings 15-7
- /proc file system 1-6
- /proc/bus/pci 3-28, 14-1
- /proc/ccur B-3
- /proc/driver/btp 15-7, 15-15, 15-16
- /proc/driver/graphics-memory G-4
- /proc/interrupts 2-18
- /proc/irq/n/smp_affinity 2-10, 2-19
- /proc/mtrr G-2
- /proc/pid/affinity B-3
- /proc/pid/mem 9-1–9-4
- /proc/pid/resmem B-3
- /proc/shield/irqs 2-14, 2-18
- /proc/shield/ltmrs 2-14, 7-4
- /proc/shield/procs 2-14
- /proc/sysvipc/shm 3-15, 3-28
- /proc/vmcore 12-2
- /usr/lib/libccur_rt 9-3, 14-3
- /usr/lib64/libnuma.so 10-11

Numerics

- 32-bit 1-1, 11-2
- 64-bit
 - code migration E-1
 - kernels 1-1, 11-2, E-1

A

- affinity 2-10, 2-14–2-19, 4-6, 4-13
- alternative glibc 5-27
- AMD Opteron processor E-1
- asynchronous I/O 1-10
- AUDIT B-3

- authentication 13-1

B

- bar_device_count 14-4
- bar_mmap 14-5
- bar_munmap 14-5
- bar_scan_close 14-4
- bar_scan_next 14-3
- bar_scan_open 14-3
- bar_scan_rewind 14-4
- base address registers (BARs) 3-26, 14-1, B-3
- bash command 7-4
- Big Kernel Lock (BKL) 14-14, B-5
- bind shared memory to I/O space 3-22, 3-23, 3-25
- block a process 5-37–5-41
- boot command line parameters I-1
- bottom halves 14-12
- btp module 15-6
- building a kernel 11-4
- busy-wait mutual exclusion 5-2, 5-7–5-12

C

- cache thrashing 2-22
- capabilities 13-3, B-2, C-1
- ccur-config 11-2
- ccur-g++ 5-27
- ccur-gcc 5-27
- CD/DVD burning 2-34
- clock_getres 6-5
- clock_gettime 6-5
- clock_nanosleep 6-11, 6-12
- clock_settime 6-4
- clocks
 - POSIX 1-11, 6-1, 6-2, 6-4–6-5
 - RCIM 1-5, 6-1, 7-1
 - system time-of-day (wall) 6-4, 7-1
 - TSC 7-1
- clocksource 7-1
- condition synchronization 5-1, 5-37
- configuring a kernel 11-2, B-1
- console, serial setup H-1

counting semaphores 1-10, 5-2, 5-12–5-21

CPU

accounting 1-7, 2-11, 7-2, B-2

affinity 2-10, 2-14–2-19, 4-6, 4-13

identification 2-29

idling 2-29–2-31, B-2

load balancing 7-3

logical/physical 2-29

rescheduling 7-4

shielding, *see* shielded CPUs

cpu command 2-18, 2-29–2-31

CPU_IDLING B-2

crash dump 12-1, B-5

crash utility 12-5

CRASH_DUMP 12-3, B-5

crashkernel I-2

cross processor interrupts B-4, G-1

D

daemon control 14-13, 14-14, F-1

DAEMON_CPU_LOCK B-2

Data Management API (DMAPI) 8-2

data sharing 1-10

debug kernel 1-3, 11-2

DEBUG_INFO 12-3, B-5

debugger 1-6, 1-8, 12-8, B-5

deferred interrupt functions 14-12

DETECT_SOFTLOCKUP 2-35, B-4

determinism 2-2, 2-20, 2-34

device drivers 2-9, 11-5, 14-1

direct I/O 8-1

disk I/O 8-1

DMAPI 8-2

documentation v

dump 12-1, B-5

DVD/CD burning 2-34

E

EM64T processor E-1

examples

add module to kernel 11-6

authentication 13-3, 13-4

busy-wait mutual exclusion 5-9

condition synchronization 5-42

CPU affinity for init 2-17

CPU shielding 2-13, 2-17, 2-31–2-34

crash dumps 12-6, 12-7

device driver 14-6, 14-9

kernel configuration and build 11-5

messaging 3-7, 3-9, 3-10, A-1

NUMA 10-14

PCI BAR scan 14-3

PCI-to-VME 15-17

POSIX message queues A-1

rescheduling control 5-7

reserving physical memory 2-23, 2-25

run command 4-14

semaphores 5-34, 5-36

set process priorities 4-4

shared memory 3-19, 3-21, 3-23

shielded CPU 2-13, 2-17, 2-31–2-34

System V message queues A-4

F

FBSCHED B-3

FBSCHED_PM B-3

FIFO scheduling 4-1, 4-3

file systems 8-1

floating point operations 2-33

free_pci_device 14-5

Frequency-Based Scheduler (FBS) 1-1, 1-5, B-3

fstat 3-12

ftok 3-27

ftruncate 3-12–3-14

G

get_mempolicy 10-11

glibc 5-27

glossary Glossary-1

graphics

interrupts G-3

support 10-5, B-5

H

haldaemon 2-34

high resolution process accounting 1-7, 2-11, 7-2, B-2

HRACCT 7-2, B-2

hyper-threading 1-8, 2-28–2-34, B-5

HyperTransport 2-27

I

I/O

asynchronous 1-10

direct 8-3

disk 8-1

synchronized 1-10

- throughput on quad Opterons 2-27
- userspace (UIO) 14-15, B-5
- iHawk systems 1-1, 11-2
- INHERIT_CAPS_ACROSS_EXEC 13-5, B-2
- init 2-15–2-17
- interprocess communications, *see* System V IPC
- interprocess synchronization 5-1
- interrupts
 - /proc interface 2-18, 2-19
 - cross processor B-4, G-1
 - deferred functions 2-21, 14-12
 - disabling 2-10–2-14, 7-2, 7-4
 - effect of disabling 2-4
 - effect of receiving 2-5–2-7
 - graphics G-3
 - local timer, *see* local timer
 - MTRR G-1
 - NMI 12-8, I-3
 - NVIDIA CUDA G-4
 - RCIM 1-5
 - response time improvements 1-7
 - routines in device drivers 14-11
 - shield CPU from 2-10–2-14, 2-31
 - softirqs 4-5, 14-12, B-3
 - tasklets 4-5, 14-12
 - TLB flush G-5
 - work queues 14-12, 14-13
- interval timer 7-3
- ioremap 14-11
- IP route cache table 2-35, I-4
- IPC, *see* System V IPC
- IRQ 2-10, 2-12, 2-14, 2-19, I-3

J

- journaling file system 1-9, 8-1

K

- K8_NUMA B-4
- KDB B-5
- kdb 1-8, 10-13, 12-8, I-2
- KDB_CONTINUE_CATASTROPHIC B-5
- KDB_MODULES B-5
- KDB_OFF B-5
- kdump 12-1, 12-2
- kernel
 - add module example 11-6
 - boot 1-3
 - build 11-1
 - configuration 11-1, B-1
 - crash dump 12-2, B-5

- daemon control 14-13, 14-14, F-1
- debug 1-3, 11-2
- debugger 1-6, 1-8, 12-8, B-5
- debugging 12-1
- flavors 1-3, 11-1, 11-2
- generic/optimized 1-3, 11-2
- preemption 1-6, B-4
- reserve space 14-11, B-4
- trace 1-3, 11-2
- trace events 14-16, D-1
- tracing 1-6, B-5
- tunable parameters 11-1, 11-3, B-1
- updates 1-4
- virtual address space reserves 14-11, B-4
- KEXEC 12-3, B-5
- kexec 12-2
- ksoftirqd 2-35, 14-13, B-3, I-4

L

- LARGE_MMAP_SPACE B-3
- libraries 3-3, 5-2, 5-14, 5-27, 10-11
- Linux Documentation Project web site 11-7
- load balancing 7-3
- local timer
 - disabling 2-11–2-14, 7-4
 - functionality 7-1
- LOCK_BREAK_THROTTLE B-4
- LOCK_BREAK_THROTTLE_LIMIT B-4
- low latency patches 1-7
- low memory 2-34

M

- mailbox 5-42
- mbind 10-11
- memmap 2-23, I-2
- memory access, non-uniform (NUMA) 2-27, 10-1
- memory locking 4-6, 5-2
- memory mapping 1-10, 9-1, B-3
- memory policies (NUMA) 10-2
- memory resident processes 1-9
- memory shielding (NUMA) 10-3
- memory, low 2-34
- memory, reserving physical 2-22
- MEMSHIELD_ZONE_NORMAL 10-16
- MEMSHIELD_ZONELIST_ORDER 10-16, B-4
- message queue structures
 - POSIX 3-2
 - System V 3-4, 3-5
- messaging 3-1, A-1, B-2
- mlock 1-9, 2-20, 4-6

- mlockall 1-9, 2-20, 4-6
- mmap 1-8, 9-1, 9-4, 14-5, B-3
- mpadvise 2-15
- mq_close 3-2
- mq_getattr 3-2
- mq_notify 3-2
- mq_open 3-2
- mq_receive 3-2
- mq_send 3-2
- mq_setattr 3-2
- mq_unlink 3-2
- mqueue 3-2
- msgctl 3-3, 3-6, 3-9
- msgget 3-3, 3-5, 3-7
- msgop 3-6
- msgrcv 3-10
- msgsnd 3-10
- munlock 1-9, 2-20, 4-6
- munlockall 1-9, 2-20, 4-6
- mutex 5-2, 5-27
 - attribute objects 5-23
 - compiling 5-27
 - nopreempt spin 5-10
 - priority inheritance 5-23
 - pthread 5-21, 5-23
 - robust 5-22
 - spin 5-7
 - state 5-23
- mutual exclusion 5-1, 5-14

N

- nanosleep 2-11, 6-11, 7-4
- NightProbe 1-2, 1-6
- NightSim 1-2, 1-5
- NightStar RT tools 1-1, 1-2, 11-2
- NightTrace 1-2, 1-3, 1-6, 11-2, 14-16, D-1
- NightTune 1-2
- NightView 1-2, 1-6
- NMI interrupts 12-8, I-3
- nmi_dump 12-8, I-2
- nmi_watchdog 12-8, I-3
- NO_HZ B-2, I-3
- NO_HZ_ENABLED B-2, I-3
- no_pregraph_pgs 10-7, I-3
- noatime 2-35
- noirqbalance I-3
- non-uniform memory access (NUMA) 2-27, 10-1
- nopreempt_spin_init 5-11
- nopreempt_spin_init_thread 5-11
- nopreempt_spin_islock 5-11
- nopreempt_spin_lock 5-11
- nopreempt_spin_mutex 5-10

- nopreempt_spin_trylock 5-11
- nopreempt_spin_unlock 5-11
- NTP_PPS B-2
- NUMA 2-27, 10-1, B-4
- NUMA 10-15, B-4
- numa I-3
- numapgs utility 10-12
- NVIDIA B-5
- NVIDIA graphics support B-5, G-3

O

- one-shot timer 6-2
- Opteron
 - processor E-1
 - quad I/O throughput 2-27
- optimized kernel 1-3, 11-2

P

- PAGE_REPLICATION 10-16, B-4
- PAGE_REPLICATION_DYNAMIC 10-16, B-4
- paging 1-9
- PAM 1-7, 13-1, B-2
- pam_capability 13-2
- PCI resource access 14-1, B-3
- PCI-to-VME support
 - bind buffers 15-9
 - configuration 15-6, B-3
 - documentation 15-2
 - examples 15-17
 - installation 15-2, 15-5
 - overview 15-1
 - user interface 15-7
 - VMEbus mappings 15-7, 15-13
- performance issues
 - cache thrashing 2-22
 - cross processor interrupts G-1
 - deferred interrupts 2-21, 14-12
 - device drivers 14-11
 - direct I/O 8-4
 - disabling local timer 7-2
 - hyper-threading 2-30
 - I/O throughput on quad Opterons 2-27
 - kernel daemons F-1
 - kernel tracing 14-16
 - locking pages in memory 2-20, 4-6
 - negative impacts 2-34
 - NUMA programming 2-27, 10-14
 - optimized kernel 1-3, 11-2
 - priority scheduling 2-20, 4-4, 4-5
 - reserving physical memory 2-22

- shielding CPUs 2-9–2-11, 4-6, F-1, G-1
- softirqs 4-5, 14-13, F-1
- tasklets 4-5, 14-13, F-1
- waking a process 2-21, 5-37–5-41
- work queues F-1
- Performance Monitor 1-1, 1-7, B-3
- periodic timer 6-2
- physical memory reservation 2-22
- Pluggable Authentication Modules (PAM) 1-7, 13-1, B-2
- POSIX conformance 1-2
- POSIX facilities
 - asynchronous I/O 1-10
 - clock routines 6-4–6-5
 - clocks 1-11, 6-1, 6-2
 - counting semaphores 1-10, 5-2, 5-12–5-21
 - memory locking 1-9, 2-20, 4-6
 - memory mapping 1-10
 - message queues 3-2, A-1, B-2
 - pthread mutexes 5-21
 - real-time extensions 1-9
 - real-time signals 1-11
 - scheduling policies 4-1, 4-3
 - semaphores 1-10, 5-2, 5-12–5-21
 - shared memory 1-10, 3-12–3-15
 - sleep routines 6-11, 6-12
 - timers 1-11, 2-11, 6-2, 6-6–6-10, 7-4
- POSIX routines
 - clock_getres 6-5
 - clock_gettime 6-5
 - clock_settime 6-4
 - mlock 1-9, 2-20, 4-6
 - mlockall 1-9, 2-20, 4-6
 - mq_close 3-2
 - mq_getattr 3-2
 - mq_notify 3-2
 - mq_open 3-2
 - mq_receive 3-2
 - mq_send 3-2
 - mq_setattr 3-2
 - mq_unlink 3-2
 - munlock 1-9, 2-20, 4-6
 - munlockall 1-9, 2-20, 4-6
 - pthread_mutex_consistent_np 5-24
 - pthread_mutex_destroy 5-21
 - pthread_mutex_getunlock_np 5-24
 - pthread_mutex_init 5-21
 - pthread_mutex_lock 5-21
 - pthread_mutex_setconsistency_np 5-24
 - pthread_mutex_setunlock_np 5-25
 - pthread_mutex_trylock 5-21
 - pthread_mutex_unlock 5-21
 - pthread_mutexattr_destroy 5-21
 - pthread_mutexattr_getfast_np 5-25
 - pthread_mutexattr_gettype 5-21
 - pthread_mutexattr_init 5-21
 - pthread_mutexattr_setfast_np 5-26
 - pthread_mutexattr_setprotocol 5-27
 - pthread_mutexattr_setrobust_np 5-27
 - pthread_mutexattr_settype 5-21
 - pthread_mutexattr_setunlock_np 5-27
 - sched_get_priority_max 4-11, 4-12
 - sched_get_priority_min 4-11
 - sched_getparam 4-10
 - sched_getscheduler 4-8
 - sched_rr_get_interval 4-12
 - sched_setparam 4-9
 - sched_setscheduler 4-7
 - sched_yield 4-10
 - sem_destroy 5-15
 - sem_getvalue 5-21
 - sem_init 5-12, 5-14
 - sem_open 5-16
 - sem_post 5-20
 - sem_timedwait 5-19
 - sem_trywait 5-20
 - sem_unlink 5-18
 - sem_wait 5-19
 - shm_open 3-12, 3-13
 - shm_unlink 3-12, 3-15
 - sigqueue 1-11
 - sigtimedwait 1-11
 - sigwaitinfo 1-11
 - timer_create 6-6
 - timer_delete 6-8
 - timer_getoverrun 6-10
 - timer_gettime 6-9
 - timer_settime 6-8
- POSIX_MQUEUE B-2
- post/wait 5-37, B-2
- POST_WAIT B-2
- PPSAPI B-2
- PPSAPI_SERIAL B-2
- PREALLOC_GRAPHICS_PAGES B-4
- preallocated graphics pages 10-5
- PREEMPT B-4
- preemption 1-5, 1-6, 2-8, 5-3, B-4
- prefer_highmem I-4
- priorities
 - kernel daemon 14-13, 14-14
 - process 4-1, 4-2
- priority inheritance 1-7, 5-23
- priority inversion 1-7
- PROC_CCUR_DIR B-3
- PROC_PCI_BARMAP B-3
- PROC_PID_AFFINITY B-3
- PROC_PID_RESMEM B-3
- process

- assign to CPU(s) 2-14–2-17
- block 5-37–5-41
- cooperating 5-37
- dispatch latency 2-2, 2-3
- execution time quantum 4-4–4-5, 4-8, 4-12, 4-13, 7-3
- memory resident 1-9
- priorities 4-1, 4-2
- scheduling 4-1, 7-3
- synchronization 1-10, 5-1
- wake 2-21, 5-37–5-41
- Process Scheduler 4-2
- PROCMEM_ANYONE 9-4, B-3
- PROCMEM_MMAP 9-4, B-3
- PROCMEM_WRITE B-3
- profiling 7-3
- programmed I/O on quad Opterons 2-28
- ps command 4-3, 7-2
- pthread_mutex_consistent_np 5-24
- pthread_mutex_destroy 5-21
- pthread_mutex_getunlock_np 5-24
- pthread_mutex_init 5-21
- pthread_mutex_lock 5-21
- pthread_mutex_setconsistency_np 5-24
- pthread_mutex_setunlock_np 5-25
- pthread_mutex_trylock 5-21
- pthread_mutex_unlock 5-21
- pthread_mutexattr_destroy 5-21
- pthread_mutexattr_getfast_np 5-25
- pthread_mutexattr_gettype 5-21
- pthread_mutexattr_init 5-21
- pthread_mutexattr_setfast_np 5-26
- pthread_mutexattr_setprotocol 5-27
- pthread_mutexattr_setrobust_np 5-27
- pthread_mutexattr_settype 5-21
- pthread_mutexattr_setunlock_np 5-27
- ptrace 1-6, B-4
- PTRACE_EXT B-4
- publications, related v

R

- rcim I-4
- RCIM_CLOCKSOURCE B-2
- RCIM_IRQ_EXTENSIONS B-3
- RCIM_PPS B-2
- RCU 7-4, B-2
- RCU_ALTERNATIVE 7-4, B-2
- read copy update (RCU) 7-4, B-2
- Real-Time Clock and Interrupt Module (RCIM) 1-5, 6-1, B-2, B-3, I-4
- real-time clock timers 6-2
- real-time features 1-4

- real-time process scheduling 4-1
- real-time scheduler 1-7
- real-time signals 1-11
- Red Hat distribution 1-1
- RedHawk Linux
 - capabilities C-1
 - documentation set v
 - kernel parameters 11-1, 11-3, B-1
 - kernels 1-3, 11-1, 11-2
 - POSIX conformance 1-2
 - real-time features 1-4
 - scheduler 4-2
 - updates 1-4
- related publications v
- REQUIRE_RELIABLE_TSC B-2
- REQUIRE_TSC B-2
- resched_cntl 5-4
- resched_lock 5-5
- resched_nlocks 5-6
- resched_unlock 5-6
- RESCHED_VAR B-2
- rescheduling control 5-3–5-7, 7-4
- rescheduling variables 5-3, B-2
- reserving physical memory 2-22
- rhash_entries 2-35, I-4
- robust mutex 5-22
- Role-Based Access Control 1-7, 13-2
- round-robin scheduling 4-1, 4-4
- RTC timers 6-2
- run command 2-15–2-17, 4-2, 4-13, 10-7

S

- SBS Technologies 15-1
- SBSVME 15-6, B-3
- SCHED_FIFO 4-1, 4-3
- sched_get_priority_max 4-11, 4-12
- sched_get_priority_min 4-11
- sched_getparam 4-10
- sched_getscheduler 4-8
- SCHED_OTHER 4-1, 4-4
- SCHED_RR 4-1, 4-4
- sched_rr_get_interval 4-12
- sched_setaffinity 2-15
- sched_setparam 2-21, 4-9
- sched_setscheduler 2-21, 4-7
- SCHED_SMT B-3
- SCHED_SMT_IDLE 2-35, B-3
- sched_yield 4-10
- scheduler, real-time 1-7
- scheduling policies 4-1, 4-3
- scheduling priorities 4-2
- sem_destroy 5-15

- sem_getvalue 5-21
 - sem_init 5-12, 5-14
 - sem_open 5-16
 - sem_post 5-20
 - sem_timedwait 5-19
 - sem_trywait 5-20
 - sem_unlink 5-18
 - sem_wait 5-19
 - semaphores
 - data structures 5-29
 - POSIX counting 5-2, 5-12–5-21
 - System V 5-2, 5-28–5-37
 - semctl 5-28, 5-34
 - semget 5-28, 5-30, 5-31
 - semop 5-28, 5-29, 5-36
 - serial console configuration H-1
 - server_block 5-39
 - server_wake1 5-40
 - server_wakevec 5-41
 - set_mempolicy 10-11
 - sh command 7-4
 - shared memory 1-10
 - NUMA 10-9
 - overview 3-1
 - POSIX 3-12–3-15
 - System V 3-15–3-28
 - shared resources 5-1
 - SHIELD B-2
 - shield command 2-12–2-14, 2-17, 7-4
 - shielded CPUs
 - cross processor interrupts G-1
 - examples 2-13, 2-17, 2-31–2-34, 10-14
 - interfaces 2-12
 - kernel daemons F-1
 - kernel parameters B-2
 - NUMA interface 10-3
 - overview 1-4, 2-1
 - performance 2-9–2-11, 4-6
 - uniprocessor 2-34
 - shm_open 3-12, 3-13
 - shm_unlink 3-12, 3-15
 - shmat 3-16, 3-23, 15-20
 - SHMBIND B-4
 - shmbind 3-22, 15-13, 15-20
 - shmconfig 3-16, 3-25, 10-9, 15-13, 15-21
 - shmctl 3-16, 3-21
 - shmdefine 3-16, 3-25
 - shmdt 3-16, 3-23
 - shmget 3-15, 3-19, 3-22, 3-27
 - sigqueue 1-11
 - sigtimedwait 1-11
 - sigwaitinfo 1-11
 - sleep routines 5-37, 6-11, 6-12
 - sleep/wakeup/timer mechanism 5-37
 - sleepy-wait mutual exclusion 5-2
 - SOFTIRQ_PREEMPT_BLOCK B-3
 - SOFTIRQ_PRI 14-13, B-3
 - softirqs 4-5, 14-12, 14-13, B-3, F-2
 - spin lock
 - BKL 14-14
 - busy-wait mutual exclusion 1-8, 5-1, 5-2, 5-7–5-12
 - condition synchronization 5-42
 - multithread device driver 14-14
 - nopreempt 5-10
 - preemption 1-5, 1-7
 - spin_init 5-8
 - spin_islock 5-9
 - spin_lock 5-8
 - spin_mutex 5-7
 - spin_trylock 5-9
 - spin_unlock 5-9
 - ssh 13-5
 - strace command 7-4
 - swapping 1-9
 - synchronized I/O 1-10
 - syntax notation iv
 - system profiling 7-3
 - system security 13-1
 - system updates 1-4
 - System V IPC
 - message queues 3-1, 3-3–3-11, A-4
 - semaphores 5-2, 5-28–5-37
 - shared memory 3-1, 3-15–3-28
 - System.map file 11-4
- ## T
- tasklets 4-5, 14-13
 - threads library 5-14
 - tickless kernel B-2, I-3
 - Time Stamp Counter (TSC) 7-1
 - time structures 6-3
 - time-of-day clock 6-4, 7-1
 - timer_create 6-6
 - timer_delete 6-8
 - timer_getoverrun 6-10
 - timer_gettime 6-9
 - timer_settime 6-8
 - timers
 - local 2-14, 7-1, 7-4
 - POSIX 1-11, 2-11, 6-2, 6-6–6-10, 7-4
 - RCIM RTC 6-2
 - system 7-1
 - time-share scheduling 4-1, 4-4
 - top command 4-3, 7-2
 - TRACE B-5
 - trace events, kernel 14-16, D-1

trace kernel 1-3, 11-2
trace points 1-6, 14-16
TSC 7-1

U

UIO 14-15, B-5
uniprocessor 2-34
UNSIGNED_OFFSETS B-4
updates, system 1-4
user authentication 13-1
user-level spin locks 1-8
usermap 1-8, 9-3, 9-4, B-3

V

virtual address space reserves 14-11, B-4
vmalloc 14-11, B-4, I-4
VMALLOC_PGTABLE_PRELOAD B-4
VMALLOC_RESERVE 14-11, B-4
vmalloc_sm I-4
vmcore 12-2, 12-5
VME-to-PCI support, *see* PCI-to-VME support
vmlinux 12-2, 12-5

W

wake a process 2-21, 5-37–5-41
wall clock 6-4, 7-1
work queues 14-12, 14-13

X

X86_64_ACPI_NUMA B-4
X86_HT 2-30, B-5
xfs 1-9, 8-1, B-4
XFS_DMAPI 8-2
XFS_FS B-4
XFS_RT B-4

