

Release Notes

CCURDSCC (WC-AD3224-DS)



<i>Driver</i>	ccurdsc (WC-AD3224-DS)	
<i>OS</i>	RedHawk	
<i>Vendor</i>	Concurrent Real-Time, Inc.	
<i>Hardware</i>	PCIe 32-Channel Delta Sigma Converter Card (CP-AD3224-DS) (CP-AD3224-DS-10)	
<i>Date</i>	August 23, 2018	rev 2018.1

This page intentionally left blank

Table of Contents

1. INTRODUCTION	1
2. REQUIREMENTS.....	1
3. DOCUMENTATION.....	2
4. INSTALLATION AND REMOVAL	2
4.1. Hardware Installation	2
4.2. Software Installation.....	3
4.3. Software Removal.....	4
5. AUTO-LOADING THE DRIVER	5
6. TESTING AND USAGE.....	5
7. RE-BUILDING THE DRIVER, LIBRARY AND TESTS	6
8. SOFTWARE SUPPORT	6
8.1. Device Configuration.....	6
8.2. Library Interface	7
8.3. Calibration.....	7
8.4. Firmware Updates.....	7
8.5. Debugging	7
9. NOTES AND ERRATA.....	9
APPENDIX A: EXTERNAL CONNECTIONS AND PIN-OUTS.....	10
APPENDIX B: THE 9277 (CP-AD3224-DS) +/- 5 VOLT BOARD	11
APPENDIX C: THE 9278 (CP-AD3224-DS-10) +/- 10 VOLT BOARD	11

This page intentionally left blank

1. Introduction

This document assists the user in installing the CCRT-PCIe-DSCC Linux **ccurdscc** driver and related software on the RedHawk OS for use with the CCRT-PCIe-DSCC board. The directions in this document supersede all others – they are specific to installing the software on Concurrent Real-Time's RedHawk systems. Other information provided as part of this release, when it may contradict these directions, should be ignored and these directions should prevail.

For additional information on this driver and usage refer to the **ccurdscc** man page.

The CCRT-PCIe-DSCC is a 32-channel analog to digital 24-bit delta sigma converter card with a PCI express interface. It is implemented using four Cirrus Logic CS5368 8-channel converters. The PCI interface utilizes a PLX Technology PEX-8311AA PCI-express-to-local bus bridge. There is a Lattice ECP2M FPGA for control of board functions including registers and storage. Each converter has an independently selectable clock source generated by a low jitter PLL. The external clocking interface consists of LVDS signaling connected via RJ-25 (6-pin) style cabling.

Features and Characteristics of the DSCC are:

9277 board (CP-AD3224-DS)

- Fully Differential +/-5V
- Differential Input Impedance >200K ohm
- Input Over-Voltage Protection +/-20V

9278 board (CP-AD3224-DS-10)

- Fully Differential +/-10V
- Differential Input Impedance >1Meg ohm
- Input Over-Voltage Protection +/-30V

Common to both boards

- 32-channel 24-bit Delta Sigma A to D Conversion.
- Industry Standard SCSI 68-pin Connector for Inputs.
- RJ-12 (6-pin phone style) Connectors for Multi-board Synchronization.
- PCI Express x1 Revision 1.0a.
- Supports MSI Interrupts.
- Independent Clocking for Four Channel Groups.
- Low Jitter Phase Lock Loop (PLL) Clock Generators.
- Supports Multi-board Clocking & Synchronization.
- Directly Addressable Conversion Data Registers.
- 64K Word Conversion Data FIFO with DMA.
- Low Noise Analog Power Generation.
- Positive and Negative Calibration Voltage.
- Gain and Offset Calibration Values Accessible.
- Sampling Rate (Fs) 2Khz to 216Khz.
- NIST Traceable Calibration Standard.
- Non-volatile Storage of Calibration Data & User Configuration.

The board and driver provide support for MSI interrupts. This is the default configuration.

2. Requirements

- CCRT-DSCC PCIe board physically installed in the system.
- Selected versions of RedHawk Revision 5.4, 6.0, 6.3, 6.5, 7.0, 7.2, 7.3, and 7.5. Actual supported versions depend on the driver being installed.

3. Documentation

- PCIe 32-Channel Delta Sigma Converter Card (DSCC) Software Interface by Concurrent Real-Time.
- PCIe 32-Channel Delta Sigma Converter Card (DSCC) Design Specification (No. 0610099) by Concurrent Real-Time.

4. Installation and Removal

4.1. Hardware Installation

The CCRT-DSCC card is a x1 PCI Express product and is compatible with any PCI Express slot. The board must be installed in the system before attempting to use the driver.



Caution: when installing the card insure the computer is powered off and the machine's power cord is disconnected. Please observe electrostatic discharge precautions such as the use of a grounding strap.

The *ccurdsc* driver is designed to support IRQ sharing. If this device's IRQ is being shared by another device then this driver's performance could be compromised. Hence, as far as possible, move this board into a PCI slot who's IRQ is not being shared with other devices.

An '*lspci -v*' or the '*lsirq*' command can be used to determine the IRQs of various devices in the system.

```
# lspci -v
```

```
# for 9277 (CP-AD3224-DS) +/- 5 Volt board
```

```
05:04.0 System peripheral: Concurrent Computer Corporation Device 9277 (rev 01)
```

```
Subsystem: PLX Technology, Inc. Device 9056
Flags: bus master, 66MHz, medium devsel, latency 96, IRQ 98
Memory at c4b01000 (32-bit, non-prefetchable) [size=512]
Memory at c4b00000 (32-bit, non-prefetchable) [size=2K]
Capabilities: <access denied>
```

```
# for 9278 (CP-AD3224-DS-10) +/-10 Volt board
```

```
06:04.0 System peripheral: Concurrent Computer Corporation 10 Volt Delta-Sigma Input Card (rev 01)
```

```
Subsystem: PLX Technology, Inc. Device 9056
Flags: bus master, 66MHz, medium devsel, latency 96, IRQ 51
Memory at fbbff400 (32-bit, non-prefetchable) [size=512]
Memory at fbbff800 (32-bit, non-prefetchable) [size=2K]
Capabilities: [40] Power Management version 2
Capabilities: [48] #00 [0000]
Capabilities: [4c] Vital Product Data
```

```
# lsirq
```

```
98      05:04.0 Concurrent Computer Corporation Unknown device (rev 01)
```

The default driver configuration uses MSI interrupts. If the kernel supports MSI interrupts, then sharing of interrupts will not occur, in which case the board placement will not be an issue.

After installing the card, reboot the system and verify the hardware has been recognized by the operating system by executing the following command:

```
# lspci -d 1542:9277
```

```
# lspci -d 1542:9278
```

For each CCRT-DSCC PCIe board installed, a line like one of the following will be printed, depending on the revision of the system's `/usr/share/hwdata/pci.ids` file:

```
05:04.0 System peripheral: Concurrent Computer Corporation Device 9277 (rev 01)
02:04.0 System peripheral: Concurrent Computer Corporation Device 9278 (rev 01)
```

If a line like the above is not displayed by the `lspci` command, the board has not been properly installed in the system. Make sure that the device has been correctly installed prior to attempting to use the software. One similar line should be found for each installed card.

4.2. Software Installation

Concurrent Real-Time™ port of the `ccurdscc` software is distributed in RPM and DEB format on a CD-ROM. Source for the API library, example test programs, and kernel loadable driver are included, as is documentation in PDF format.

The software is installed in the `/usr/local/CCRT/drivers/ccurdscc` directory. This directory will be referred to as the “top-level” directory by this document.



Warning: Before installing the software, the kernel build environment **must** be set up and match the current OS kernel you are using. If you are running one of the preconfigured kernels supplied by Concurrent Real-Time and have not previously done so, run the following commands while logged in as the root user before installing the driver software:

```
# cd /lib/modules/`uname -r`/build
# ./ccur-config -c -n
```

If you have built and are running a customized kernel configuration the kernel build environment should already have been set up when that custom kernel was built.

To install the `ccurdscc` package, load the CD-ROM installation media and issue the following commands as the **root** user. The system should auto-mount the CD-ROM to a mount point in the `/media` or `/run/media` directory based on the CD-ROM's volume label – in this case `ccurdscc_driver`. The example's `[user_name]` may be `root`, or the logged-in user. Then enter the following commands from a shell window:

```
== as root ==
--- on RedHawk 6.5 and below ---
# cd /media/ccurdscc_driver
--- or on RedHawk 7.0 and above ---
# cd /run/media/[user_name]/ccurdscc_driver
--- or on Ubuntu RedHawk ---
# cd /media/[user_name]/ccurdscc_driver

# rpm -ivh ccurdscc_RedHawk_driver*.rpm (on an RPM based system)
--- or ---
# dpkg -i ccurdscc_RedHawk_driver*.deb (on a Debian based system)

# cd /
# eject
```

On successful installation the source tree for the `ccurdscc` package, including the loadable kernel module, API libraries, and test programs is extracted into the `/usr/local/CCRT/drivers/ccurdscc`

directory by the rpm installation process, which will then compile and install the various software components.

The loadable kernel module is installed in the `/lib/modules/uname -r/misc` directory. Issue the command below to view the boards found by the driver:

```
# cat /proc/ccurdscc

Version          : 23.0.1
Built           : Mon Jun 4 2018, 10:25:49
Boards          : 1
  card=0: [0f:04.0] bus=15, slot=4, func=0, irq=105, msi=1, nbuf=10, hwm=0, ID=656739,
BoardInfo=0x92780202

DMA Memory: (Allocated): card number(s): 0
```

Once the package is installed, the driver needs to be loaded with one of the following commands:

```
=== as root ===
# cd /usr/local/CCRT/drivers/ccurdscc
# make load
  --- or on RedHawk 6.5 and below ---
# /sbin/service ccurdscc start
  --- or on RedHawk 7.0 and above ---
# /usr/bin/systemctl start ccurdscc
  --- or on Ubuntu RedHawk ---
# /bin/systemctl start ccurdscc
```

When the driver is loaded with the `/sbin/service` or `/usr/bin/systemctl` call, automatic calibration will commence for all the cards installed in the system and run in the background. This is also true when the system is rebooted. Issuing the 'make load' in the driver directory will *not* initiate an automatic calibration.

4.3. Software Removal

The **ccurdscc** driver is a dynamically loadable driver that can be unloaded, uninstalled and removed. Once removed, the only way to recover the driver is to re-install the **rpm** from the installation CDROM:



If any changes have been made to the driver package installed in `/usr/local/CCRT/drivers/ccurdscc` directory, they need to be backed up prior to invoking the removal; otherwise, all changes will be lost.

```
=== as root ===
# rpm -e ccurdscc (driver unloaded, uninstalled, and deleted – on an RPM based system)
  --- or ---
# dpkg -P ccurdscc (driver unloaded, uninstalled, and deleted – on a Debian based system)
```

If, for any reason, the user wishes to un-load and uninstall the driver and not remove it, they can perform the following:

```
=== as root ===
# cd /usr/local/CCRT/drivers/ccurdscc
# make unload (unload the driver from the kernel)
  --- or on RedHawk 6.5 and below ---
# /sbin/service ccurdscc stop
  --- or on RedHawk 7.0 and above ---
# /usr/bin/systemctl stop ccurdscc
  --- or on Ubuntu RedHawk ---
# /bin/systemctl stop ccurdscc
```

To uninstall the **ccurdscc** driver, do the following after it has been unloaded:

```
=== as root ===
# cd /usr/local/CCRT/drivers/ccurdscc
# make uninstall          (uninstall the driver and library)
```

In this way, the user can simply issue the **'make install'** and **'make load'** in the **/usr/local/CCRT/drivers/ccurdscc** directory later to re-install and re-load the driver.

5. Auto-loading the Driver

The **ccurdscc** driver is a dynamically loadable driver. Once you install the package or perform the **'make install'**, appropriate installation files are placed in the **/etc/rc.d/rc*.d** or **/usr/lib/systemd/systemd** directory so that the driver is automatically loaded and unloaded when Linux is booted and shutdown. If, for any reason, you do not wish to automatically load and unload the driver when Linux is booted or shutdown, you will need to manually issue the following command to enable/disable the automatic loading of the driver:

```
=== as root ===
    --- on RedHawk 6.5 and below ---
# /sbin/chkconfig --add ccurdscc          (enable auto-loading of the driver)
# /sbin/chkconfig --del ccurdscc        (disable auto-loading of the driver)
    --- or on RedHawk 7.0 and above ---
# /usr/bin/systemctl enable ccurdscc     (enable auto-loading of the driver)
# /usr/bin/systemctl disable ccurdscc    (disable auto-loading of the driver)
    --- or on Ubuntu RedHawk ---
# /bin/systemctl enable ccurdscc        (enable auto-loading of the driver)
# /bin/systemctl disable ccurdscc       (disable auto-loading of the driver)
```

6. Testing and Usage

Build and run the driver test programs, if you have not already done so:

```
# cd /usr/local/CCRT/drivers/ccurdscc
# make test          (build the test programs)
```

Several tests have been provided in the **/usr/local/CCRT/drivers/ccurdscc/test** directory and can be run to test the driver and board.

```
=== as root ===
# ./test/ccurdscc_disp          (display channel data)
# ./test/ccurdscc_dump         (dump board registers)
# ./test/ccurdscc_get_sps      (determine sample rate for the channels)
# ./test/ccurdscc_rdreg       (display board resistors)
# ./test/ccurdscc_reg         (Display board resistors)
# ./test/ccurdscc_regedit     (Interactive board register editor test)
# ./test/ccurdscc_tst        (Interactive test to test driver and board)
# ./test/ccurdscc_wreg       (edit board resistors)
# ./test/lib/ccurdscc_calibrate (library: get/set board calibration)
# ./test/lib/ccurdscc_compute_pll_clock (library: compute pll clock)
# ./test/lib/ccurdscc_disp    (library: display channel data)
# ./test/lib/ccurdscc_identify (library: identify board)
# ./test/lib/ccurdscc_fifo    (library: perform FIFO reads)
# ./test/lib/ccurdscc_tst_lib (library: Interactive test to test driver and board)
# ./test/lib/sprom/ccurdscc_sprom (library: serial prom view/update calibration utility)
```

7. Re-building the Driver, Library and Tests

If for any reason the user needs to manually rebuild and load an *installed rpm* package, they can go to the installed directory and perform the necessary build.



Warning: Before installing the software, the kernel build environment **must** be set up and match the current OS kernel you are using. If you are running one of the preconfigured kernels supplied by Concurrent Real-Time and have not previously done so, run the following commands while logged in as the root user before installing the driver software:

```
# cd /lib/modules/`uname -r`/build
# ./ccur-config -c -n
```

If you have built and are running a customized kernel configuration the kernel build environment should already have been set up when that custom kernel was built.

To build the driver and tests:

```
=== as root ===
# cd /usr/local/CCRT/drivers/ccurdsc
# make clobber      (perform cleanup)
# make              (make package and build the driver, library and tests)
(Note: if you only wish to build the driver, you can enter the 'make driver' command instead)
```

After the driver is built, you will need to install the driver. This install process should only be necessary if the driver is re-built with changes.

```
=== as root ===
# cd /usr/local/CCRT/drivers/ccurdsc
# make install      (install the driver software, library and man page)
```

Once the driver and the board are installed, you will need to **load** the driver into the running kernel prior to any access to the CCURDSCC board.

```
=== as root ===
# cd /usr/local/CCRT/drivers/ccurdsc
# make load         (load the driver)
```

8. Software Support

This driver package includes extensive software support and test programs to assist the user in communicating with the board. Refer to the *Concurrent Real-Time PCIe 32-Channel Delta Sigma Converter Card (DSCC) Software Interface* document for more information on the product.

8.1. Device Configuration

After the driver is successfully loaded, the device to card association file **ccurdsc_devs** will be created in the **/usr/local/CCRT/drivers/ccurdsc/driver** directory, if it did not exist. Additionally, there is a symbolic link to this file in the **/usr/lib/config/ccurdsc** directory as well. If the user wishes to keep the default one-to-one device to card association, no further action is required. If the device to card association needs to be changed, this file can be edited by the user to associate a particular device number with a card number that was found by the driver. The commented portion on the top of the **ccurdsc_devs** file is automatically generated every time the user issues the **'make load'**, **'/sbin/service ccurdsc start'** (on RedHawk 6.5 and below), or **'systemctl start ccurdsc'** (on RedHawk 7.0 and above) command with the current detected cards, information. Any device to card

association edited and placed in this file by the user is retained and used during the next **'make load'**, **'/sbin/service ccurdscs start'** or **'systemctl start ccurdscs'** process.

If the user deletes the **ccurdscs_devs** file and recreates it as an empty file and performs a **'make load'** or if the user does not associate any device number with card number, the driver will provide a one to one association of device number and card number. For more information on available commands, view the commented section of the **ccurdscs_devs** configuration file.



Warning: If you edit the **ccurdscs_devs** file to associate a device to a card, you will need to re-issue the **'make load'**, **'/sbin/service ccurdscs start'**, or **'systemctl start ccurdscs'** command to generate the necessary device to card association. This device to card association will be retained until the user changes or deletes the association. **If any invalid association is detected, the loading of the driver will fail.**

8.2. Library Interface

There is an extensive software library that is provided with this package. For more information on the library interface, please refer to the *PCIe 32-Channel Delta Sigma Converter Card (DSCC) Software Interface by Concurrent Real-Time* document.

8.3. Calibration

Several library calls are provided to assist the user in calibrating the board. Additionally, the board contains factory calibration information for the output voltage range. Users can view this information using the supplied API or the serial prom test utility *ccurdscs_sprom*. Though the API and test utility provides capability to edit and change the factory calibration, users should refrain from making any changes to it, as it will no longer reflect the factory calibration shipped with the card. Users can use the factory calibration to restore the calibration information stored for each configured channel prior to commencing a test run. The restore API will update the calibration information for all the channels based on their current voltage range. Note that the factory calibration values were obtained under specific conditions, such as temperature, that may not be the same as the user application. In most cases it will always be better to perform auto-calibration after the board is stabilized in the user environment.

Additionally, the users can perform up to two independent user controlled checkpoints where the active channel configuration and calibration information is stored in the serial prom for all the channels. At any time, the user can restore either of the two checkpoints with an API call or the serial prom test utility *ccurdscs_sprom* prior to a test run. These checkpoints will allow the user to store specific values pertaining to their calibration conditions.

8.4. Firmware Updates

This board is capable of being re-programmed in the field as new firmware updates are made available by *Concurrent Real-Time™*. The procedure for re-programming the firmware will be supplied to the user at the time when a firmware update is necessary.

8.5. Debugging

This driver has some debugging capability and should only be enabled while trying to trouble-shoot a problem. Once resolved, debugging should be disabled otherwise it could adversely affect the performance and behavior of the driver.

To enable debugging, the **Makefile** file in **/usr/local/CCRT/drivers/ccurdscs/driver** should be edited to un-comment the statement (*remove the preceding #*):

```
#BUILD_TYPE=debug
```

Next, compile and install the driver

```
# cd /usr/local/CCRT/drivers/ccurdsc/driver
# make
# make install
```

Next, edit the **ccurdsc_config** file in **/usr/local/CCRT/drivers/ccurdsc/driver** to un-comment the statement (remove the preceding '#'):

```
# ccurdsc_debug_mask=0x00002040
```

Additionally, the value of the debug mask can be changed to suite the problem investigated. Once the file has been edited, the user can load the driver by issuing the following:

```
# cd /usr/local/CCRT/drivers/ccurdsc/driver
# make load
```

The user can also change the debug flags after the driver is loaded by passing the above debug statement directly to the driver as follows:

```
# echo "ccurdsc_debug_mask=0x00082047" > /proc/driver/ccurdsc
```

Following are the supported flags for the debug mask as shown in the **ccurdsc_config** file.

```
#####
#
#          D_ENTER          0x00000001 /* enter routine */
#          D_EXIT           0x00000002 /* exit routine */
#
#          D_L1             0x00000004 /* level 1 */
#          D_L2             0x00000008 /* level 2 */
#          D_L3             0x00000010 /* level 3 */
#          D_L4             0x00000020 /* level 4 */
#
#          D_ERR            0x00000040 /* level error */
#          D_WAIT           0x00000080 /* level wait */
#
#          D_INT0           0x00000100 /* interrupt level 0 */
#          D_INT1           0x00000200 /* interrupt level 1 */
#          D_INT2           0x00000400 /* interrupt level 2 */
#          D_INT3           0x00000800 /* interrupt level 3 */
#          D_INTW           0x00001000 /* interrupt wakeup level */
#          D_INTE           0x00002000 /* interrupt error */
#
#          D_RUNTIME        0x00010000 /* display read times */
#          D_WTIME          0x00020000 /* display write times */
#          D_REGS           0x00040000 /* dump registers */
#          D_IOCTL          0x00080000 /* ioctl call */
#
#          D_DATA           0x00100000 /* data level */
#          D_DMA            0x00200000 /* DMA level */
#          D_DBUFF          0x00800000 /* DMA buffer allocation */
#
#          D_NEVER          0x00000000 /* never print this debug message */
#          D_ALWAYS         0xffffffff /* always print this debug message */
#          D_TEMP           D_ALWAYS /* Only use for temporary debug code */
#####
```

Another variable **ccurdsc_debug_ctrl** is also supplied in the **ccurdsc_config** that the driver developer can use to control the behavior of the driver. The user can also change the debug flags after the driver is loaded by passing the above debug statement directly to the driver as follows:

```
# echo "ccurdsc_debug_ctrl=0x00001234" > /proc/driver/ccurdsc
```

To make use of this variable, the driver must be coded to interrogate the bits in the ***ccurdscc_debug_ctrl*** variable and alter its behavior accordingly.

9. Notes and Errata

- The 9277 board comes in +/-5 Volt range.
- The 9278 board comes in +/-10 Volt range.
- Full differential mode is supported by these boards.
- When synchronizing multiple cards, only one synchronization clock can be selected even though the board supports multiple clocks.
- Driver and board supports MSI interrupts. The default configuration is to perform MS interrupts.

Appendix A: External Connections and Pin-outs

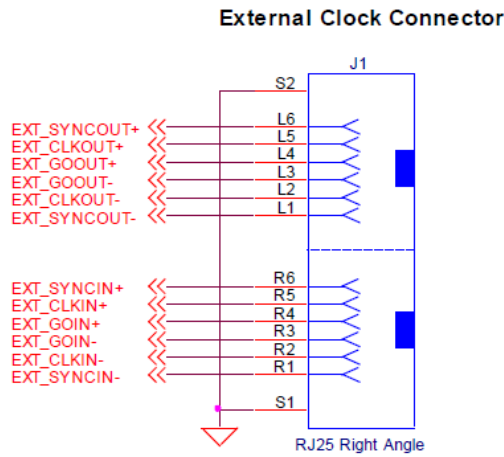
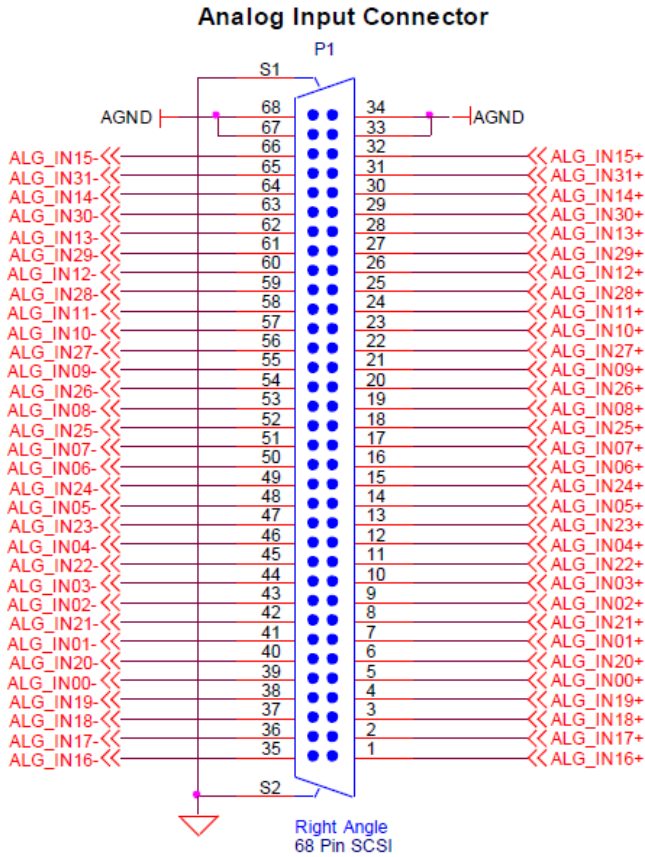

Appendix B: The 9277 (CP-AD3224-DS) +/- 5 Volt Board

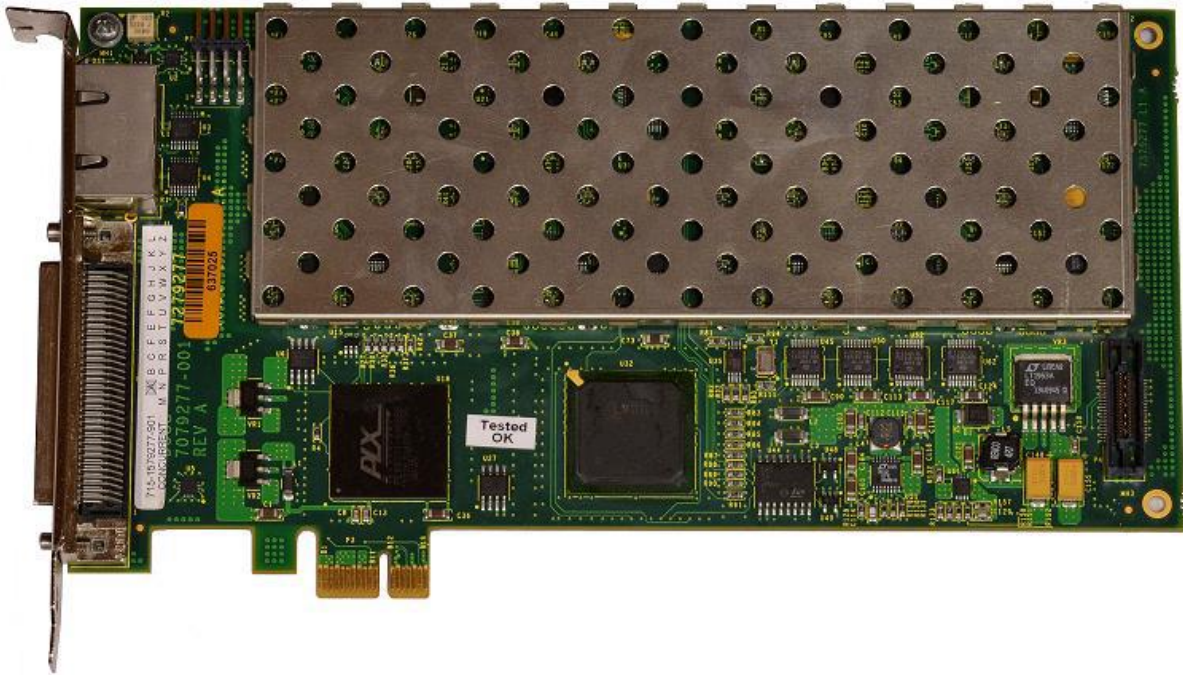

Appendix C: The 9278 (CP-AD3224-DS-10) +/- 10 Volt Board

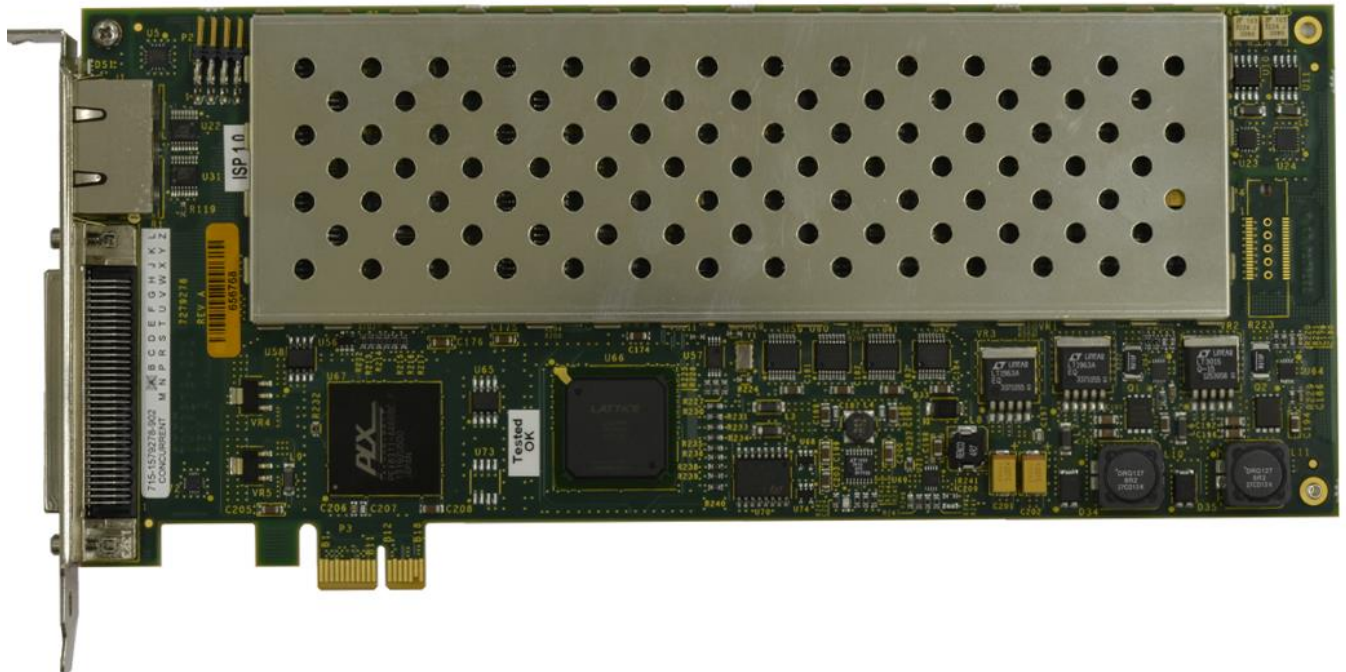

This page intentionally left blank